



## Preva Dental X-ray System



## Installation and Service Manual



00-02-1577 Rev AE  
ECN: P3785

**Attention:**

The equipment must only be installed and operated in accordance with the safety procedures and operating instructions given in this manual and in the User Manual for the purposes and applications for which it was designed. Modifications and/or additions to the equipment may only be carried out by Midmark Corp. or by third parties expressly authorized by Midmark Corp. to do so. Such changes must comply with legal requirements as well as with the generally accepted technical rules. It is the responsibility of the user to ensure that existing legal regulations regarding installation of the equipment with respect to the building are observed.

**X-RAY PROTECTION:**

X-ray equipment may cause injury if used improperly.

**The instructions contained in this manual must be read and followed when operating the Preva. Your Midmark Dental dealer will assist you in placing the Preva in operation.**

The Preva Dental X-ray System provides a high degree of protection from unnecessary radiation. However, no practical design can provide complete protection nor prevent operators from exposing themselves or others to unnecessary radiation.



Midmark Corporation  
675 Heathrow Drive  
Lincolnshire, Illinois 60069 USA  
Phone: 800-MIDMARK Fax: (847) 415-9801  
[midmark.com](http://midmark.com)



Preva Dental X-ray System  
**Installation and Service Manual**

**Midmark Corporation**

675 Heathrow Dr.  
Lincolnshire, Illinois 60069 USA  
Phone: 800-MIDMARK Fax: (847) 415-9801  
midmark.com

# Table of Contents

X-RAY PROTECTION:.....	2
<b>TABLE OF CONTENTS.....</b>	<b>1</b>
<b>GENERAL INFORMATION.....</b>	<b>1</b>
INDICATIONS FOR USE .....	1
PRODUCT DESCRIPTION .....	1
REACH AND COVERAGE.....	4
ENVIRONMENTAL FACTORS.....	9
SUPPORT REQUIREMENTS .....	9
ELECTRICAL REQUIREMENTS.....	9
COMPLIANCE WITH APPLICABLE STANDARDS.....	10
CERTIFIED COMPONENTS .....	10
AUTHORIZED REPRESENTATIVES.....	10
SAFETY .....	11
EXPLANATION OF SYMBOLS ON TECHNICAL LABELS.....	12
OBTAINING TECHNICAL SUPPORT.....	12
<b>INSTALLATION OPTIONS.....</b>	<b>13</b>
MOUNTING CONFIGURATIONS .....	13
OPERATOR PANEL LOCATIONS.....	18
<b>INSTALLATION PROCEDURES.....</b>	<b>19</b>
PREPARING TO INSTALL THE PREVA .....	19
INSTALLING THE CONTROL UNIT ON A SINGLE WOOD STUD WALL .....	21
INSTALLING THE CONTROL UNIT ON A DUAL WOOD STUD WALL .....	26
INSTALLING THE CONTROL UNIT ON A METAL STUD WALL.....	28
INSTALLING THE HORIZONTAL ARM AND BRAKE ASSEMBLY .....	30
INSTALLING THE ARTICULATING ARM AND TUBEHEAD ASSEMBLY .....	32
CONNECTING THE CABLES .....	34
ELECTRICAL VERIFICATION .....	40
MECHANICAL ADJUSTMENTS .....	43
INSTALLING THE CONTROL UNIT FRONT COVER AND THE OPERATOR PANEL .....	44
INSTALLING PLASTIC COVERS.....	48
<b>PREVA OPERATOR PANEL.....</b>	<b>49</b>
USING THE OPERATOR PANEL .....	49
<b>CHECKING SYSTEM FUNCTIONS.....</b>	<b>50</b>
SYSTEM FUNCTION CHECKLIST.....	51
TUBE SEASONING PROCEDURE .....	52
<b>OPTIONAL INSTALLATION PROCEDURES.....</b>	<b>53</b>
INSTALLING THE COIL-CORD HAND SWITCH OPTION (30-A2040) .....	53
INSTALLING THE REMOTE EXPOSURE STATION (30-A2044) .....	55
CONNECTING TO A GENERIC 2 WIRE REMOTE EXPOSURE SWITCH .....	60

INSTALLING THE 12 INCH [30 CM] CONE (30-A2200) .....	60
<b>SYSTEM CONFIGURATION .....</b>	<b>61</b>
SYSTEM CONFIGURATION MODE .....	61
ADJUSTING THE DISPLAY .....	62
CHANGING PRE-PROGRAMMED EXPOSURE SETTINGS.....	63
SHOWING CURRENT SYSTEM CONFIGURATION .....	64
CHANGING THE CONE SIZE .....	65
DIAGNOSTIC MODE.....	66
<b>CALIBRATION .....</b>	<b>67</b>
<b>TROUBLESHOOTING .....</b>	<b>68</b>
ELECTRICAL PERFORMANCE ISSUES.....	68
OBTAINING TECHNICAL SUPPORT .....	88
<b>MAINTENANCE .....</b>	<b>89</b>
PREVA TUBEHEAD REMOVAL INSTRUCTIONS .....	89
<b>PREPROGRAMMED EXPOSURE TIMES .....</b>	<b>105</b>
ARM AND TUBEHEAD .....	106
HORIZONTAL ARM .....	107
MOUNTING PLATES .....	108
OPERATOR PANEL.....	109
CONTROL UNIT .....	110
HANDSWITCH .....	111
<b>SPECIFICATIONS .....</b>	<b>112</b>
PREVA DENTAL X-RAY SYSTEM .....	112
<b>APPENDIX A .....</b>	<b>115</b>
ASSEMBLY INSTRUCTIONS FOR DC MOBILE UNIT .....	115
REPLACING THE POWER CORD.....	125
<b>APPENDIX B .....</b>	<b>128</b>
ELECTRONICS BLOCK DIAGRAM .....	128

## General Information

**Indications for Use** The Preva Dental X-ray is to be used as an extraoral source of X-ray in Dental radiography.

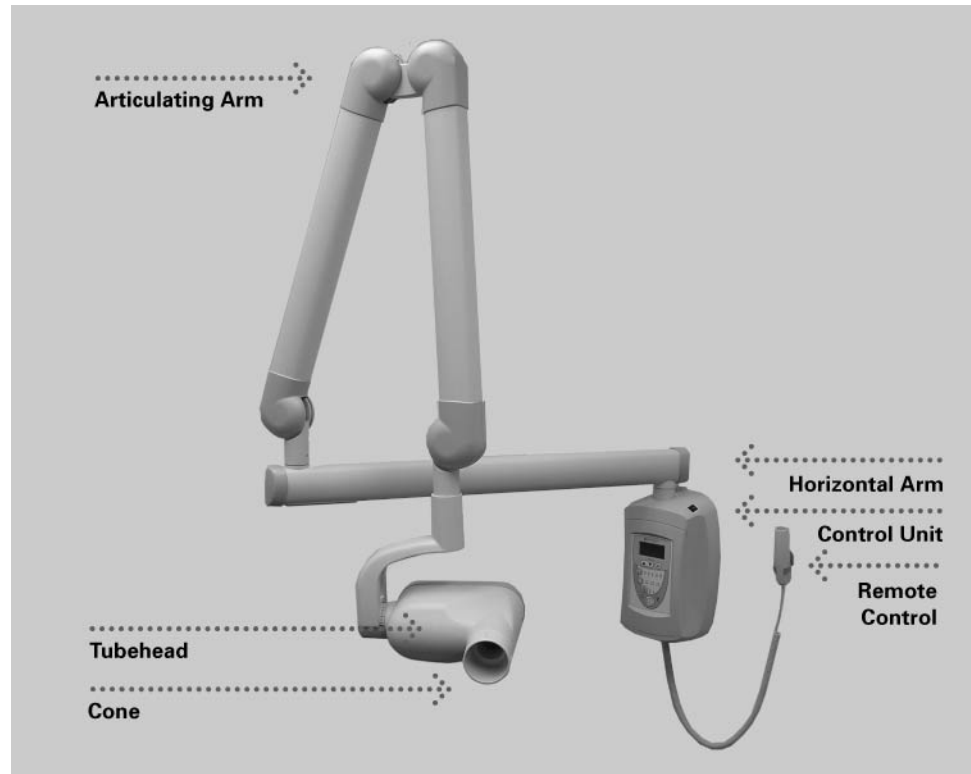
## Product Description

	<p>The Preva Dental X-ray System is a state-of-the-art, high-frequency intra-oral X-ray machine. The Preva consists of five components, as shown in Figure 1 Component Diagram: the Control Unit, the Tubehead, the Articulating Arm, the Horizontal Arm, the Cone, and the Remote Control option.</p>
<b>Control Unit</b>	<p>The Control Unit provides for the input power connection and control of the Tubehead and Operator Panel. It provides automatic line voltage compensation, kVp control, and exposure time control. The Control Unit consists of the mounting base and Operator Panel.</p>
<b>Tubehead</b>	<p>The Tubehead contains the X-ray tube, high voltage circuit, and Cone. It is shipped already assembled to the Articulating Arm.</p> <div style="border: 1px solid black; padding: 5px;"><p><b>Warning:</b> <i>There is a small hole in the plastic handle covering the back of the Tubehead. Under no circumstances should this hole be blocked as it provides an air vent to allow the Tubehead oil to expand and contract as the unit is operated.</i></p></div>
<b>Articulating Arm</b>	<p>The Articulating Arm provides the articulation support for the Tubehead and the reach and coverage of the Tubehead to the patient.</p>
<b>Horizontal Arm</b>	<p>The Horizontal Arm helps provide the necessary reach for the VetPro® DC. It pivots around a shaft inserted in the top of the Control Unit and contains an access cover to connect the cable from the Horizontal Arm to the Control Unit. It is available in four lengths on wall mount units providing reaches of 56, 66, 76 and 82 inches [142, 167, 193, 208 cm].</p>
<b>Modular Beam Limiting Device [BLD]</b>	<p>The cone establishes the distance from the X-ray tube to the patient's skin. It provides positioning assistance and collimates the X-ray beam.</p>
<b>Remote Control</b>	<p>The remote control switch is used to make exposures in addition to or replacing the use of the exposure button.</p>
<b>Model Configurations</b>	<p>The Preva is available as both a wall mount and mobile unit. See Appendix A for the installation instructions for the mobile unit.</p>
<b>Installation and Service</b>	<p>The Preva Dental X-ray System should only be installed and serviced by approved Midmark dealer personnel. Contact Midmark Corporation at 800-MIDMARK if you need assistance locating an approved dealer.</p>
<b>CAUTIONS</b>	<p>When using lag screws as the method of attachment, it is imperative to consider the full scope of the task. Several factors must be considered for safe,</p>

permanent installations. Some of the key issues are:

- Lumber commonly used in construction projects can be different from location to location.
- The grade, age, position, and overall condition can vary greatly.
- The attachment stud may have additional, hidden loads.
- The location of the pilot hole with respect to the center of the stud will affect the load bearing ability.
- The size of the pilot hole required for the lag screw will be different based on the grade, age and condition of the lumber.
- Never over-tighten the lag screw as this will weaken the mechanical connection.
- Lumber with splits or cracks should not be used for attachment.
- Plywood, particle board, or similar construction materials, should not be used for attachment.
- Consider lumber dryness or moisture when attaching to exterior framing studs.
- Midmark mechanical designs will exert up to 920 ft lbs [127 Kg m] of loading moment on the supporting structure.
- Midmark provides fasteners for average installations. Based on specific installation conditions, it may be necessary to choose an alternate fastener or fastening methods.
- If the surface of the Installation Guide falls below the surface of the wall, a correspondingly longer fastener must be chosen.
- Seek the advice of a professional structural engineer to clarify any issues before the installation.
- Inspect the attachment method 30 days after the installation and, every 6 months thereafter.
- Lag screws are not intended to be used as an attachment method for metal supports such as those found in center island pass-through cabinets. Midmark provides machine screws, large flat washers and nylock nuts to use when fastening the system to metal supports.





**Figure 1  
Component  
Diagram**

### **Your Responsibilities As An Installer And Service Engineer**

***Verification of machine performance after installation*** must be performed according to the guidelines identified in the “System Function Checklist” which may be found in the User Manual or, the Installation and Service Manual on page 51.

***Verification of machine performance after maintenance or repair*** must be performed according to the guidelines identified in the “System Function Checklist” and the calibration instructions which may be found in the Installation and Service Manual on page 51.

## Reach and Coverage

### Horizontal Arm Lengths

The reach of the system is measured from the tip of the Cone with the arm fully extended and the Cone pointing back toward the pivot of the wall plate. This measurement method accommodates the normal positioning of the Tubehead to the patient. A patient can, therefore, be positioned without difficulty with the dental chair located within a radius outward from the pivot point to the dimensions shown in the diagrams.

The Preva Horizontal Arm is available in four lengths. Each length gives the system a different reach. Catalog P7015-P with a 30-A2074 Horizontal Arm has a reach of 56 inches. Catalog P7016-P with a 30-A2073 Horizontal Arm has a reach of 66 inches. Catalog P7017-P with a 30-A2071 Horizontal Arm has a reach of 76 inches. Catalog P7018-P with a 30-A2164 Horizontal Arm has a reach of 82 inches. The diagrams show Catalog P7018-P with an 82-inch reach. For Catalog P7017-P with a 76 inch reach, reduce the dimensions by 8 inches. For Catalog P7016-P with a 66 inch reach, reduce the dimensions by 18 inches. For Catalog P7015-P, reduce the dimensions by 28 inches.

### Optional 12 Inch [30 cm] Cone

The 82-inch reach for Catalog P7018-P assumes the use of the 8 inch [20 cm] Cone that is supplied with the system. If the optional 12 inch [30 cm] Cone (30-A2200) is used, the reach is reduced by 4 inches.

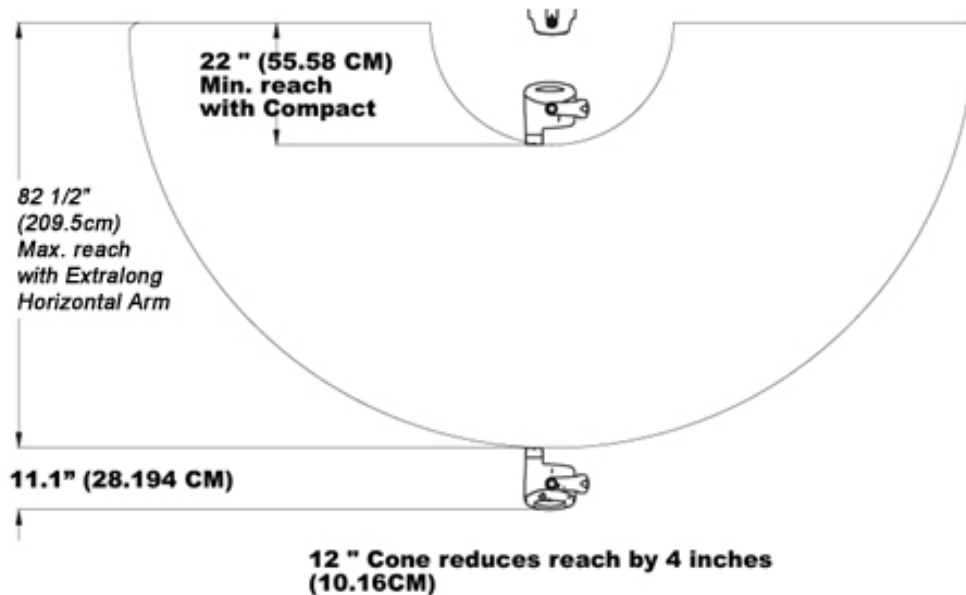


Figure 2  
Reach and Coverage Diagram

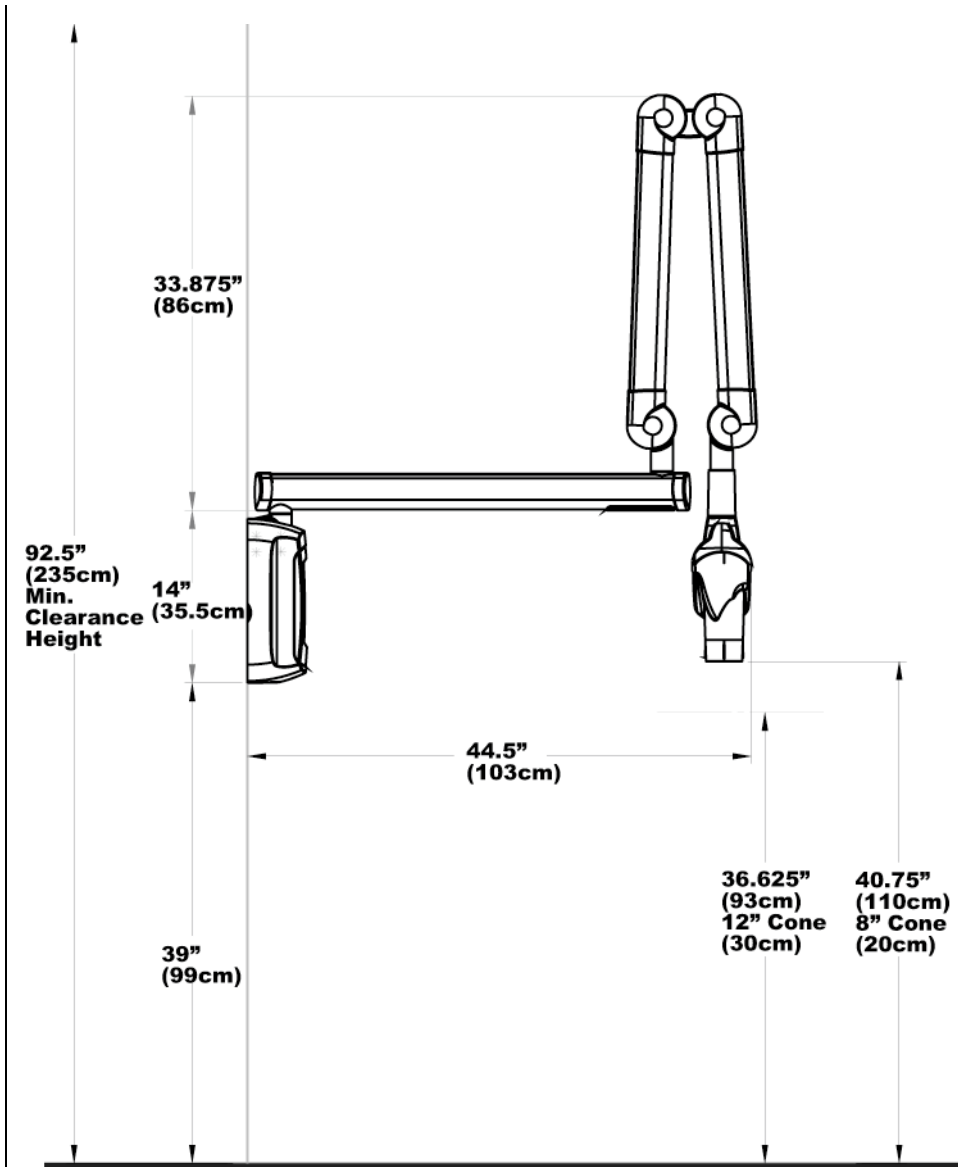
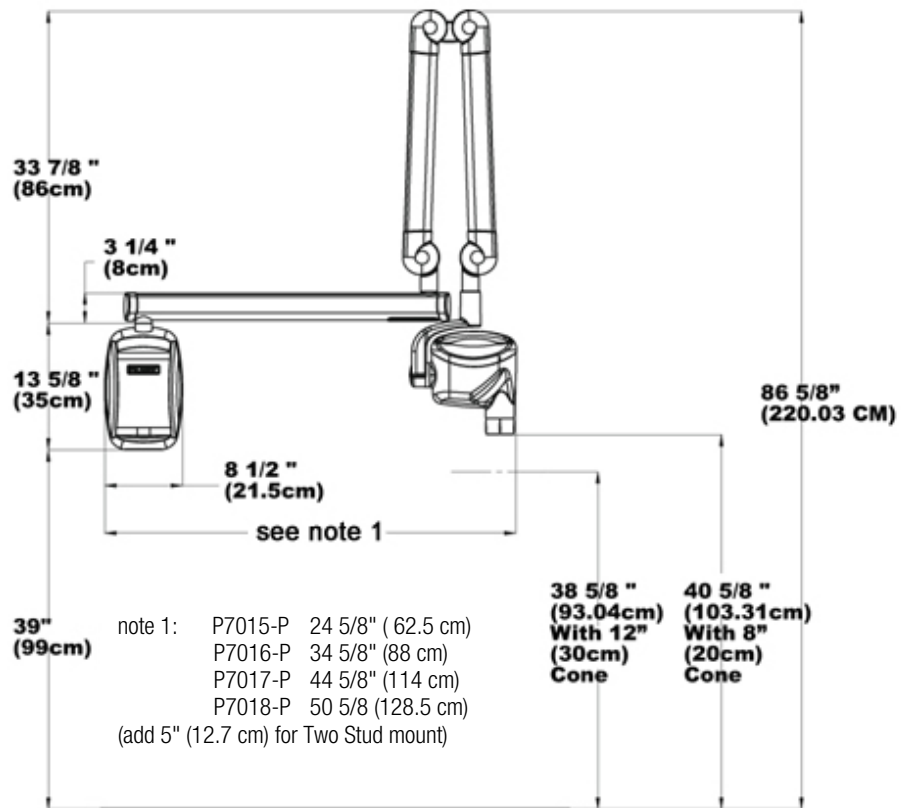
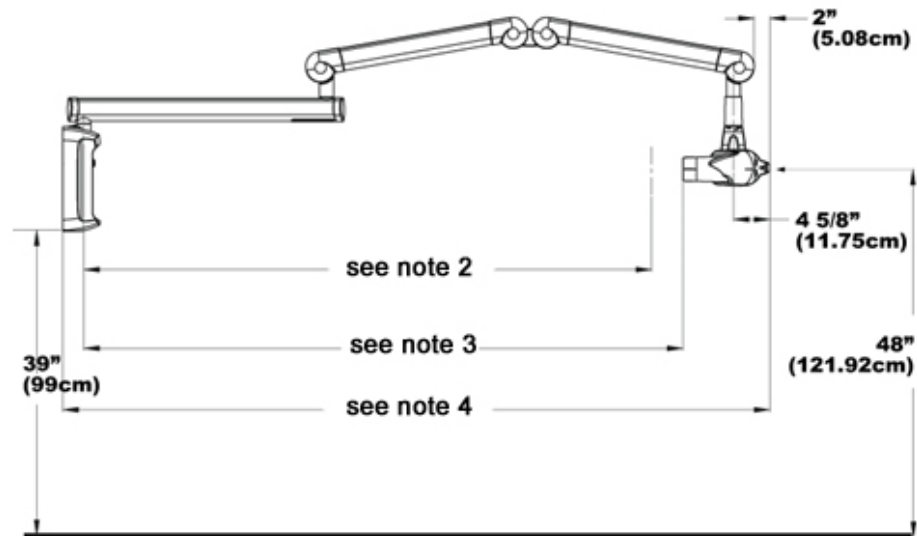


Figure 3  
Cabinet  
Mounting  
Dimensions

**82" reach not recommended for cabinet mount**



**Figure 4**  
**Retracted**  
**Wall Mount**



**Figure 5**  
**Extended**  
**Position**  
**Wall or**  
**Cabinet**  
**Mount**

note 2: **With 12" (30cm) cone**  
 P7015-P 52 1/2" (133 cm)  
 P7016-P 62 1/2" (159 cm)  
 P7017-P 72 1/2" (184 cm)  
 P7018-P 78 1/2" (199 cm)

note 3: **With 8" (20cm) cone**  
 P7015-P 56 1/2" (143.5 cm)  
 P7016-P 66 1/2" (169 cm)  
 P7017-P 76 1/2" (194.5 cm)  
 P7018-P 82 1/2" (209.5 cm)

note 4: **To handle**  
 P7015-P 70 3/8" (178.5 cm)  
 P7016-P 80 3/8" (204 cm)  
 P7017-P 90 3/8" (229.5 cm)  
 P7018-P 96 3/8" (244.5 cm)  
 (add 1" (2.5 cm) for Two Stud mount)

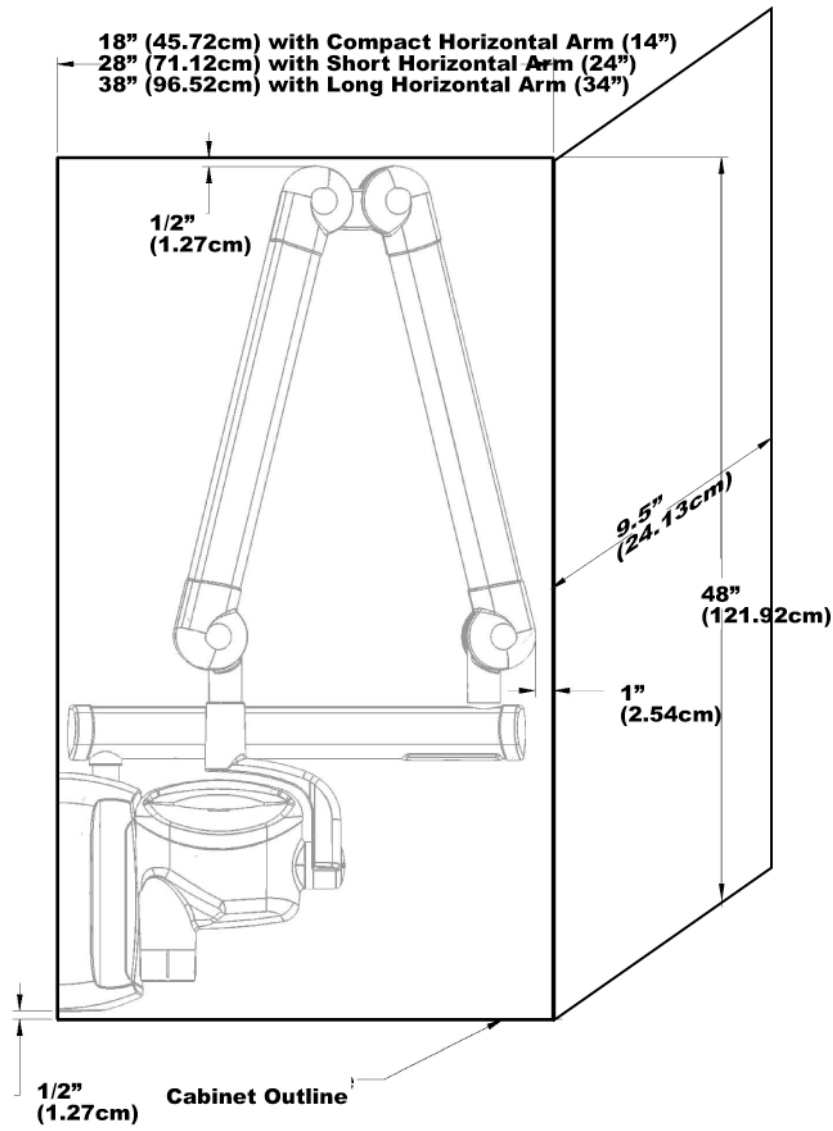
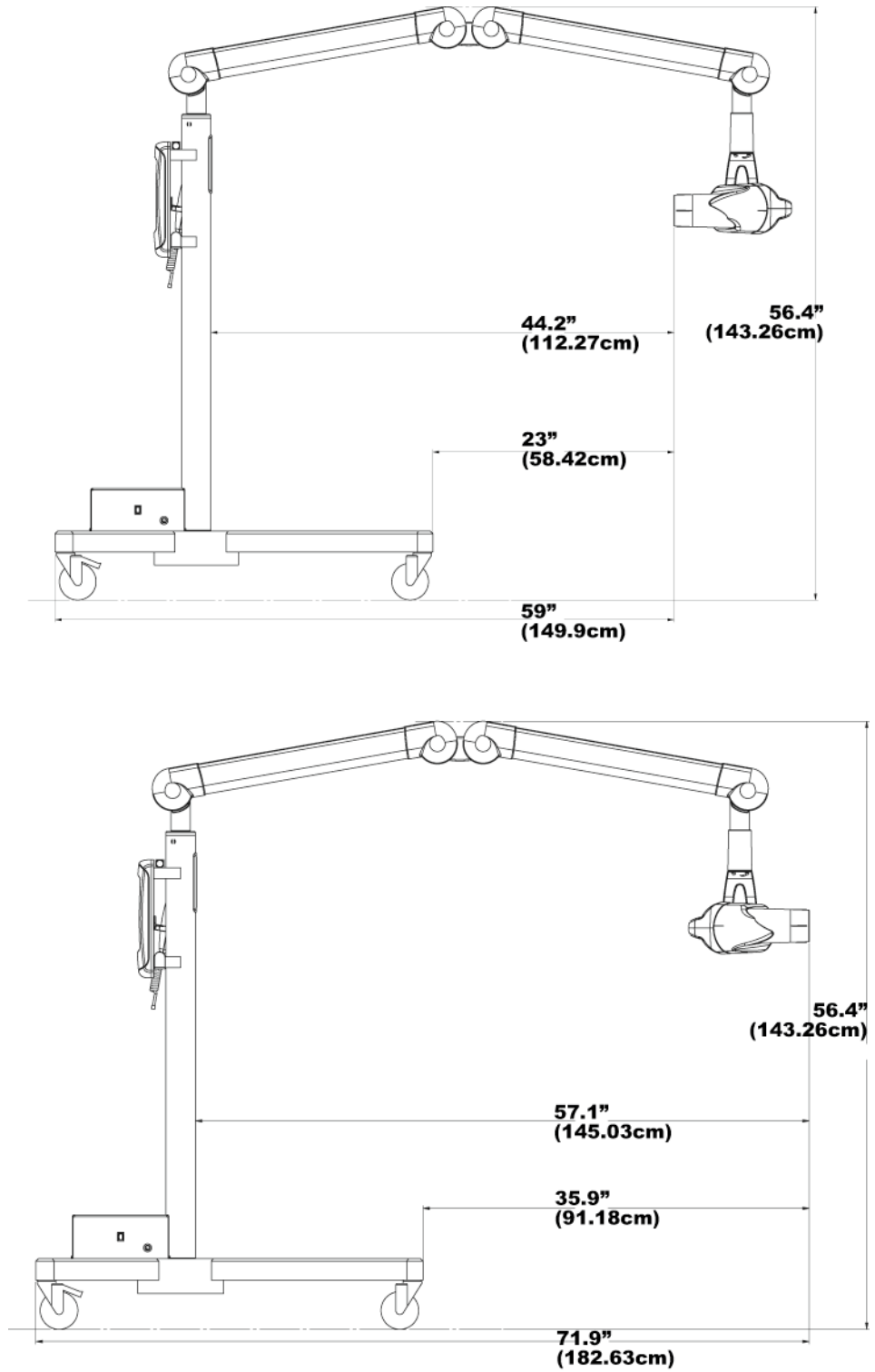


Figure 6  
Retracted  
Position for  
a Cabinet  
Mount



**Figure 7**  
**Mobile Unit**  
**Extended**

## Environmental Factors

Use	The Preva Dental X-ray System is intended for indoor use for normal dental applications at temperatures in the range +50 F / +95 F [+10 / + 35 C] and at a maximum altitude of 12,000 ft [3657 m]. Humidity should not cause condensation to form on the unit.
Storage	Storage temperature should not exceed the range -31 F / + 150 F [-35 C / + 66 C].

## Support Requirements

The Preva Dental X-ray System is designed to mount on a single wood 2x4-inch drywall stud or equivalent wall support. It can also be mounted on concrete or other similar wall construction. **Mounting to a plywood or particle board wall is not acceptable.** Verifying the wall support capability and the selection of the proper mounting hardware is the responsibility of the installer.

Please note that a two-stud wall plate assembly (30-A2042) is available to mount on two wooden studs. A metal stud mounting kit (30-A2043) is also available.

The wall support and mounting hardware for the Preva must withstand a 100 lb. [45.4 kg] shear load and a 500 lb. [227 kg] withdrawal force at each of the mounting bolts. The wall fabrication and attachments to the building structure must be capable of withstanding a load moment of 920 ft lbs [127 Kg m].

## Electrical Requirements

Mains Power Supply	The Preva Dental X-ray System requires a 3-wire single phase AC power mains that contain line conductor, neutral conductor, and protective earth conductor. It is recommended that the unit be installed with a dedicated electrical line connected to a breaker with a minimum 15 amp rating. The wiring must provide for a permanently grounded power line configuration.
Line Cord Use	The installer must determine the suitability of installing the Preva with a line cord. If a line cord is used, the installer must ensure that the unit is properly grounded and has the required line rating.
Line Voltage	AC 100 V to 250 V, 50 Hz or 60 Hz (See complete specifications on page 112)
Fuse Rating	5 A, 250 V, UL Recognized (See complete specifications on page 112)
Max Line Resistance	For normal function of the Preva Dental X-ray System the resistance of the power line should not exceed 0.4 $\Omega$ at nominal line voltage.

## Compliance with Applicable Standards

<b>Radiation Protection</b>	<p>The certified components of the Preva Dental X-ray System comply with Radiation Performance Standards 21 CFR, Subchapter J, at the time of manufacture.</p> <p>The certified components of the Preva Dental X-ray System comply with IEC 60601-1-3 Radiation protection/X-ray equipment.</p>
<b>UL 2601-1 File Number: E181750</b>	Classified by Underwriters Laboratories Inc. with respect to electrical shock, fire and mechanical hazards only in accordance with UL 2601-1, and CAN/CSA C22.2 NO, 601.1-M90, and to the following particular standards, IEC60601-2-7, IEC60601-2-28.
<b>EMI/EMC</b>	IEC60601-1-2

## Certified Components

System	Component	Reference Number
	Tubehead	30-A1027
	Control Unit. Preva Mobile	30-A0013
	Control Unit. Preva	30-A0010
	Modular BLD, 20 cm Lg., 70 mm Cone, Gray	30-A2195
	Modular BLD, 30 cm Lg., 70 mm Cone, Gray	30-A2200
	Modular BLD, 20 cm Lg., 60 mm Cone, White	30-A2196
	Modular BLD, 30 cm Lg., 60 mm Cone, White	30-A2201
	Modular BLD, 30 cm Lg., 60 mm Cone, Gray	30-A2229
	Modular BLD, 20 cm Lg., 30x40 mm Cone, White	30-A2198
	Modular BLD, 30 cm Lg., 30x40 mm Cone, White	30-A2203
	Modular BLD, 20 cm Lg., 20x30 mm Cone, White	30-A2199
	Modular BLD, 20 cm Lg., 35x45 mm Cone, Gray	30-A2221
	Modular BLD, 20 cm Lg., 35x45 mm Cone, White	30-A2222
	Modular BLD, 30 cm Lg., 35x45 mm Cone, Gray	30-A2223
	Modular BLD, 30 cm Lg., 35x45 mm Cone, White	30-A2224
	Modular BLD, Base, Gray	30-A2205
	Modular BLD, Spacer, Gray	30-A2206
	Modular BLD, Spacer, White	30-A2208

## Authorized Representatives

<b>North America</b>	<p>Midmark Corporation 675 Heathrow Dr. Lincolnshire, Illinois 60069 U.S.A. Phone: 800-MIDMARK Fax: 847-415-9801</p>
----------------------	--



## Europe

CE Partner 4U  
Esdoornlaan 13  
3951DB Maarn  
The Netherlands  
[www.cepartner4u.eu](http://www.cepartner4u.eu)

## Safety

### Radiation Safety

- Only qualified and authorized personnel may operate this equipment observing all laws and regulations concerning radiation protection.
- The operator at all times must remain at a safe distance from the focal spot and the X-ray beam for operator protection.
- Full use must be made of all radiation safety features on the equipment.
- Full use must be made of all radiation protection devices, accessories and procedures available to protect the patient and operator from X-ray radiation.






### Electrical Safety

- **WARNING: To avoid the risk of electric shock, this equipment must only be connected to supply mains with protective earth.**
- Only qualified and authorized service personnel should remove covers on the equipment.
- All maintenance that requires removing of protective covers must be executed by service personnel when the patient is not present.
- The sensor shall only be replaced when the operator and any part of the machine does not touch the patient. **Caution:** Operator is not to touch the *USB connector on the Articulated Arm.*
- This equipment must only be used in rooms or areas that comply with all applicable laws and recommendations concerning electrical safety in rooms used for medical purposes, e.g., IEC, US National Electrical code, or VDE standards concerning provisions of an additional protective earth (ground) terminal for power supply connection.
- Before cleaning or disinfecting, this equipment must always be disconnected from the main electrical supply.
- The Preva Dental X-ray is ordinary type medical equipment without protection against ingress of liquids. To protect against short-circuit and corrosion, no water or any other liquid should be allowed to leak inside the equipment.

### Explosion Safety

This equipment must not be used in the presence of flammable or potentially explosive gases or vapors, which could ignite, causing personal injury and/or damage to the equipment. If such disinfectants are used, the vapor must be allowed to disperse before using the equipment.

## Explanation of Symbols on Technical Labels

	Type B: Protection against electric shock (IEC 60601.1-1)
	Consult written instructions in User's Manual.
	WARNING X-RAY THIS X-RAY UNIT MAY BE DANGEROUS TO PATIENT AND OPERATOR UNLESS SAFE EXPOSURE FACTORS AND OPERATING INSTRUCTIONS ARE OBSERVED.
	<i>X-RAY EMISSION</i>
<b>L</b>	Mains HOT WIRE
<b>N</b>	Mains NEUTRAL WIRE
	Earth Ground

## Obtaining Technical Support

Contact	Midmark Corporation 675 Heathrow Dr. Lincolnshire, IL 60069 Phone: 800-MIDMARK Fax: 847-415-9801 imagingtechsupport@midmark.com
---------	--

# Installation Options

## Mounting Configurations

### Mounting Template

This section gives instructions for installing the Preva Dental X-ray System in three mounting configurations. Use the mounting template, shown in *Figure 8*, to guide single stud installations. Reverse the template for dual-stud installations.

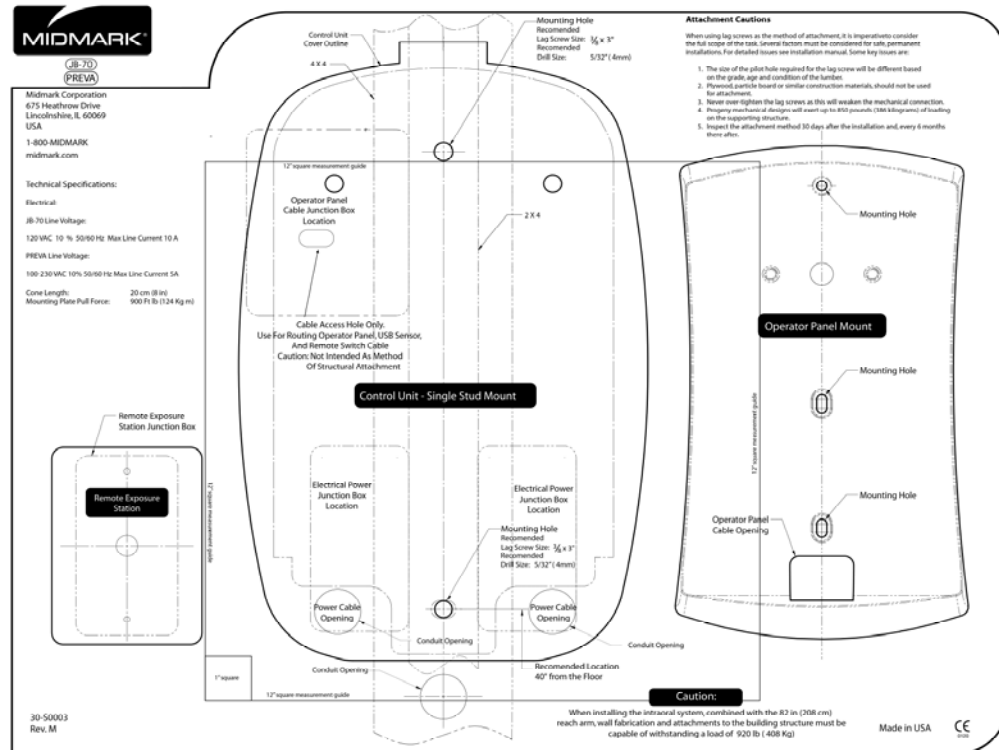


Figure 8  
Mounting  
Template

**CAUTION:**  
When installing the intraoral system, combined with the 82 inch [209 centimeter] reach arm, wall fabrication and attachments to the building structure must be capable of withstanding a load moment of 920 ft lbs [127 Kg m].

**CAUTION:**  
Lag screws are not intended to be used as an attachment method for metal supports such as those found in center island pass-through cabinets. Midmark provides machine screws, large flat washers and nylock nuts to use when fastening the system to metal supports.

**Single  
Wood Stud  
Wall, Solid  
Wall, or  
Reinforced  
Wood  
Cabinet**

The Control Unit should be located at a height of 39 inches [99 cm] from the floor to the bottom of the control, mounted on the wood stud, as shown in *Figure 9*. The large range of travel of the Articulating Arm provides some flexibility in the vertical position. Two mounting holes are provided. Refer to the supplied mounting template, shown in *Figure 8*, for specific locations.

In order to mount to a solid, masonry type wall, the same mounting holes and mounting template as the single wood wall stud are used. The installer must supply appropriate fasteners.

The power supply 2x4 junction box should be mounted to the left of the mounting stud at the appropriate height, as indicated in the mounting template.

**Note:** A 4x4 junction box will not be covered by the Control Unit. Refer to the supplied mounting template for specific location.

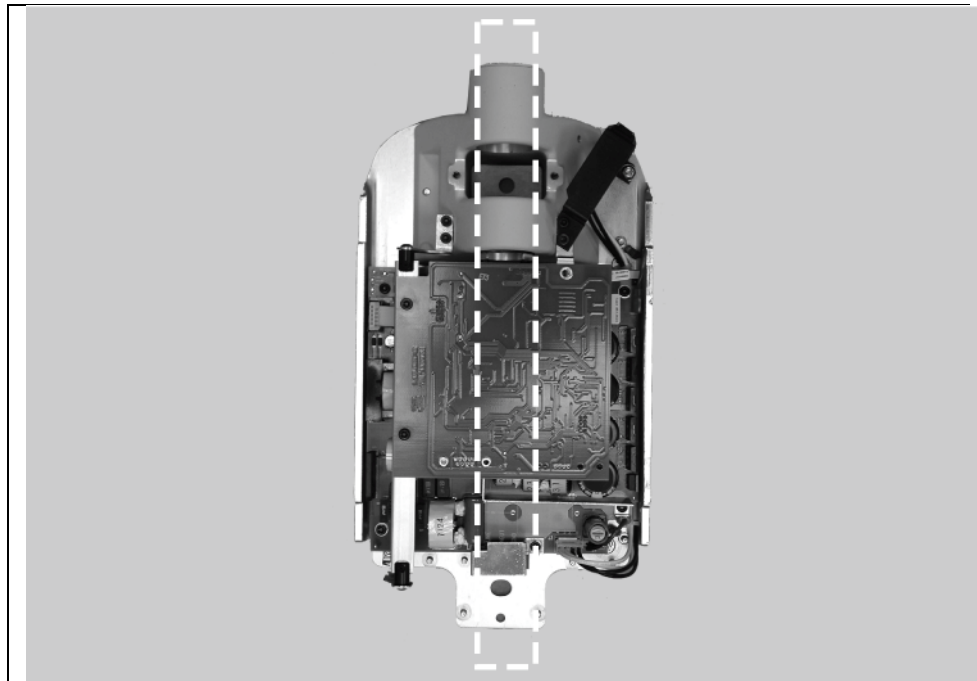


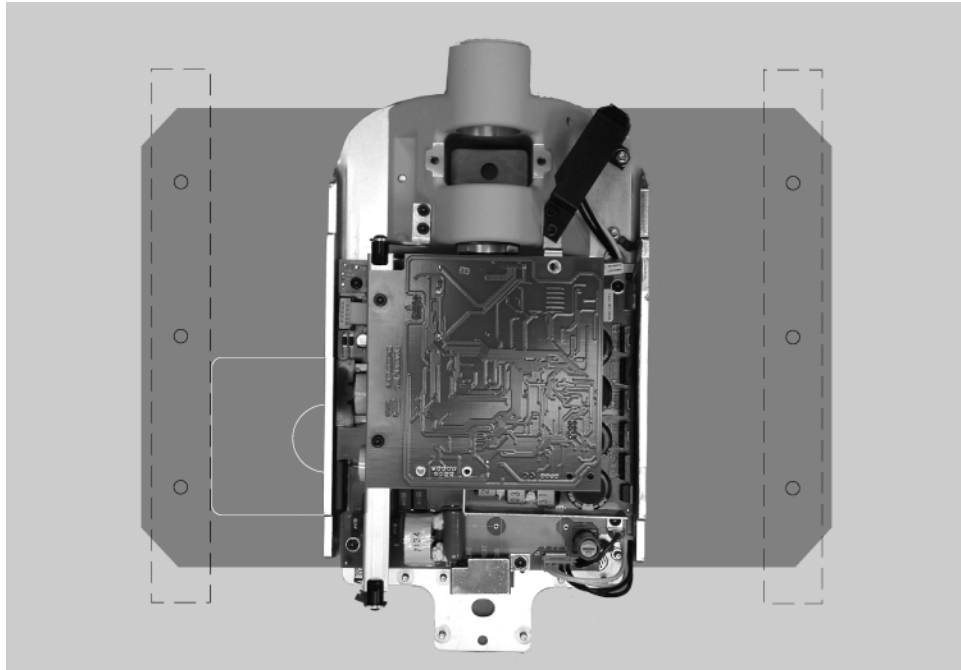
Figure 9  
Wood Wall  
Stud Mount

**WARNING:**  
**UNDER NO CIRCUMSTANCES SHOULD THE 82 INCH [20 CM] REACH SYSTEM BE ATTACHED TO A WALL IN THE SINGLE STUD CONFIGURATION. PLEASE DIRECT ANY QUESTIONS ON THIS MATTER TO MIDMARK TECHNICAL SUPPORT.**

### Dual Wood Stud Wall

When installing the Preva Dental X-ray System on two 16-inch [40 cm] centered wood studs, the Control Unit is mounted to a wall plate (Two Stud Mounting Kit 30-A2042), which mounts to the wood studs, as shown in *Figure 10*. Fasteners are provided with the wall plate.

In mounting configurations using the dual stud wall plate, there are several holes available for incoming line power. This is to provide for various locations of existing power boxes when installing as a replacement unit. Refer to the reverse side of the mounting template, *Figure 8*, for hole locations.

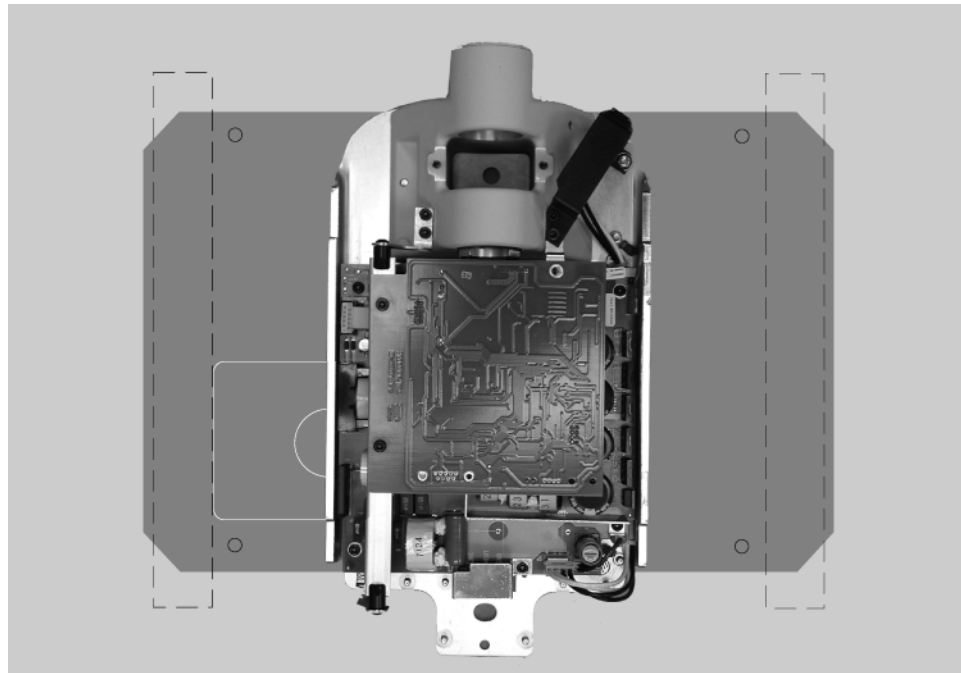


**Figure 10**  
**Dual Wood**  
**Stud Mount**

### **Metal Stud Wall**

When installing the Preva Dental X-ray System on a metal stud wall, the Control Unit is mounted to a wall plate (Two Stud Mounting Kit 30-A2042) and uses an additional support plate (Metal Stud Support Plate Kit 30-A2043, purchased as an option) positioned on the back end of the wall. See *Figure 11*. Fasteners are provided with the wall plate and support plate. The wall fabrication and attachments to the building structure must be capable of withstanding a load moment of 850 ft. lbs. [118 m·kg]. If the wall on which the Preva is to be installed does not meet this requirement, it must be reinforced.

In mounting configurations using the dual stud wall plate, there are several holes available for incoming line power. This is to provide for various locations of existing power boxes when installing as a replacement unit. Refer to the mounting template in *Figure 8* for hole locations.



**Figure 11  
Metal Stud  
Mount**

### Installing the 4x4 Mount

The 4x4 Mount kit (30-A2099), shown in Figure 12, contains the items below:

- Power line bracket
- Power cord cover
- Left conduit mounting plate
- Right conduit mounting plate
- 3 Phillips screws
- 6 nuts

### Instructions

1. Using the three Phillips screws, secure the power line bracket to the power line cord cover.
2. Place the right and left conduit mounting plates on the control.
3. Place the assembled power line bracket and cord cover on the two bottom-most threaded studs.

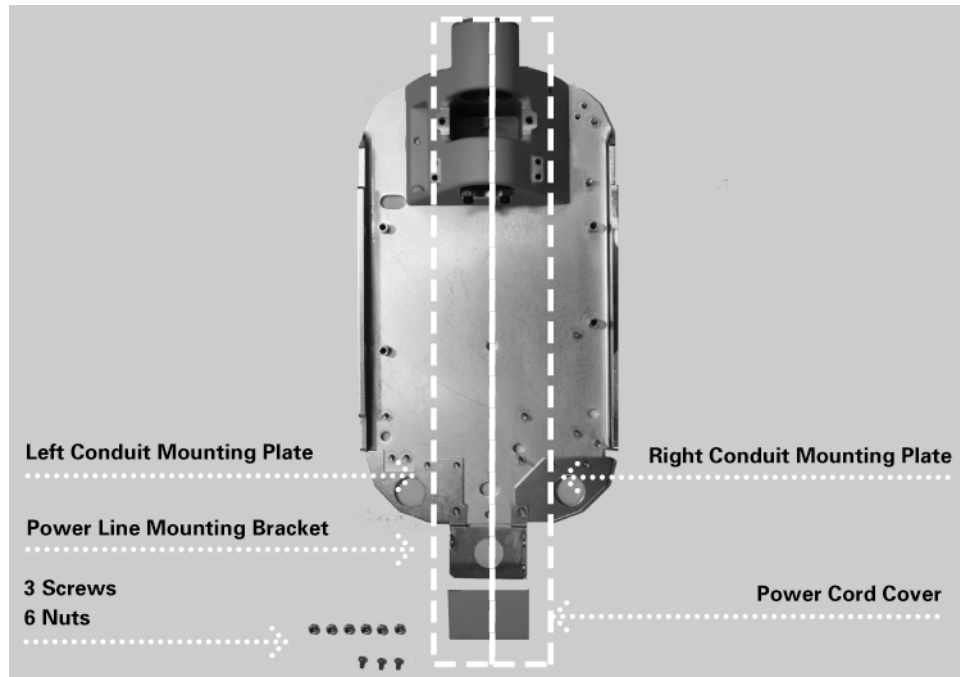


Figure 12  
4x4 Mount  
Cabinet  
Layout

## Operator Panel Locations

### On Control Unit

The Operator Panel for the Preva Dental X-ray System can be installed on the Control Unit or mounted remotely on a wall.

The Operator Panel snaps on to the front of the Control Unit. Installation of the Operator Panel on the Control Unit may require the purchase and use of the coil-cord hand switch option, 30-A2040.

### Remote Operator Panel

The Operator Panel is mounted on the wall remote from the Control Unit.

If the Operator Panel is mounted separate from the Control Unit, a supplied cable must be run from the Control Panel to the Operator Panel. Where local codes require, a separate 2x4 junction box should be mounted to the left of the mounting stud above the power supply box. Refer to the supplied mounting template for specific location.



## Installation Procedures

### Preparing to Install the Preva

#### Check Pre-installation Requirements

Prior to beginning the installation, be sure that all pre-installation requirements have been completed. This includes confirming that the wall support requirements are adequate for mounting the unit and that the electrical power requirements and wire locations are proper.

**Note:** Midmark recommends that the Preva Dental X-ray System be connected to dedicated wiring and permanently grounded. The installer must determine the suitability of using a line cord at the time of installation, ensuring proper grounding technique.

#### Gather Tools

Items needed for all types of mounts:

- Stud finder
- Bubble level (torpedo level)
- Masking or other tape for placing the mounting template on the wall
- Awl
- Drill driver and drill bits appropriate to type of wall mounting
- Metric Allen wrench set
- English (inch) Allen wrench set
- Screwdrivers (flat-blade and Phillips)
- Torque wrench 0-40 ft-lbs. [0-5.53 m-kgs] or equivalent
- Sockets and ratchet driver appropriate to type of wall mounting
- Fluke model 73 DVM equivalent or better
- Small test clips (such as Pomona Electronics Minigrabber Test Clip Model 6248 or Radio Shack Mini-Hook Adapters catalog # 270-334)

Items needed only for the metal stud wall mount:

- 1-inch hole saw
- Dry wall saw
- 1/4-inch diameter 12-inch long drill bit
- Two 4x4 wood studs
- Drywall screws

#### Installation Time

The Preva Dental X-ray System has been designed to be installed by one person in less than one hour, assuming that all pre-installation requirements have been met.

#### Open the Shipping Carton

The Preva Dental X-ray System is shipped in a convenient two-level carton, as shown in *Figure 13*. The first level contains the items needed for the first part of the installation, including the Control Unit, Operator Panel, Horizontal Arm, mounting template, documentation, cables, and packets containing the mounting hardware, brake assembly plastic covers, and additional hardware. The Articulating Arm and Tubehead Assembly are in the second level of the shipping carton, where they can remain until installation.



**Figure 13**  
**Two-level Carton**

**Packing List**

<b>Part Number</b>	<b>Description</b>	<b>Quantity</b>
30-A1028	Articulating Arm and Tubehead Assembly	1
30-A1025	Control Unit Assembly	1
30-A2076	Operator Panel	1
30-P0029	Operator Panel Mounting Cradle	1
30-A2046	Preva Mounting Hardware Kit	1
30-A2156	Preva Plastic Covers / Brake Kit	1
30-A2077	Two Stud Mount Assembly (Optional)	1
30-A2040	Handswitch Assembly (Optional)	1
E1-13052	Line Cord, 16/3 6' Wide	1
30-A2195	Modular BLD, 70 mm Cone	1
30-A2221	Modular BLD, 35 x 45 Cone	1
E1-13004	Cable, 8 Cond. 0.5 ft.	1
E1-13003	Cable, 8 Cond. 25 ft.	1
30-A2218	Preva Documentation Kit	1

**Note: Shipment Contains One of the Following Extension Arms Per Order**

30-A2071	Extension Arm, Long	1
30-A2073	Extension Arm, Short	1
30-A2074	Extension Arm, Compact	1
30-A2164	Extension Arm, Extra Long	1

**Options**

E1-13049	8 Cond. RJ45 to RJ45 50 ft.
30-08101	Doorbell Switch
30-A2044	Lighted Doorbell Switch
30-A2198	8 inch Rectangular Cone
22-11466	8mm Adjustment Wrench
22-11467	Fluorescent Screen
30-A2099	4x4 Mount Kit

## Installing the Control Unit on a Single Wood Stud Wall

Mark and Drill  
Control Unit  
Mounting Holes

**WARNING:**  
**UNDER NO CIRCUMSTANCES SHOULD THE 82 INCH [208 CM] REACH SYSTEM BE ATTACHED TO A WALL IN THE SINGLE STUD CONFIGURATION. PLEASE DIRECT ANY QUESTIONS ON THIS MATTER TO MIDMARK TECHNICAL SUPPORT.**

**WARNING:**  
**LAG SCREWS ARE NOT INTENDED TO BE USED AS AN ATTACHMENT METHOD FOR METAL SUPPORTS. MIDMARK PROVIDES MACHINE SCREWS, LARGE FLAT WASHERS AND NYLOCK NUTS TO USE WHEN FASTENING THE SYSTEM TO METAL SUPPORTS.**

### **SINGLE STUD INSTALLATION WITH THE “INSTALLATION GUIDE” (30-P0076).**

#### **Introduction**

The Installation Guide is intended to be a positive means of locating the center of a 2x4 wooden stud. The Installation Guide is a necessary part of the installation and *must be used* whenever single stud installations are performed. The Installation Guide is equipped with side tabs which can be removed if placement of the Guide is obstructed by an electrical box. During installations which include attachment to a 4x4 wooden stud, all of the tabs, on one side of the guide, can be removed in order to facilitate adequate placement and attachment.

1. Locate the wooden stud.



2. Make a small opening in the wall to positively identify the position of the wooden stud.



3. Draw an outline of the installation guide on the wall, ensuring that the vertical height matches the requirements set forth on the “Wall Mount Template” (30-S0003). Open the wall so that the installation guide will rest directly on the wooden stud.



4. Place the installation guide on the wooden stud.  
If the surface of the Installation Guide falls below the surface wall, a correspondingly longer fastener must be chosen.



5. Drill two 5/32 inch diameter holes using the installation guide as a drill template.



6. Attach the wall mounted control, leaving the installation guide in place.



**Remove Control Unit Front Cover**

1. Open the shipping carton and locate the Control Unit in the first level of the carton.
2. Remove the Phillips screw from the front cover of the Control Unit.
3. Carefully remove the front cover.
4. Place the front cover and the screw in a safe location for later reassembly.

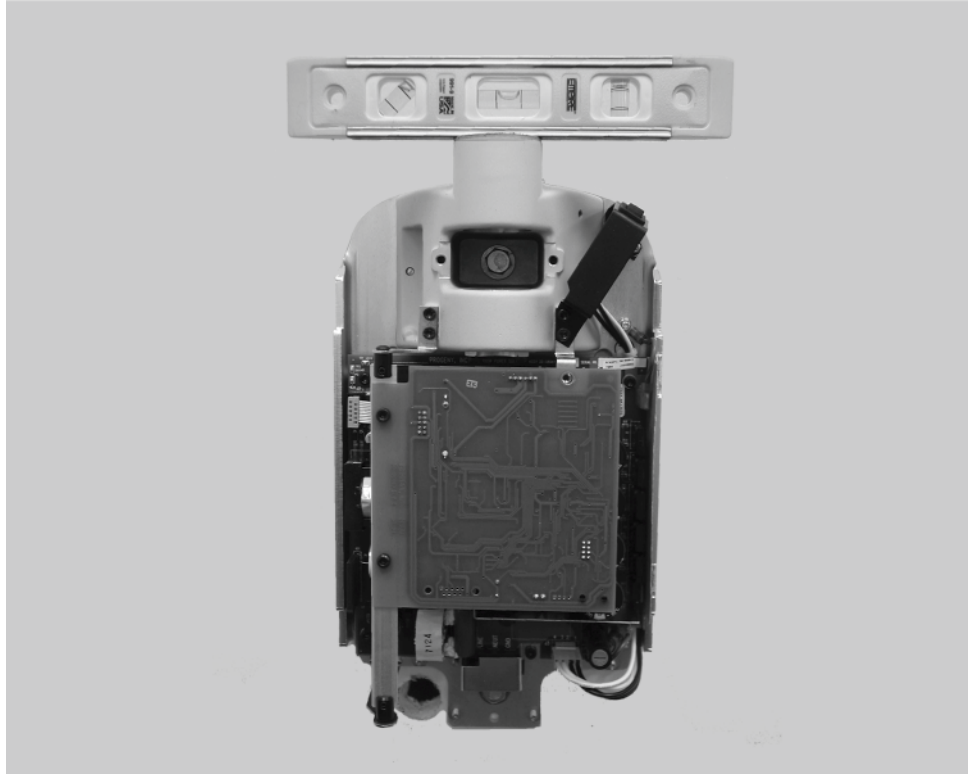
**Mount and Level the Control Unit**

1. Select the 3/8" x 3" long lag screws [30-H0006] and washers [30-H0008].  
**Note:** For concrete walls, the installer must supply the appropriate mounting bolts.
2. Put a lag screw and washer through the upper mounting hole of the Control Unit.
3. Place the Control Unit on the wall and loosely tighten the upper mounting bolt.
4. Put the remaining lag screw and washer through the lower mounting hole of the Control Unit and loosely tighten. Be sure that the power wire extends through the opening at the bottom of the Control Unit.
5. Place a level on the Control Unit bearing parallel to the wall, as shown in *Figure 14*. Level the Control Unit.
6. Tighten the upper and lower lag screws to 14–18 ft-lbs [2.0 to 2.5 m-kgs].
7. Pre-drill a hole for a # 12 wood screw below the lower lag screw, as shown in *Figure 15*. Install and tighten the wood screw to prevent the unit from shifting.

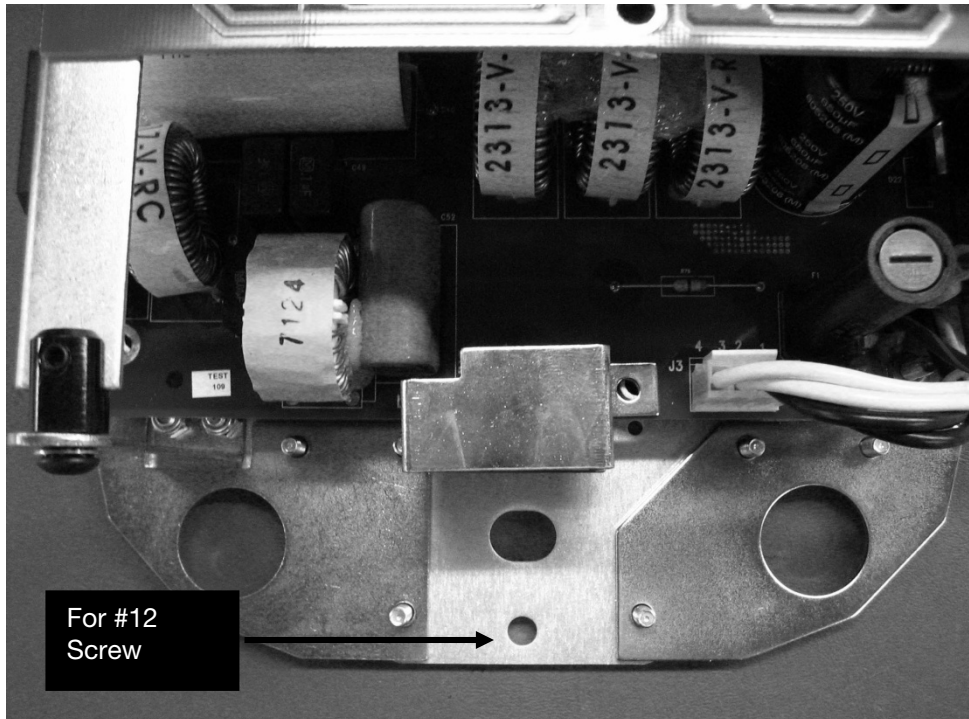
**CAUTION!**

**Do not over tighten the lag screws. Over tightening the lag screws will damage the wooden stud and reduce the holding force.**

**Figure 14**  
**Leveling the**  
**Control Unit**



**Figure 15**



## Installing the Control Unit on a Dual Wood Stud Wall

### Mark and Drill Wall Plate Mounting Holes

The mounting template [30-S0003] is a guide for locating where to drill the holes used to mount the wall plate to the wall. Carefully placing the mounting template for two stud mount installations on the wall will help ensure correct installation of the mounting plate and, hence, the Control Unit.

1. Using a stud finder, locate the center of the studs on which the wall plate will be mounted.
2. Place the mounting template for the two stud mount on the wall with the lower mounting holes 40 inches [101.5 cm] above the floor.
3. Place a level parallel to the vertical lines on the mounting template and adjust the mounting template until it is plumb.
4. Tape the mounting template to the wall.
5. Using an awl or other sharp object, punch through the mounting template to mark the location of the mounting holes.
6. Drill 5/32" pilot holes (for common pine studs) at the marked locations.
7. Remove the mounting template from the wall and save for future use.

### Install the Wall Plate (30-A2042)

In the dual wood wall stud installation, the Control Unit is bolted to a wall plate that has been installed on two wood studs. The wall plate, shown in *Figure 16*, is packaged separately from the Preva.

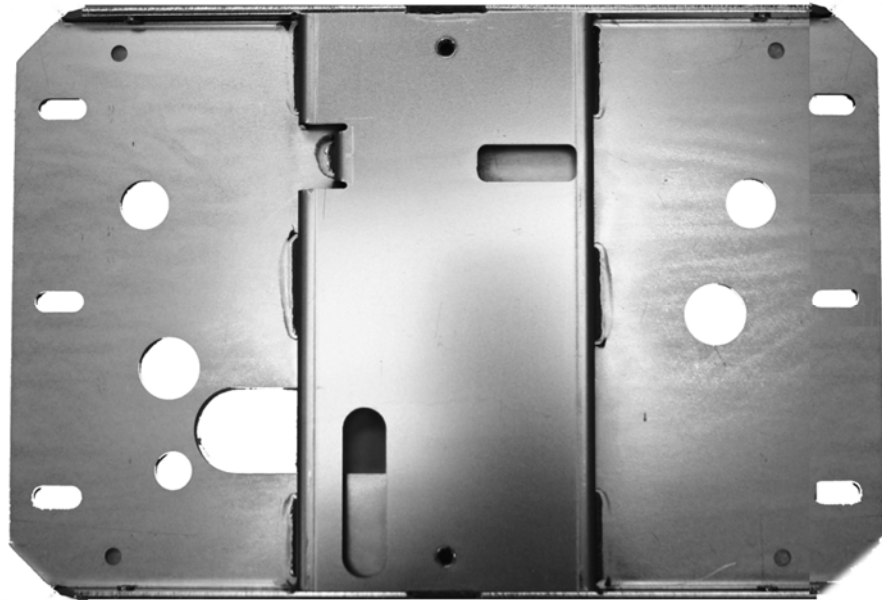
1. Select the 3/8" x 3" long lag screws [30-H0006] and washers [30-H0008].
2. Put the lag screws and washers through the mounting holes on the wall plate and loosely tighten. Be sure that the power wire extends through the opening in the wall plate.
3. Level the wall plate.
4. Tighten the lag screws to 14–18 ft-lbs [2.0 to 2.5 m-kgs].

#### **CAUTION!**

**Do not over tighten the lag screws. Over tightening the lag screws will damage the wooden stud and reduce the holding force.**



**Figure 16**  
**Mounting Plate for**  
**Dual Stud Wall**  
**Mounts**



**Remove Control**  
**Unit Front Cover**

1. Open the shipping carton and locate the Control Unit in the first level of the carton.
2. Remove the Phillips screw from the front cover of the Control Unit.
3. Carefully remove the front cover.
4. Place the front cover and the screw in a safe location for later reassembly.

**Mount the**  
**Control Unit**

1. Select the 5/16"-18 x 7/8" long socket cap screws [H1-15-S23088-01] and washers [H1-NA-S12000-01].
2. Put the one screw and washer through the upper mounting hole of the Control Unit.
3. Place the Control Unit on the wall and loosely tighten the upper screw.
4. Put the other screw and washer through the lower mounting hole of the Control Unit and loosely tighten. Be sure that the power wire extends through the opening at the bottom of the Control Unit.
5. Place a level on the Control Unit bearing parallel to the wall. Level the Control Unit.
6. Tighten the upper and lower screws.
7. After the Preva is installed, slide covers on the wall plate and fasten with the provided (8) screws [H1-64-S17050-01].

## Installing the Control Unit on a Metal Stud Wall

### Mark and Drill Wall Plate and Support Plate Mounting Holes

The mounting template [30-S0003] is a guide for locating where to drill the holes used to mount the wall plate and support plate to the wall. Carefully placing the mounting template on the wall will help ensure correct installation of these plates and, hence, of the Control Unit.

1. Using a stud finder, locate the center of the stud on which the Control Unit will be mounted.
2. Place the mounting template for the dual stud mount on the wall with the lower mounting holes 40 inches [101.5 cm] above the floor.
3. Place a level parallel to the vertical lines on the mounting template and adjust the mounting template until it is plumb.
4. Tape the mounting template to the wall.
5. Using an awl or other sharp object, punch through the mounting template to mark the location of the mounting holes.
6. Drill ¼-inch pilot holes at marked locations.
7. Drill 1-inch clearance holes.
8. Remove the mounting template from the wall and save for future use.

### Reinforce Metal Stud Wall

Filler material is added to the wall to prevent the metal stud wall from being crushed during installation.

1. Cut an access hole 6 inches by 10 inches [15 cm x 25 cm] in size between the clearance holes.
2. Insert two 4x4 wooden studs in the access hole. Attach the studs to the rear drywall surface with drywall screws.

#### **CAUTION!**

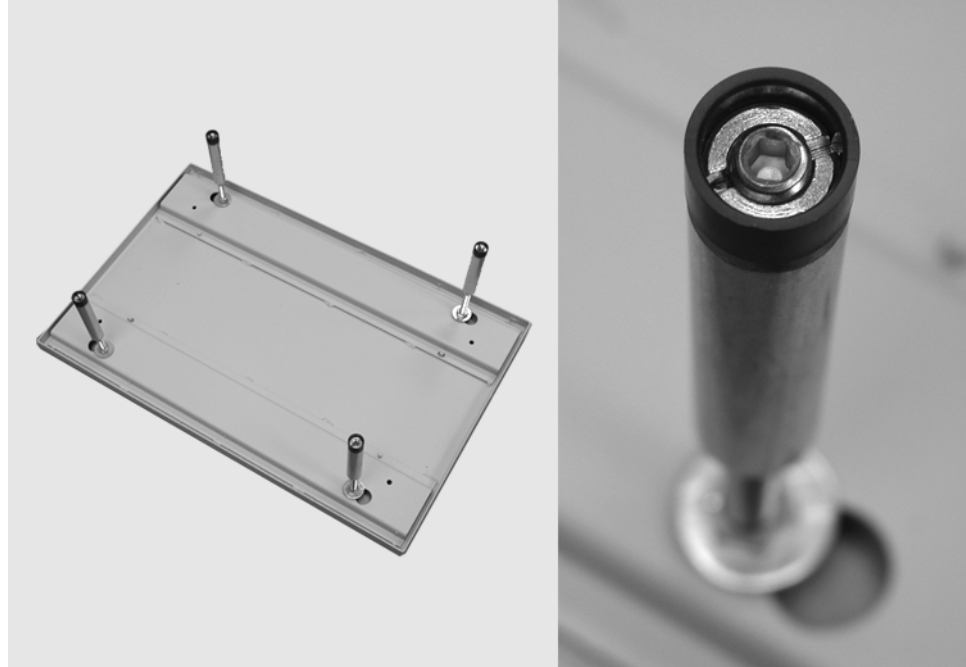
**The sheet metal stud wall must be secure to hold a load of 850 ft. lbs. [118 kg.m.].**

### Assembling and Mounting the Support Plate (30-A2043)

In the metal wall stud installation, the Control Unit is bolted to a wall plate (*Figure 16*) that has been installed to the support plate shown in *Figure 17*. The wall and support plates are shipped in separate cartons from the Preva.

1. Put the small, then the larger washers and nut on each of the four carriage bolts.
2. Insert the carriage bolts into the support plate holes.
3. Screw the threaded standoffs onto the carriage bolts with the slotted ends away from the back plate.
4. Place the plastic sleeve bearings in the slotted ends of the carriage bolts.
5. Using a 5/32 Allen key, insert a set screw into each threaded standoff. Screw the set screw until just below the slot in the threaded standoff, but do not tighten.
6. Using two sheet metal screws mount and level the support plate through the pilot holes on the back side of the wall. Tighten the sheet metal screws with the screw driver.
7. On the front side of the wall, using a straight-blade screw driver, adjust the threaded standoffs until the plastic part is flush with the drywall.
8. Tighten the set screws in the threaded standoffs to lock them in place.

**Figure 17**  
**Support Plate for**  
**Metal Stud Wall**  
**Mount**



**Install the Wall**  
**Plate (30-A2042)**

1. Select the 5/16"-18 x 1" long hex bolts [H1-00-S23100-01].
2. Put the hex bolts through the mounting holes on the wall plate and loosely tighten. Be sure that the power wire extends through the opening in the wall plate.
3. Level the wall plate.
4. Tighten the hex bolts

**Remove Control**  
**Unit Front Cover**

1. Open the shipping carton and locate the Control Unit in the first level of the carton.
2. Remove the socket flathead screw from the front cover of the Control Unit.
3. Carefully remove the front cover.
4. Place the front cover and the screw in a safe location for later reassembly.

**Mount the**  
**Control Unit**

1. Select the 5/16"-18 x 7/8" long socket cap screws [H1-15-S23088-01] and washers [H1-NA-S12000-01].
2. Put the one screw and washer through the upper mounting hole of the Control Unit.
3. Place the Control Unit on the wall and loosely tighten the upper screw.
4. Put the other screw and washer through the lower mounting hole of the Control Unit and loosely tighten. Be sure that the power wire extends through the opening at the bottom of the Control Unit.
5. Place a level on the Control Unit bearing parallel to the wall. Level the Control Unit.
6. Tighten the upper and lower screws.
7. After the Preva is installed, slide covers on the wall plate and fasten with the provided (8) screws [H1-64-S17050-01].

## Installing the Horizontal Arm and Brake Assembly

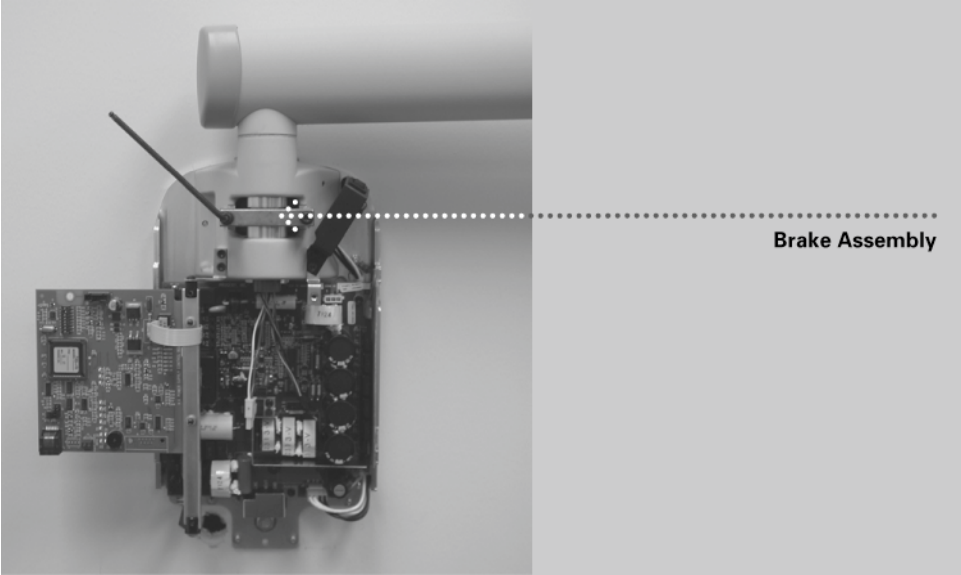
### Installing the Horizontal Arm and Brake Assembly

1. Locate the Horizontal Arm in the top level of the shipping carton.
2. Remove the Horizontal Arm from the shipping carton. **Do not remove** the cardboard tube around the wires but remove the red tag. Insert the cardboard tube snugly into the shaft of the Horizontal Arm.  
**Note:** Do not lubricate the shaft of the Horizontal Arm or bearings in Control Unit.
3. Insert the cardboard tube enclosing the wires into the opening in the top of the Control Unit.
4. Insert the Horizontal Arm completely into the Control Unit, as shown in *Figure 18*. Ensure that the Horizontal Arm is firmly seated in place.
5. Remove the cardboard tube to free the wires. Discard the cardboard tube.  
**Note:** Do not make the wire connections at this time.
6. Locate the brake assembly 30-A2024 in the kit pack (30-A2049 or 30-A2156). As shown in *Figure 19*, install and loosely tighten the brake assembly in order to put a small amount of drag on the rotation of the Horizontal Arm and to keep the Horizontal Arm from lifting out.

Figure 18 Installing the Horizontal Arm



**Figure 19**  
**Installing the Brake**  
**Assembly**



## Installing the Articulating Arm and Tubehead Assembly

### Install the Articulating Arm and Tubehead Assembly

The Tubehead and Articulating Arm are installed as a single unit.

1. Remove the top level packing material from the shipping carton to gain access to the Articulating Arm and Tubehead Assembly. **Do not remove** the cardboard tube enclosing the cable wires but remove the red tag.
2. Remove the Articulating Arm and Tubehead Assembly from the shipping carton.

#### **CAUTION!**

**Do not remove the tie holding the Articulating Arm closed. Removing the tie will cause the Articulating Arm to spring open, potentially causing personal injury.**

**Note:** Do not lubricate the shaft of the Articulating Arm or the bearings in the Control Unit.

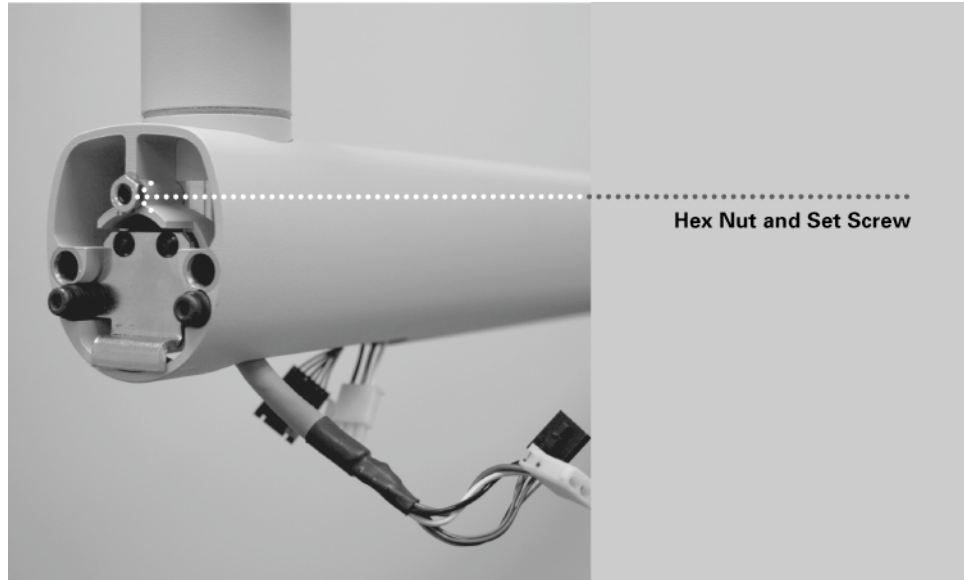
3. Position the Articulating Arm above the Horizontal Arm.
4. Carefully route the cardboard tube with the arm cable plug through the opening in the Horizontal Arm.
5. Insert the shaft of the Articulating Arm into the opening in the Horizontal Arm, as shown in *Figure 20*.
6. Press down until the shaft is completely seated in the Horizontal Arm.
7. Remove the cardboard tube to free the wires. Discard the cardboard tube.
8. Untie the Articulating Arm and remove the plastic covering.

**Figure 20** Installing the Articulating Arm and Tubehead Assembly

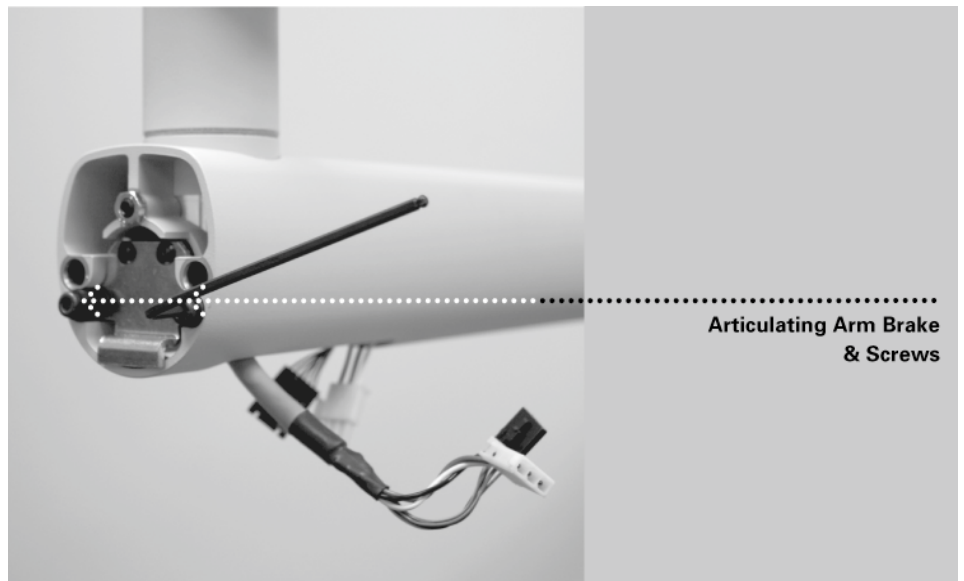


### Install the Articulating Arm Brake Assembly

1. Locate the Articulating Arm brake assembly (30-A2068).
2. Insert the M6 x 25 mm long set screw, as shown in *Figure 21*. Using a 3 mm Allen wrench, tighten the screw fully then back off  $\frac{1}{4}$  turn and secure with the hex nut.
3. Using a 3 mm Allen wrench, install the Articulating Arm brake. Tighten screws until the Articulating Arm brake comes into contact with the shaft of the Articulating Arm. If additional friction is required to prevent drifting, turn the two screws evenly  $\sim\frac{1}{4}$  turn at a time until drift stops, as shown in *Figure 22*.



**Figure 21**  
Installing the Hex  
Nut and Set Screw



**Figure 22**  
Adjusting the  
Articulating Arm  
Brake Assembly

## Connecting the Cables

### Connecting the Articulating and Horizontal Arm Cables

1. Connect the two Articulating Arm cables to the Horizontal Arm cables, as shown in *Figure 23* and *Figure 24*.
2. Once the connections are made, dress the cables and push them into the opening in the Horizontal Arm.



**Figure 23**  
Connecting the Articulating Arm and Horizontal Arm Cables



**Figure 24**  
Connecting  
optional  
Integrated  
Sensor Cable



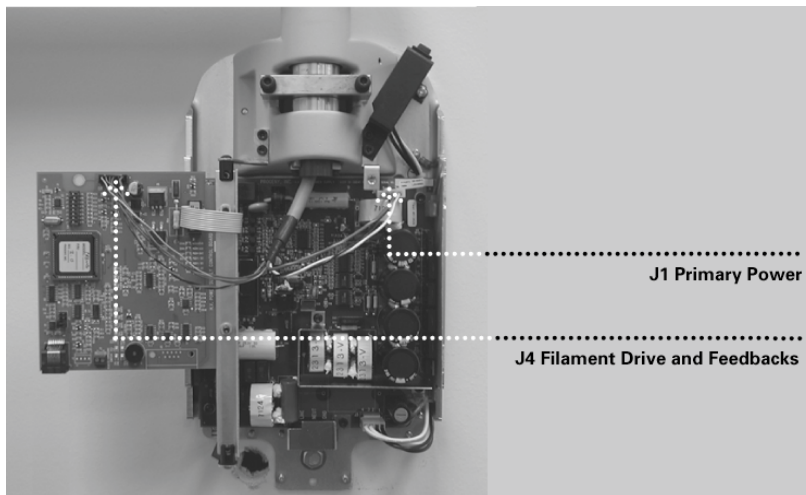
Connecting  
the  
Horizontal  
Arm Cables  
to the  
Power  
Supply  
Board

**CAUTION!**

**Verify that line power is disconnected before proceeding.**

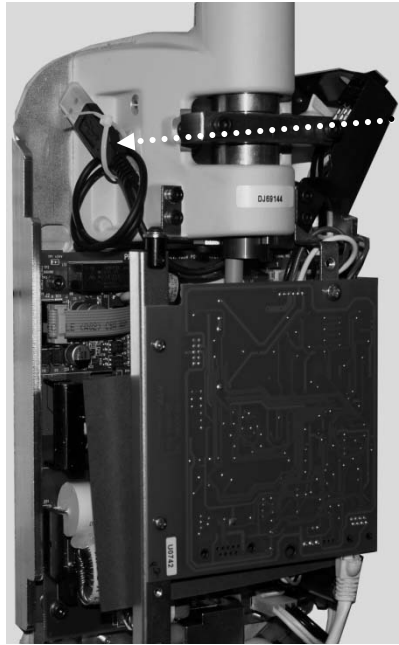
1. Attach the black connector from the Horizontal Arm to point J4 of the Power Supply Control Board [30-08160], as shown in *Figure 25*.  
**Note:** The plug must be properly oriented. Be sure that the tabs on the connector are down.
2. Attach the white connector from the Horizontal Arm to point J1 on the Power Supply Board 30-08041, as shown in *Figure 25*.  
**Note:** The plug must be properly oriented. Be sure that the tabs on the connector are down.

**Figure 25**  
Connecting  
the Horizontal  
Arm Cables to  
the Circuit  
Boards



### Optional Integrated Sensor

1. Optional integrated sensor cable. Tie-wrap the USB cable to the tie block provided as shown in *Figure 26*.

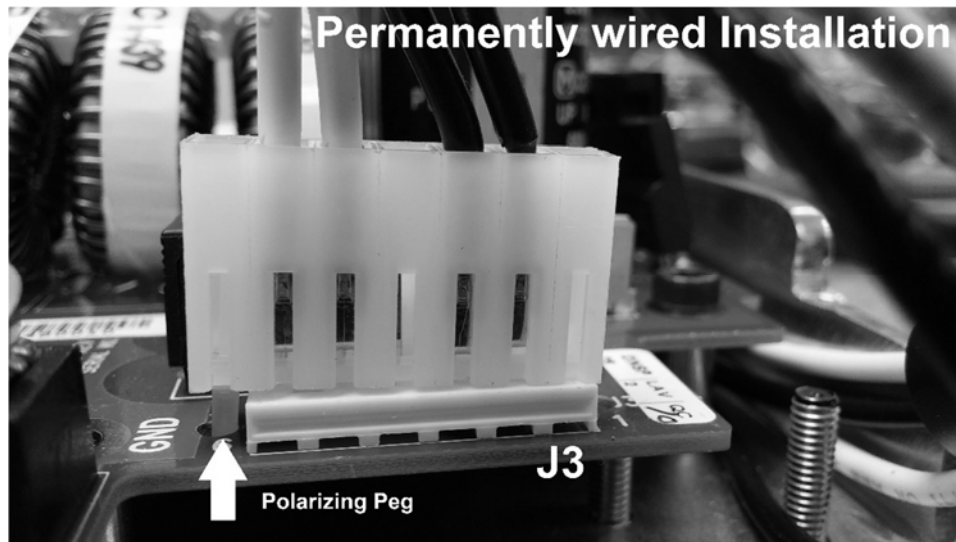


**Attach provided tie block here, loop and tie the cable to the tie block.**

**Figure 26**  
Tying optional  
sensor cable  
out of harm's  
way

### Connecting Line Power, Permanently Wired Installation

1. Using a 3 mm Allen wrench, remove the power line terminal strip cover at the base of the Power Supply Control Board to gain access to the power line terminal strip, as shown in *Figure 30*.
2. Attach the hot (black) wire of the mains to the connection identified as LINE on the power strip.
3. Attach the neutral (white) wire of the mains to the connection identified as NEUT on the power strip.
4. Attach the ground (green) wire of the mains to the connection identified as GND on the power strip.
5. The connector from the power switch harness at J3 of the Power Supply Control Board should be left in the default position as shown in *Figure 27*.
6. Leave the power line terminal strip cover off until the following electrical verification procedure is complete.

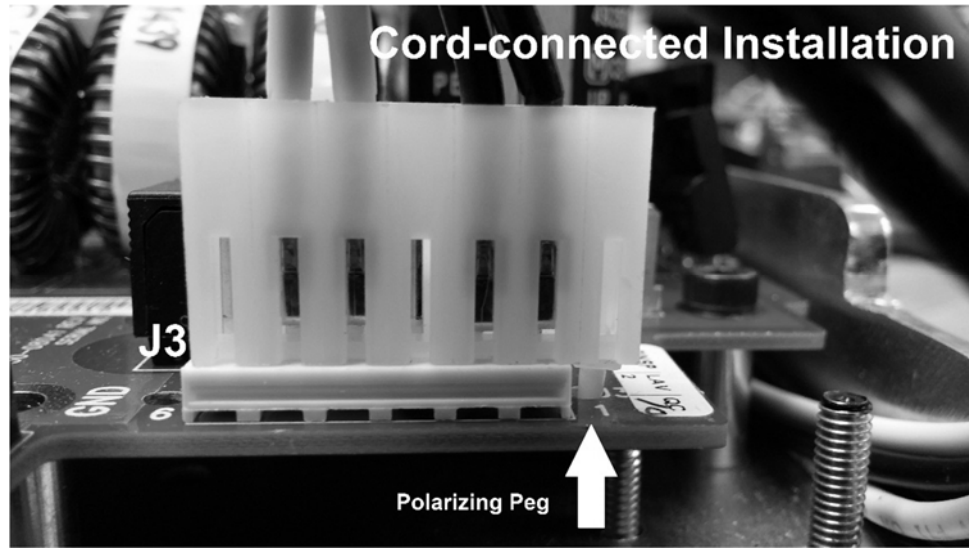


**Figure 27**  
**Power Switch**  
**Harness**  
**Configuration**  
**for**  
**Permanently**  
**Wired**  
**Installation**

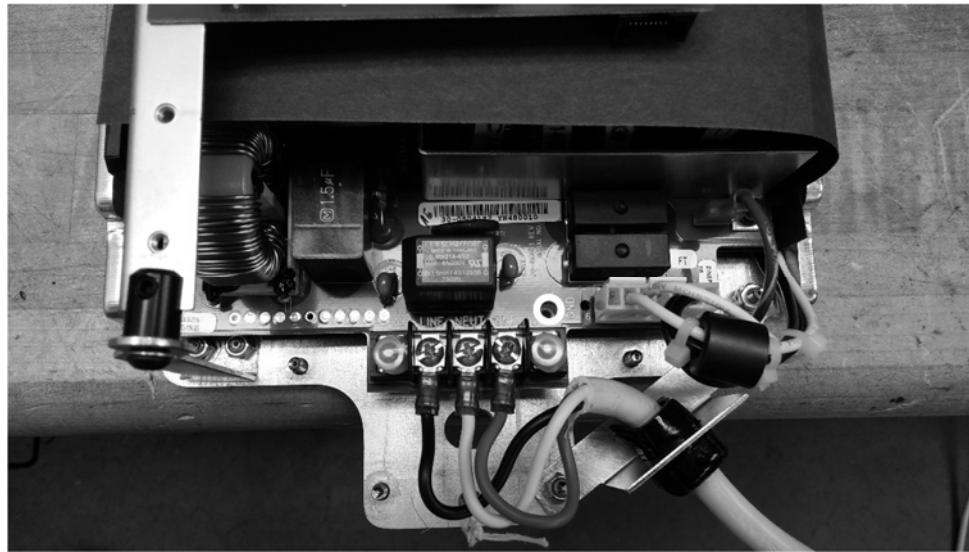
### Connecting Line Power, Cord-Connected Installation

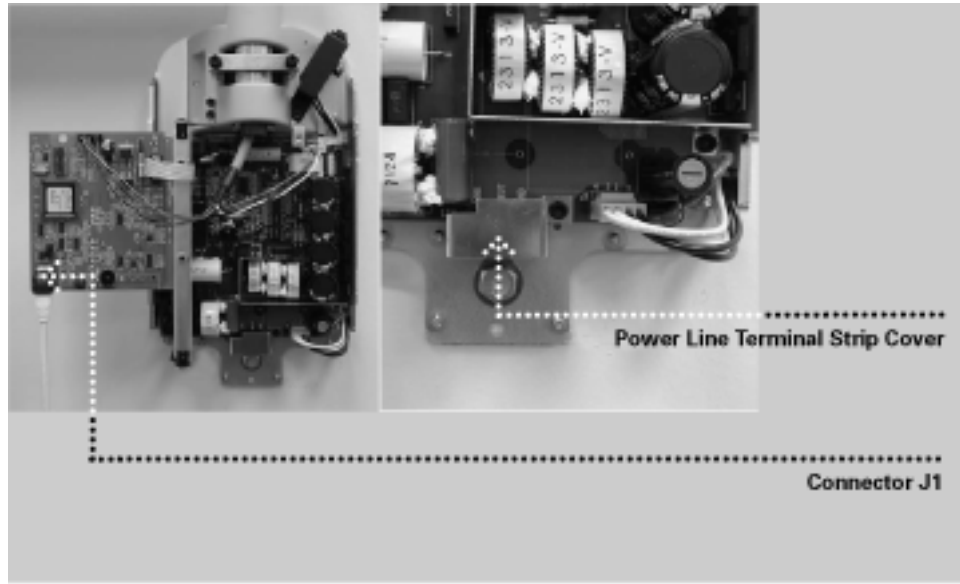
1. Using a 3 mm Allen wrench, remove the power line terminal strip cover at the base of the Power Supply Control Board to gain access to the power line terminal strip, as shown in *Figure 30*.
2. Connect the flanged spade lug of the hot (black) wire of the power cord to the connection identified as LINE on the power strip.
3. Connect the flanged spade lug of the neutral (white) wire of the power cord to the connection identified as NEUT on the power strip.
4. Connect the flanged spade lug of the ground (green) wire of the power cord to the connection identified as GND on the power strip.
5. Remove the connector from the power switch harness at J3 of the Power Supply Control Board.
6. Remove the Polarizing Peg from position 7 of the connector. Use a needle nose plier to rotate the polarizing peg 45 degrees and pull to remove it.
7. Insert the polarizing peg into position 1 of the connector.
8. Reconnect the connector to J3 of the Power Supply Control Board. Align the polarizing peg as shown in *Figure 28*.
9. Attach the bracket and strain relief as shown in *Figure 29*.
10. Leave the power line terminal strip cover off until the following electrical verification procedure is complete.

**Figure 28**  
**Power Switch**  
**Harness**  
**Configuration**  
**for Cord-**  
**Connected**  
**Installation**



**Figure 29**  
**Power Cord**  
**Anchoring**





**Figure 30**  
**Power Line**  
**Terminal**  
**Strip Cover**

**Connecting**  
**the**  
**Operator**  
**Panel with**  
**the 25 ft.**  
**Cable**

During initial powerup and verification, the Operator Panel is required. Connect the Operator Panel with the 25 ft. [7.62 m] interconnect cable. Later you will connect the Operator Panel in its final position for use.

1. Identify the Operator Panel and the 25 ft. [7.62 m] interconnect cable.
2. Plug the cable into the left socket at the base of the Operator Panel.
3. Plug the other end of the cable into connector J1 on the Power Supply Control Board 30-08160, as shown in *Figure 30*.

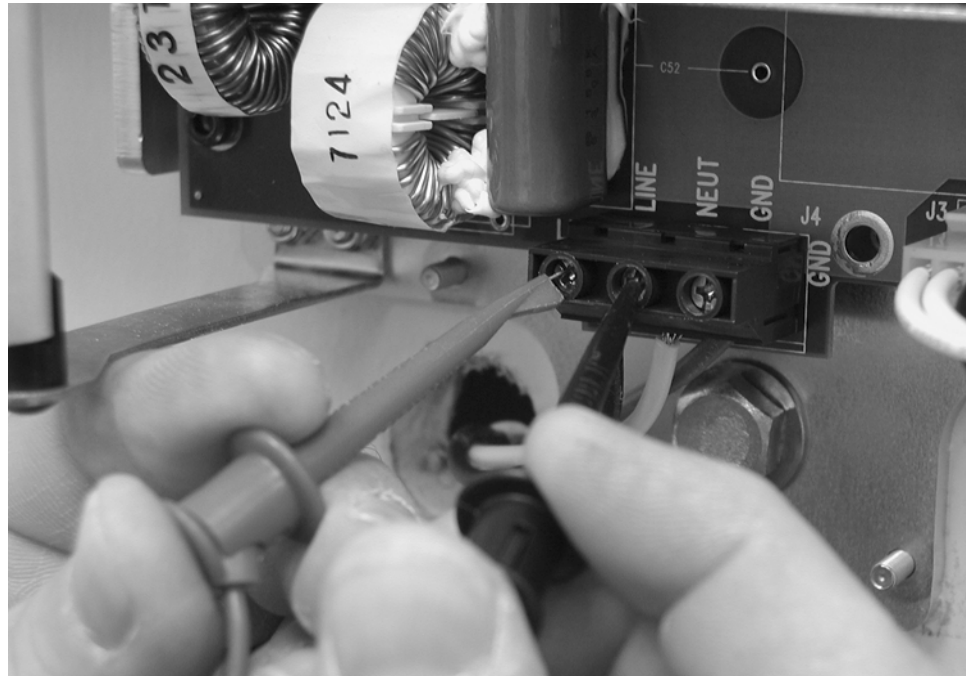
## Electrical Verification

### Calibration

Calibration of the Preva Dental X-ray System is preset at the factory and is not required during initial installation. Service replacement of the Power Supply Control Board 30-08160 or the Tubehead may require calibration. See the Calibration section of this manual.

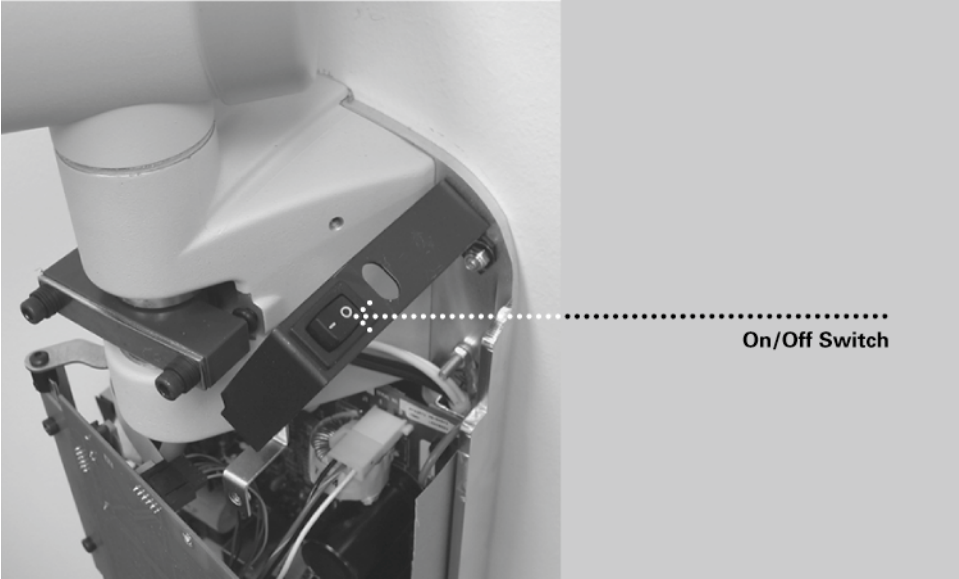
### Verifying Input Voltage and Turning On the System

1. Before turning on the system, verify the input voltage by measuring the voltage at LINE and NEUT, as shown in *Figure 31*. The reading should be within the range of 100–250V.
2. Replace the power line terminal strip cover.
3. Turn on the Preva Dental X-ray System using the power switch, as shown in *Figure 32*. On the Operator Panel, *Figure 33*, you will see the product display screen showing the software version. Then the Operator Panel will display the default technique factors.



**Figure 31**  
Verifying Input  
Voltage at the Line  
Input

**Figure 32**  
Turning on the  
Power



**Figure 33**  
Operator Panel

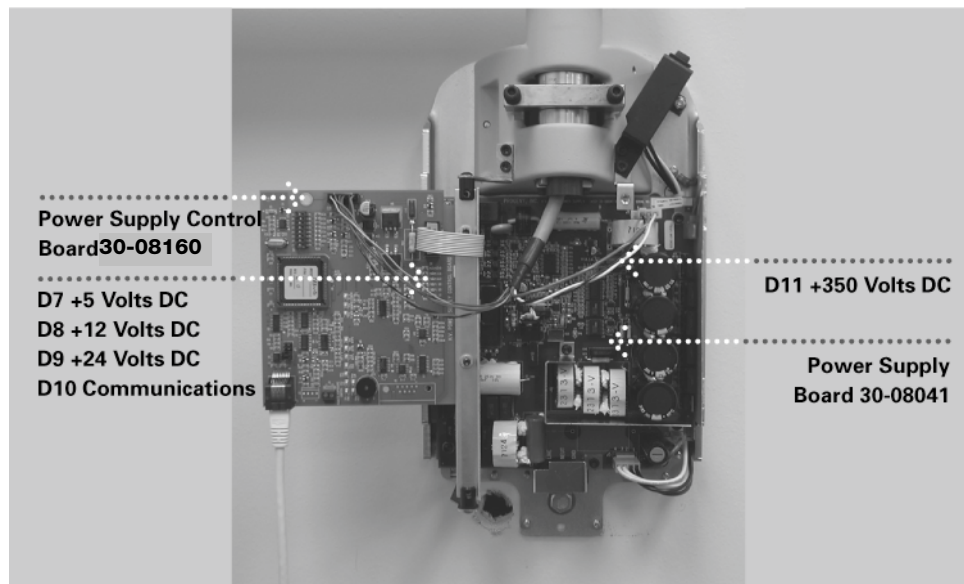


## Circuit Board Verification

### **CAUTION!**

**The Power Supply Board 30-08041, when energized, contains high electrical energy. Avoid contact with this board. After the system is turned off, electrical energy will remain in the Power Supply Board for several minutes. When attempting any service on this board, first verify that voltage has dissipated.**

1. On Power Supply Board 30-08041, shown in *Figure 34*, verify that LED D11 is illuminated. The illuminated LED verifies that appropriate supply voltages are present.  
**Note:** Stored electrical energy is present whenever D11 is illuminated.
2. On the Power Supply Control Board 30-08160, shown in *Figure 34*, verify that LEDs D7 (+5VDC), D8 (+12VDC) and D9 (+24VDC) are illuminated and LED D10 is flashing. Each illuminated LED verifies that appropriate supply voltages are present. If the LEDs are not illuminated, refer to the “No Operator Display but Power Switch is On” procedure in the Troubleshooting on page 69 of this manual.
3. Turn off the Preva Dental X-ray System using the power switch as shown in *Figure 32*.



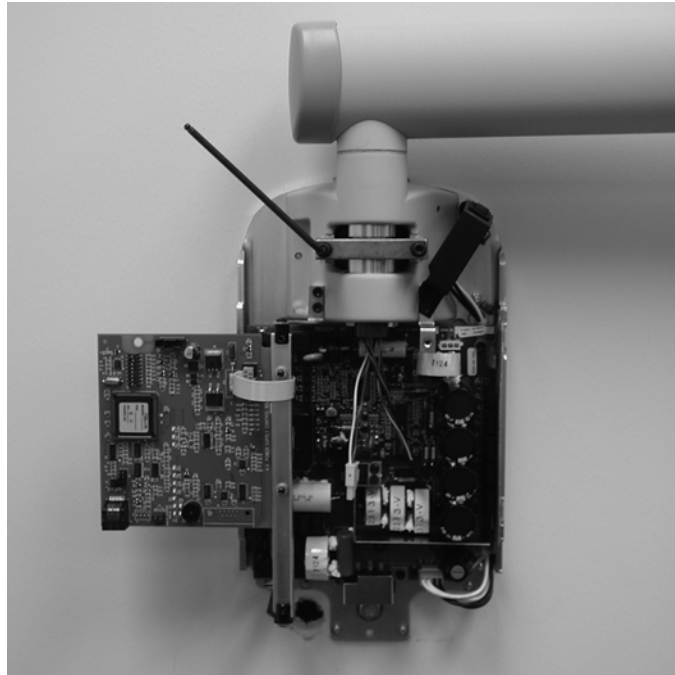
**Figure 34**  
**Circuit Board**  
**Verification**



## Mechanical Adjustments

### Horizontal Arm Adjustment

1. Locate the brake assembly at the top of the Control Unit. The brake assembly has a screw on either side of a clamping bar over the Horizontal Arm pivot post.
2. Using a 4 mm Allen wrench, as shown in *Figure 35*, tighten the screws equally to apply adequate braking to the pivot post so that Horizontal Arm begins to move after the Articulating Arm.



**Figure 35**  
Tightening the  
Brake

### Additional Adjustments

The balance and friction of the Articulating Arm are preset at the factory. During the installation process, check the balance and friction. When moving the Tubehead, the Articulating Arm should be steady in all positions and move before the Horizontal Arm. If adjustments are necessary, follow the adjustment procedures in the Troubleshooting section on page 68 of this manual.

**Note:** The mechanical adjustments should not be used to compensate for a system that is not properly leveled on the wall.

## Installing the Control Unit Front Cover and the Operator Panel

### Important Note

The Operator Panel can be installed on the Control Unit or remote from the Control Unit. Installation of the Operator Panel on the Control Unit may require the purchase and use of the coil-cord hand switch option 30-A2040.

In order to comply with the regulations and proper X-ray practices, the Operator Panel must be located where the operator can view both the patient and the technique factors prior to the exposure.

### On the Control Unit

1. Connect the short cable at point J1 on the Power Supply Control Board 30-08160.
2. Feed the cable through the front cover of the Control Unit.
3. Place the top of the front cover on the Control Unit and pop the bottom of the cover into place, as shown in *Figure 36*, being careful of the power switch and cover alignment.
4. Replace the screw on the front cover of the Control Unit.
5. Plug the cable into the bottom of the Operator Panel.
6. Snap the Operator Panel into place on the front cover of the Control Unit, as shown in *Figure 37*.



**Figure 36**  
Placing the Cover  
on the Control Unit



**Figure 37**  
**Snapping in the**  
**Operator Panel**

## Remote Operator Panel

In the remote location, the Operator Panel snaps to the Operator Panel mounting cradle, which is first mounted on the wall.

1. Place and level the mounting template [30-S0003], shown in *Figure 8*, at eye level in the location where the Operator Panel is to be installed. Tape the mounting template to the wall.
2. Using an awl or other sharp object, punch through the mounting template to mark the location for the bolts for the Operator Panel mounting cradle.
3. Drill pilot holes at marked locations. With a drywall knife, cut an opening as shown on the mounting template.
4. Remove the mounting template from the wall.
5. Using the anchors and screws from the mounting hardware packet, install the Operator Panel mounting cradle in the position marked.
6. Locate the 25 ft [7.6 m] remote control cable.
7. Run the remote control cable, in compliance with local codes, from the intended location of the remote Operator Panel to the back of the Control Unit.

**Note:** The cable can also be run to an electrical box or opening at the top left of the wall plate assembly. A sufficient length of cable should be left available to bring the remote cable out to the bottom front of the Control Unit.

8. Plug the remote control cable into the bottom of the Power Supply Control Board 30-08160.
9. Place the top of the front cover on the Control Unit and pop the bottom of the cover into place, as shown in *Figure 36*, being careful of the power switch and cover alignment.
10. Replace the screw on the front cover of the Control Unit.
11. Place the cover plate over the top opening and the small trim cover over the bottom opening on the front cover of the Control Unit.
12. Locate the Operator Panel in the top portion of the shipping carton.
13. Connect the other end of the remote cable to the right plug (as viewed from the back) on the bottom of the Operator Panel.
14. Carefully dress the white cable back into the wall.
15. Snap the Operator Panel to the mounting cradle, as shown in *Figure 38*.

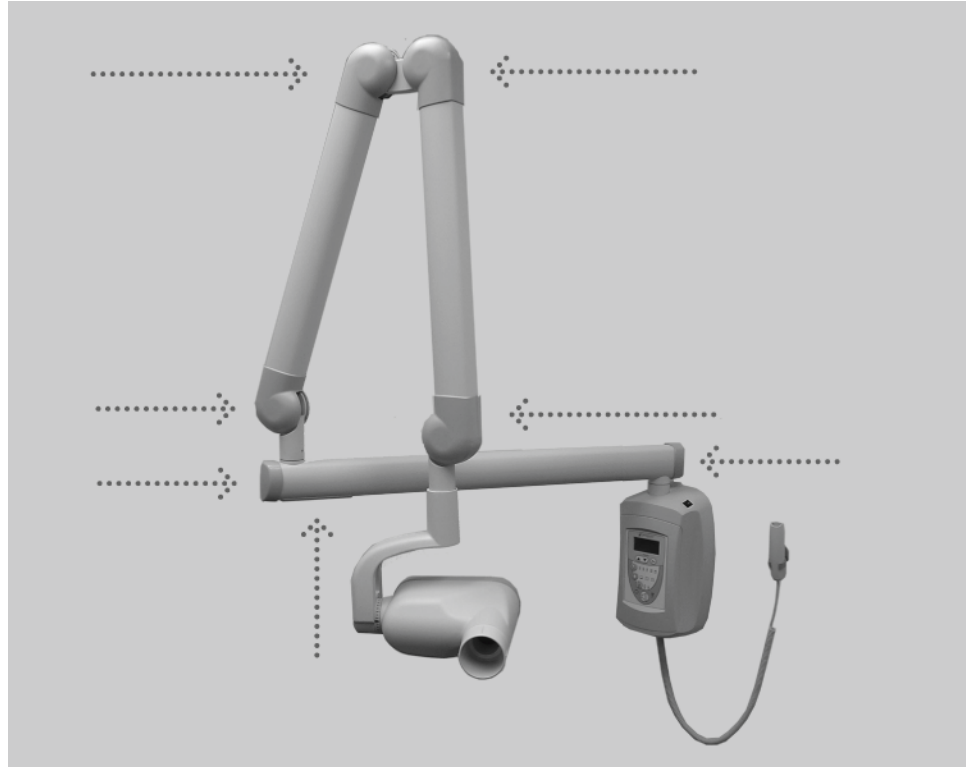
**Figure 38**  
**Snapping the**  
**Operator Panel to**  
**the Mounting**  
**Cradle**



## Installing Plastic Covers

The end cap for the Horizontal Arm is shipped in the packet of plastic parts and is put on as part of the installation procedures. End caps for the Articulating Arm are shipped installed but are removable to perform mechanical adjustments. The cable access cover is placed over the cable connection underneath the Horizontal Arm. Cover locations are shown in *Figure 39*.

1. Place the plastic cover from the packet on the end of the Horizontal Arm.
2. Install the cable access cover over the Horizontal Arm opening using two Phillips flat-head screws.



**Figure 39**  
**Cover Locations**

## Preva Operator Panel

### Using the Operator Panel

#### Power On Settings

When the Preva Dental X-ray System is powered on, the Operator Panel, shown in *Figure 40*, displays the selections that were in use when the system was last powered off.

#### Exposure Settings

The Operator Panel displays the exposure settings (kV, mA, and seconds) for the currently selected tooth, image receptor type, and patient size. Use the Tooth Selection, Image Receptor Type, and Patient Size buttons to select other exposure settings.

#### Adjusting Exposure Settings

Preset exposure settings can be adjusted prior to making an exposure. Exposure time can be easily changed by simply using the up and down buttons. To adjust kV and mA, use the right arrow to select the exposure setting to adjust. Then use the up and down arrow buttons to adjust the value. To save new presets, use the System Configuration mode described on page 62 in this manual.

#### Exposure Button and Ready Indicator

The Exposure button is used to initiate an X-ray exposure. For a complete exposure, the button must be pressed and held until the Radiation Indicator no longer illuminates and the audible signal is no longer heard. Releasing the Exposure button immediately terminates the X-ray exposure.



**Figure 40**  
Preva Operator  
Panel

## Checking System Functions

The following checks must be performed to complete the installation of the Preva Dental X-ray System and as part of the recommended maintenance as indicated in the User Manual. Failure to perform these checks may result in an installation that does not comply with U.S. Radiation Performance Standards 21 CFR Subchapter J.

**CAUTION!**

**If the Preva Dental X-ray System does not perform the functions below, advise the owner that the system is not to be used. See the Troubleshooting section of this manual on page 68 or contact Midmark's Technical Support.**



<b>System Function Checklist</b>		✓
<b>Wall Mounting</b>	Ensure that the wall support is adequate and that the system is properly mounted to the wall.	
<b>Labels</b>	Ensure that all certified components bear labels that include the model and serial number, date of manufacture, and a statement of certification as noted elsewhere in this manual.	
<b>Tubehead</b>	Check for oil leaks or other evidence that could indicate internal damage. Replace the Tubehead, if necessary.	
<b>Tubehead Rotation</b>	Ensure that the Tubehead maintains its position around the horizontal axis while remaining easy to rotate and position. Also check the vertical pivot of the Tubehead for easy movement while remaining in position after moving.	
<b>Suspension</b>	Check that all movements are smooth and quiet. Verify that the Tubehead is properly counterbalanced for vertical drift and that the Horizontal and Articulating Arms do not drift horizontally.	
<b>Power Switch</b>	Verify that the switch is working properly and that the Ready Indicator is illuminated when the power switch is in the ON position.	
<b>Operator Panel Controls</b>	With the power switch, located at the upper right of the Control Unit, in the ON position, verify that technique factors appear on the Operator Panel. Also, check the function of the selection buttons for Tooth Selection, Image Receptor Type and Patient Size. Pressing a selection button should cause indicator lamps to indicate the selected item.	
<b>Exposure Button</b>	Verify that the Exposure button on the Operator Panel is functioning properly. To make an exposure, press and hold the Exposure button until the Radiation Indicator is extinguished and the audible signal is no longer heard.	
<b>Exposure Indicators</b>	Make several exposures and verify that the Radiation Indicator illuminates and the audible signal is heard.	
<b>Premature Termination</b>	Select the longest exposure time possible using the up and down arrows. Initiate an exposure but release the Exposure button after a brief period of time before the timer terminates the exposure. Verify that the display indicates "Pre-termination Error" and returns to normal operating mode.	
<b>Coil-cord Hand Switch Option</b>	If a coil-cord hand switch is used, inspect the switch housing and coil cord for damage or wear. Replace if evidence of damage is present.	
<b>User Information</b>	Make certain that the user of the system has received the User Manual.	

## Tube Seasoning Procedure

**Note: Do not use this procedure immediately after Tubehead replacement.**

**Refer to Page 67 for the Calibration procedure.**

X-ray tubes that sit dormant for several months can become electrically unstable. To remedy this condition, it is recommended you perform a “new tube seasoning procedure. This process establishes stable high voltage operation and will ultimately extend the life of the tube. Repeat this procedure before returning to normal operation any time the system has been unused for more than two months.

1. Verify system operation.
2. Energize the system.
3. Select 60 kilovolts [kV], 7 milliamperes [mA], and the exposure time of one second.
4. Make five exposures at this level, observing the normal cooling time.
5. Select 65 kilovolts, 7 milliamperes, and the exposure time of one second.
6. Make five exposures at this level, observing the normal cooling time.
7. Select 70 kilovolts, 6 milliamperes, and the exposure time of one second.
8. Make five exposures at this level, observing the normal cooling time.

### Your Responsibilities As An Installer And Service Engineer

**Verification of machine performance after installation** must be performed according to the guidelines identified in the “System Function Checklist” which may be found in the User Manual or, the Installation and Service Manual on page 51.

**Verification of machine performance after maintenance or repair** must be performed according to the guidelines identified in the “System Function Checklist” and the calibration instructions which may be found in the Installation and Service Manual.

## Optional Installation Procedures

### Installing the Coil-cord Hand Switch Option (30-A2040)

#### Jumper Configuration for Coil-cord Hand Switch

The Preva Dental X-ray System can be installed with a coil-cord handswitch (30-A2040). The coil-cord handswitch is used to make exposures, in addition to or replacing the use of the exposure button. Installation of the coil-cord hand switch involves connecting the hand switch into the connector on the bottom of the Operator Panel.

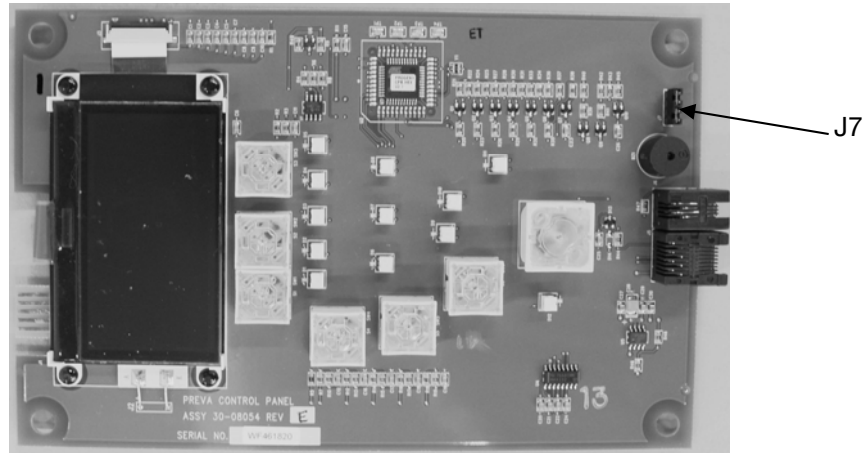
If the coil-cord hand switch is used, it may be required to disable the Exposure button on the control panel (consult your local laws). A jumper must be removed on the Operator Panel Board 30-08054, shown in *Figure 41*, to disable the operation of the hand switch.

1. Turn the power off.
2. Remove the Operator Panel from its mounting on the Control Unit or wall plate.
3. Unplug the cable that connects the Operator Panel to the Control Unit.
4. With a Phillips screwdriver, remove the 4 screws from the back of the Operator Panel. Put the screws in a safe location for later use.
5. Remove the back cover from the Operator Panel. Lift out the Operator Panel Board 30-08054.
6. To disable the use of the Exposure button on the Operator Panel, locate point J7 on the Operator Panel Board 30-08054. Then remove the shunt on J7.
7. Put the Operator Panel Board 30-08054 back in position.
8. Put the cover on the back of the Control Panel using the 4 screws.

#### J7 – Exposure Switch Jumper Settings

Jumper Position	Switch Closure Required for Exposure
1-2, 3-4 (default)	Remote Switch <b>or</b> Panel Switch (parallel)
2,3	Remote Switch <b>and</b> Panel Switch (series)
3,4	Remote Switch (panel switch disabled)

**Figure 41**  
**Disabling the Use of**  
**the Exposure Button**



**Connecting the**  
**Coil-cord Hand**  
**Switch—**  
**Operator Panel**  
**Located on**  
**Control Unit**

1. Remove the screw holding the front cover of the Control Unit in place. Place the screw in a safe location for later use.
2. Remove the front cover.
3. Cut out the notch on the base of the Control Unit front cover.
4. Route both the Operator Panel cable and the coil-cord hand switch through the hole in the bottom of the Control Unit front cover.
5. Place a loop of the coil cord into the notch.
6. Carefully reassemble the Control Unit front cover, keeping the coil-cord in the notch. Secure the front cover with the screw that was removed in step 1.
7. Locate the Operator Panel in the top portion of the shipping carton.
8. Connect the coil-cord hand switch to the left plug socket (as viewed from the back) on the bottom of the Operator Panel. Connect the short white cable to the right plug socket.
9. Carefully dress the two cables back into the front cover of the Control Unit.
10. Snap the Operator Panel into place on the front cover of the Control Unit.
11. Mount the bracket for the coil-cord hand switch in a convenient location.
12. Stow the coil-cord hand switch.

**Connecting the**  
**Coil-cord Hand**  
**Switch—**  
**Operator Panel in**  
**Remote Location**

1. Route the cable from the coil-cord hand switch through the hole in the wall mounting plate.
2. Place a loop of the coil cord into the notch.
3. Locate the Operator Panel in the top portion of the shipping carton.
4. Connect the coil-cord hand switch to the left plug socket (as viewed from the back) on the bottom of the Operator Panel. Connect the control cable to the right plug socket.
5. Carefully dress the two cables back into the wall.
6. Snap the Operator Panel into place on the wall mounting plate.
7. Mount the bracket for the coil-cord hand switch in a convenient location.
8. Stow the coil-cord hand switch.

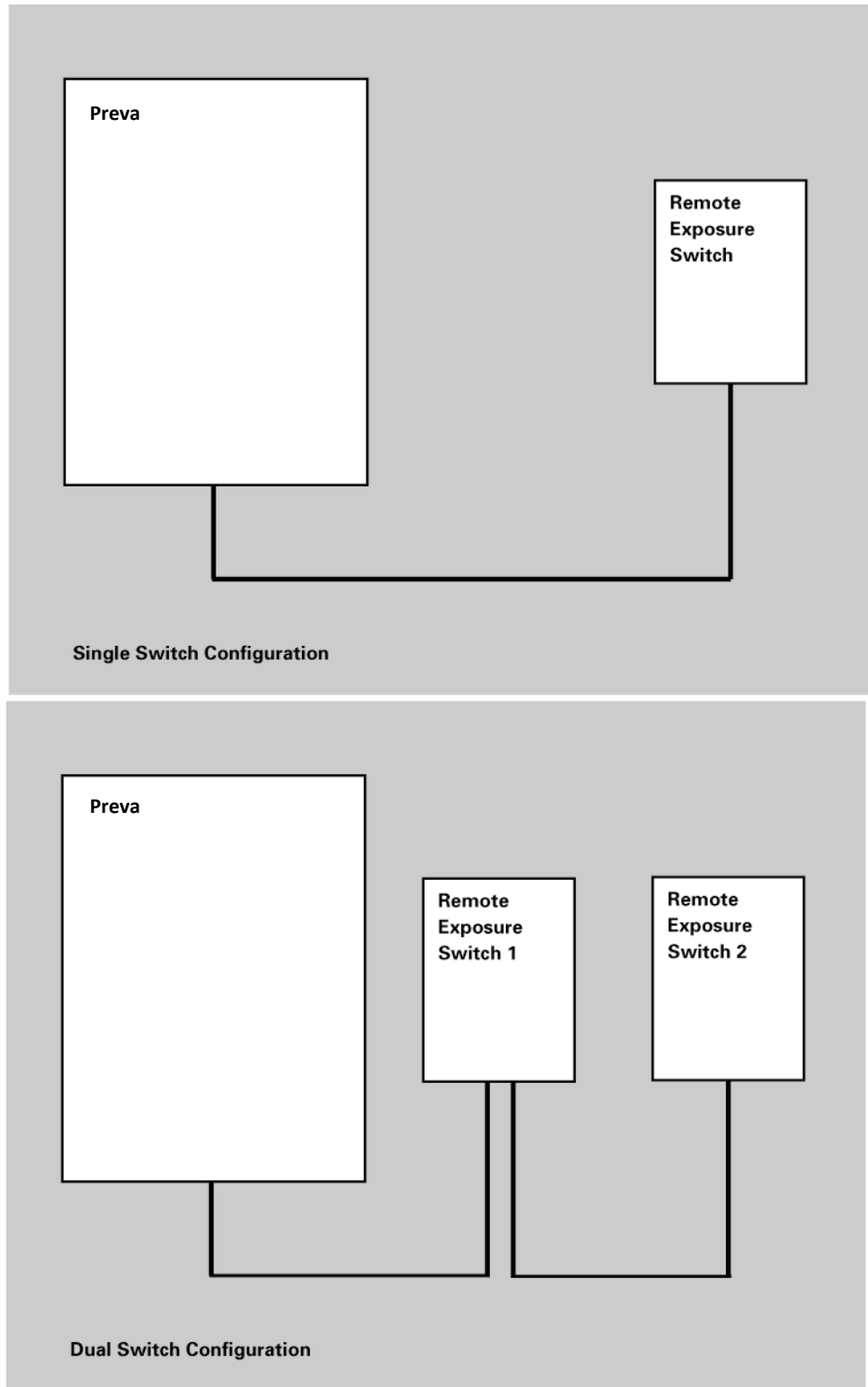
## Installing the Remote Exposure Station (30-A2044)

The Remote Exposure Station is an option for the Preva that allows the operator to make the exposure from a fixed location remote from the main unit. As shown in *Figure 42*, a single switch can be used, or two switches can be used in series or in parallel. Two switches in series will require both switches to be pressed simultaneously to make an exposure. If two switches are used in parallel, only one needs to be pressed to make an exposure.

### Tools

The following tools are required to install the switch:

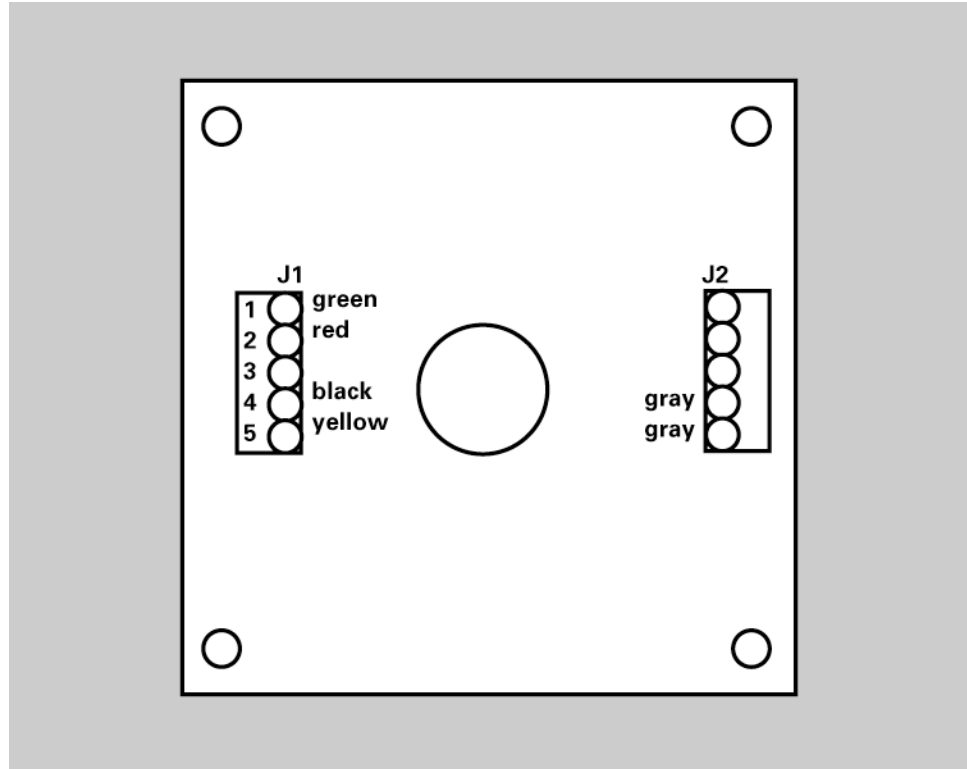
- Phillips screwdriver
- Flat-blade screwdriver
- Telephone cable stripper (for dual switch configuration only)
- Wire stripper (for dual switch configuration only)



**Figure 42**  
**Remote Switch**  
**Configurations**

## Installing the Single Switch

1. Route the cable for the Remote Exposure Switch from the Preva mounting location to the Remote Exposure Switch mounting location. This can be done through conduit or on the wall surface. For either method, a 2" x 4" junction box should exist where the Remote Exposure Switch is to be mounted.
2. Thread the cable end with the handset connector through the opening in the wall mount cover from the inside and connect it to the Operator Panel. If the cable is routed on the surface of the wall, it should enter the wall mount cover through the notch on the left of the power switch.
3. Connect the cable conductors on the opposite end of the cable to terminal block J1 on the PCB in the switch enclosure as shown in *Figure 43*.



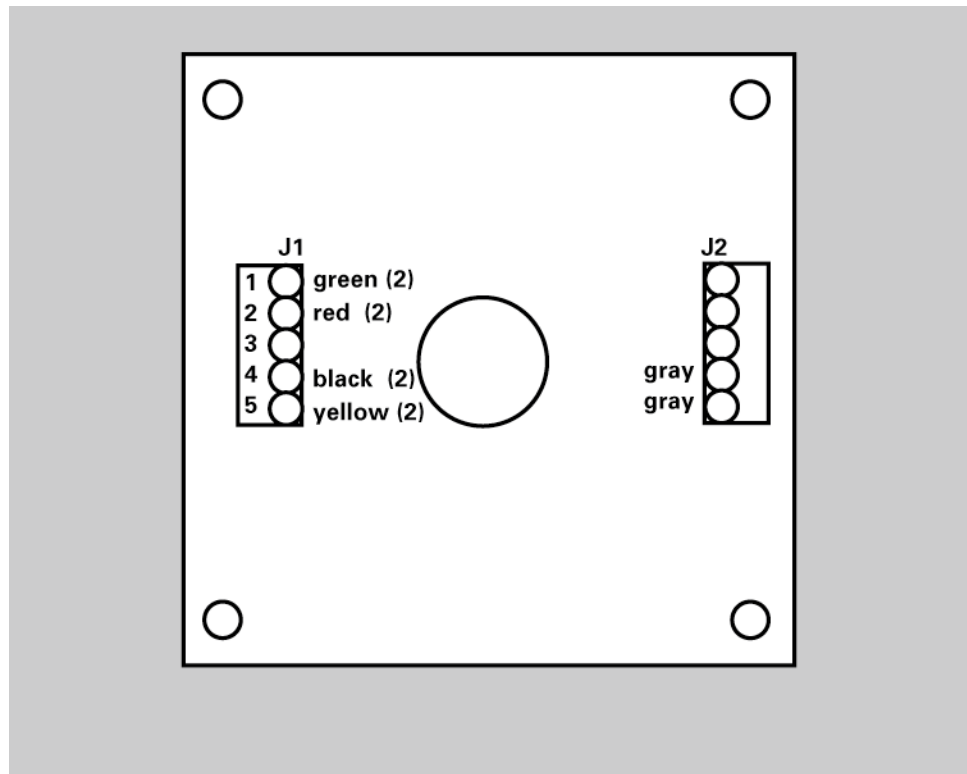
**Figure 43**  
**Single Switch**  
**Configuration**

4. Make sure the two gray wires from the pushbutton switch are connected to terminals 1 and 2 of J2.
5. Screw the inner section of the enclosure to the junction box using the two screws provided. If the cable is routed on the surface of the wall, make sure it sits in the notch on the bottom of the enclosure. Confirm that no wires are being pinched between the junction box and the enclosure.
6. Hook the outer section of the enclosure and fasten the two pieces at the bottom with the 6-32 x 5/16" screw.

## Installing the Dual Switch

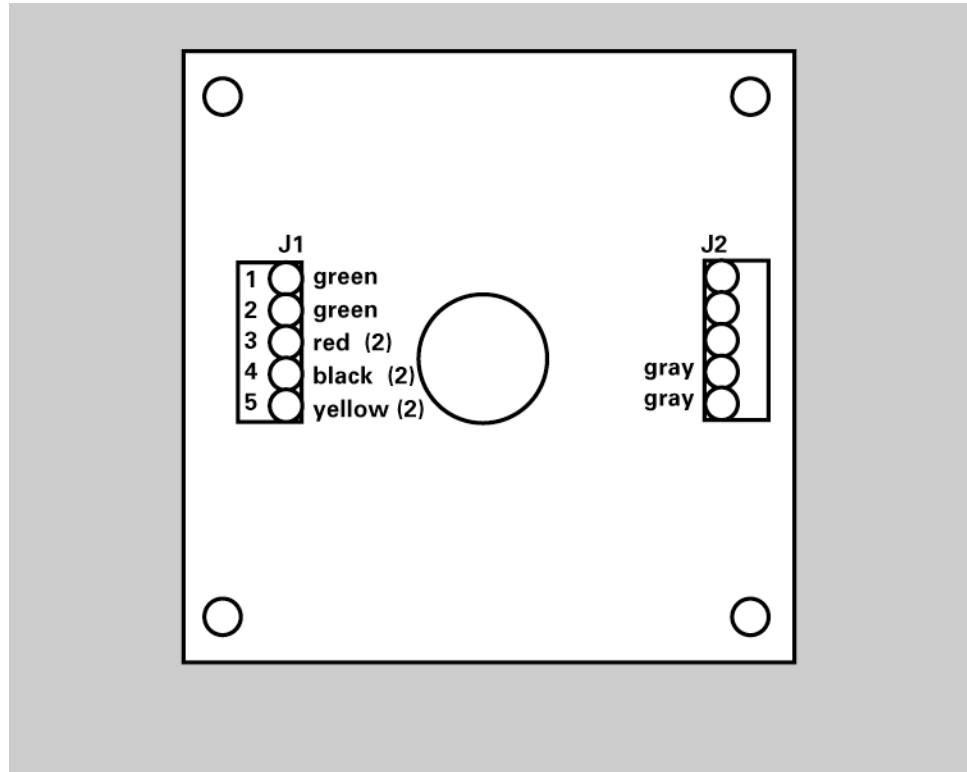
**Note:** This configuration uses two cables. One connects the Preva to the first switch and the other connects the first switch to the second switch.

1. Route one cable from the Preva to the first switch location either through conduit or on the surface of the wall.
2. Route the other cable from the first switch location to the second switch location either through conduit or on the surface of the wall.
3. Thread the first cable end with the handset connector through the opening in the wall mount cover from the inside and connect it to the Operator Panel. If the cable is routed on the surface of the wall, it should enter the wall mount cover through the notch on the left of the power switch.
4. For a parallel connection, connect the cable conductors of both cables to terminal block J1 on the PCB of switch enclosures #1 as shown in *Figure 44*. The (2) indicates that two green wires will join together in terminal 1 of J1, etc. For a series connection, connect the wires as shown in *Figure 45*.



**Figure 44**  
**Parallel Switch**  
**Configuration**



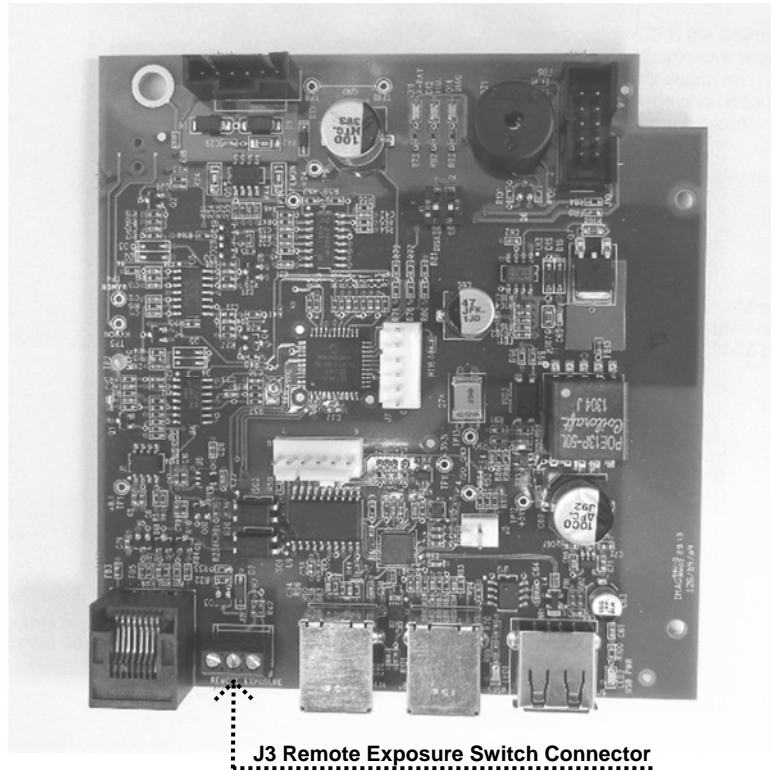


**Figure 45**  
**Series Switch**  
**Configuration**

5. Make sure the two gray wires from the pushbutton switch are connected to terminals 1 and 2 of J2.
6. Screw the inner section of enclosure #1 to the junction box using the two screws provided. If the cable is routed on the surface of the wall, make sure it sits in the notch on the bottom of the enclosure. Confirm that no wires are being pinched between the junction box and the enclosure.
7. Hook the outer section of the enclosure onto the inner section at the top. Push the wires all the way into the enclosure and fasten the two pieces at the bottom with the 6-32 x 5/16-inch screw.
8. Cut the handset connector from the end of the cable that will connect to switch enclosure #2 and strip about 1 1/2-inch of the white jacket.
9. Strip 1/4-inch of insulation from each of the conductors.
10. Connect the cable conductors to terminal block J1 on the PCB of switch enclosure #2 as shown in *Figure 43* (the same as the single switch configuration).
11. Make sure the two gray wires from the pushbutton switch are connected to terminals 1 and 2 of J2.
12. Screw the inner section of enclosure #2 to the junction box using the two screws provided. If the cable is routed on the surface of the wall, make sure it sits in the notch on the bottom of the enclosure. Confirm that no wires are being pinched between the junction box and the enclosure.
13. Hook the outer section of the enclosure onto the inner section at the top. Push the wires all the way into the enclosure and fasten the two pieces at the bottom with the 6-32 x 5/16-inch screw.

## Connecting to a Generic 2 Wire Remote Exposure Switch

To use a generic 2-wire switch, connect the wires to the terminal block J3 Remote Exposure Switch Connector on the Power Supply Control Board 30-08160, as shown in *Figure 46*.



**Figure 46**  
**Installing the**  
**Remote Exposure**  
**Switch**

## Installing the 12 Inch [30 CM] Cone (30-A2200)

The Preva Dental X-ray System is factory set for use with the standard supplied 8 inch [20 cm] Cone. The 12 inch [30 cm] Cone (30-A2200) is recommended when using parallel film positioning techniques. Using the longer cone requires longer exposure times. See the System Configuration section of this manual on page 61 or setting the system to use the longer cone.

## System Configuration

### System Configuration Mode

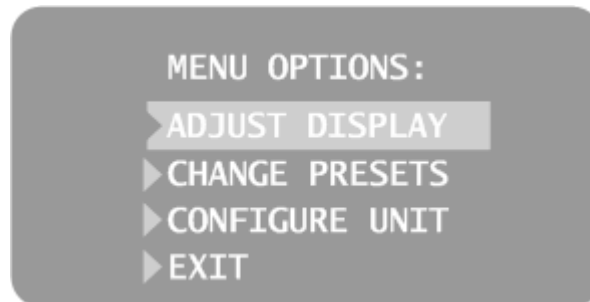
#### About System Configuration Mode

The Preva Dental X-ray System has a software-driven system configuration mode. When the Preva is in system configuration mode, you can perform the following procedures:

- Adjusting the Display
- Changing the Pre-programmed Exposure Settings
- Change the Cone Size
- Showing the Current System Configuration
- Display Diagnostic Data

#### Using System Configuration Mode

1. To enter system configuration mode, press the Tooth Selection and Patient Size Selection buttons on the Operator Panel simultaneously for 5 seconds. The display shows the Main System Configuration menu, as shown in *Figure 47*, and the Ready Indicator blinks.
2. To select menu items while in system configuration mode, use the up and down arrows to highlight a menu option. Then use the right arrow button as an “Enter” button to select the highlighted option. When changing presets, the right arrow button is also used to select the technique factor.
3. After selecting a menu option, use the up and down arrows to increase or decrease values.



**Figure 47**  
**Main System**  
**Configuration Menu**

## Adjusting the Display

### Adjusting Contrast

### Reversing the Image

The Preva Dental X-ray System allows the operator to adjust the display image.

1. From the Main System Configuration menu, *Figure 47*, select ADJUST DISPLAY. You will see the Display Options menu shown in *Figure 48*.
  2. Selecting EXIT returns the display to the Main System Configuration menu.
1. Select ADJUST CONTRAST from the menu. You will see the Progeny® logo.
  2. Use the up and down arrows to increase or decrease the contrast between the menu text and the display background.
  3. Press the right arrow to save your settings.
1. Select REVERSE IMAGE from the menu. The text and display background colors will be swapped.
  2. Press the right arrow to save your settings.



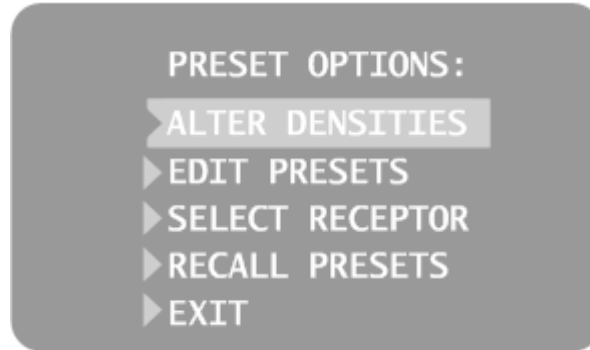
**Figure 48**  
**Display Options**  
**Menu**

## Changing Pre-programmed Exposure Settings

	<p>The Preva Dental X-ray System allows the operator to increase or decrease image density for all presets for a receptor simultaneously or to change each of the technique factors for a preset individually. You can also restore factory default settings. For charts of the factory default settings, refer to Factory Default Exposure Settings on page 18 in the Preva User manual.</p> <p><b>Note:</b> If the 12" [30 cm] cone is going to be used, configure the Preva for use with the 12" cone before changing preprogrammed exposure settings. Configuring the Preva for use with the 12" cone will reset exposure settings to the default settings used with the 12" cone.</p>
<b>Displaying the Change Presets Menu</b>	<ol style="list-style-type: none"><li>1. From the Main System Configuration menu, <i>Figure 47</i>, select CHANGE PRESETS. You will see the Preset Options menu shown in <i>Figure 49</i>.</li><li>2. Selecting EXIT returns the display to the Main System Configuration menu.</li></ol>
<b>Changing All Receptor Settings Globally</b>	<ol style="list-style-type: none"><li>1. Select ALTER DENSITIES from the Preset Options menu. The first Image Receptor Type illuminates. The display shows the selected Image Receptor Type and current density.</li><li>2. Using the Image Receptor Type button, select the image receptor to adjust.</li><li>3. Use the up and down arrow buttons to specify a percentage by which densities will be increased or decreased for the selected receptor. Densities can be increased in steps of 25% and decreased in steps of 20%.</li><li>4. Press the right arrow to save your settings.</li></ol>
<b>Preprogramming to Digital Sensors</b>	<ol style="list-style-type: none"><li>1. Energize the system.</li><li>2. Press the Tooth Selection and Patient Size Selection buttons for five full seconds.</li><li>3. Select CHANGE PRESETS from the Menu Options screen.</li><li>4. Select SELECT RECEPTOR from the Preset Options menu.</li><li>5. Press the up or down button to highlight the sensor or phosphor plate to change, and press Enter.</li><li>6. Select YES or NO on the Verification screen.</li><li>7. Exit the Preset Options menu.</li></ol>
<b>Changing Presets Individually</b>	<ol style="list-style-type: none"><li>1. Select EDIT PRESETS from the Preset Options menu. The display notifies you that you are entering Edit Preset Mode, and Tooth Size, Image Receptor Type and Patient Size are illuminated.</li><li>2. Use the Tooth Selection, Image Receptor Type and Patient Size Selection buttons to select the preset to change. The display shows the current values for the preset.</li><li>3. Use the right arrow button to display the technique factor to change.</li><li>4. Use the up and down arrow buttons to set the value for the selected technique factor and preset.</li><li>5. Repeat steps 2-4 to change additional presets.</li><li>6. When you have completed all changes, press the Tooth Selection and Patient Size Selection buttons simultaneously for 5 seconds to record the change.</li></ol>

## Recall Presets

1. To return all presets to factory defaults, select RECALL PRESETS from the Preset Options menu. The menu will ask you to confirm your choice.
2. Select YES using the up arrow button and return all presets to factory default settings. Selecting YES will erase any custom presets that have been set up.
3. Select NO using the down arrow button and retain current presets.

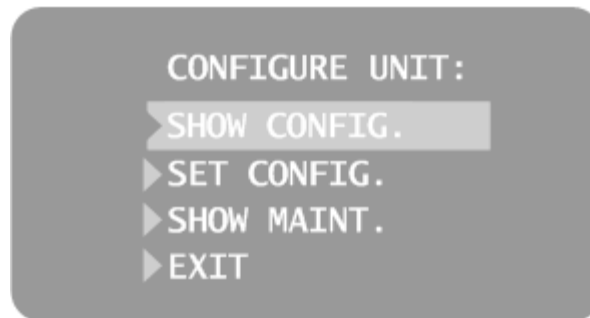


**Figure 49**  
**Preset Options**  
**Menu**

## Showing Current System Configuration

The Preva Dental X-ray System displays the current system configuration. This display is informational only.

1. From the Main System Configuration menu, Figure 47, select CONFIGURE UNIT. You will see the Configuration menu shown in *Figure 50*.
2. Select SHOW CONFIG. The display will show:
  - Current software version
  - Cone size
  - Diagnostic mode on or off
3. Press any button on the Operator Panel to return to the Configuration menu.



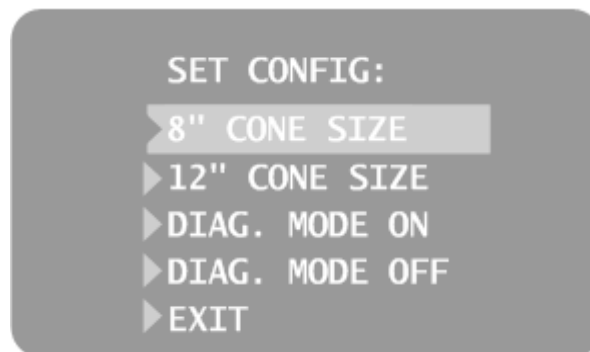
**Figure 50**  
**Configuration Menu**

## Changing the Cone Size

### Using a 12 inch [30 CM] Cone

Selecting SET CONFIG from the Configuration menu, *Figure 50*, displays the Set Configuration menu, *Figure 51*, with options to change the cone size. The Preva Dental X-ray System is preset for use with the standard supplied 8" [20 cm] Cone. The 12" [30 cm] Cone (30-A2033) is available. Using the longer Cone requires longer exposure times, which the Preva automatically selects when you change the Cone size in the Set Configuration menu.

1. From the Main System Configuration menu, *Figure 47*, select CONFIGURE UNIT. You will see the Configuration menu shown in *Figure 50*.
2. Select SET CONFIG. You will see the Set Configuration menu, shown in *Figure 51*.
3. From the Set Configuration menu, use the up and down arrows to highlight the 12" CONE SIZE.
4. Press the right arrow button to select the 12" Cone. The display warns you that selecting the 12" Cone will override custom presets with the default factory settings for the 12" Cone.
5. Using the up arrow, select YES to install presets for the 12" Cone.



**Figure 51**  
**Set Configuration**  
**Menu**

## Diagnostic Mode

### About Diagnostic Mode

The Preva Dental X-ray System has a diagnostic mode in which you can display a summary of maintenance data or display feedback values after each exposure.

### Showing the Maintenance Summary

1. From the Main System Configuration menu, *Figure 47*, select CONFIGURE UNIT. You will see the Configuration menu shown in *Figure 50*.
2. Select SET CONFIG. You will see the Set Configuration menu, shown in *Figure 51*.
3. To display a summary of maintenance data, highlight select SHOW MAINT. The following maintenance data are displayed:
  - Total KJ (kilojoules—total system heat on the X-ray tube)
  - Exposure Count
  - Reboots (power up cycles)
  - OT Counts (over-threshold counts)
4. Press any button on the Operator Panel to return to the Configuration menu.

### Showing Feedback Values After an Exposure

If you take an X-ray while in diagnostic mode, the display shows feedback values for that exposure. Until you exit diagnostic mode, the display will continue to show feedback values after each exposure.

1. From the Main System Configuration menu, *Figure 47*, select CONFIGURE UNIT. You will see the Configuration menu shown in *Figure 50*.
2. Select SET CONFIG. You will see the Set Configuration menu, shown in *Figure 51*.
3. From the Set Configuration menu, use the up and down arrows to highlight DIAG MODE ON. Press the right arrow button to turn on diagnostic mode.
4. Exit System Configuration mode by highlighting and selecting EXIT in the Configuration and Main menus.
5. Make an exposure. The display will show the following feedback values:
  - kV
  - mA
  - Filament current
6. Press any button on the Operator Panel to clear the feedback values from the display.
7. To exit diagnostic mode, press the Tooth Selection and Patient Size Selection buttons simultaneously for 5 seconds to display the Main System Configuration menu. From the Main menu, highlight and select CONFIGURE UNIT. Then highlight and select SET CONFIG. On the Set Configuration menu, highlight and select DIAG MODE OFF.

**Note:** Feedback values are approximate.



## Calibration

Devices with firmware revision of 5.0 and below will require calibration of the tube current. Please contact Midmark at the number listed in the manual for calibration instructions.

### Calibrating kV

Occasionally, it may be necessary to calibrate kilovoltage (kV). Approximate mA and kV levels can be observed using the Diagnostic Mode feature of the Preva system. If the kV needs calibration, follow these steps.

1. Energize the system.
2. Press and hold the Tooth Selector switch and the Patient Size Selector switch for five seconds.
3. Select the SET CONFIG option. You will see the Set Configuration menu, *Figure 51*.
4. Press the down arrow to highlight the DIAGNOSTIC MODE ON option, and press Enter. You will see the Configure Unit menu, *Figure 50*.
5. Press the down arrow to highlight the Exit option, and press Enter. This displays the Menu Option screen, *Figure 47*.
6. Press the down arrow to highlight the Exit option, and press Enter. This returns the display to operational mode.
7. Press Enter to select the kV to be adjusted.
8. Press Enter to highlight the time to be adjusted.
9. Observe normal radiation protection procedures in preparation for the following steps.
10. Make an exposure.
11. Observe the feedback values.

### Adjusting kV during Calibration

To adjust kV:

1. Press the Up switch to activate the Adjust feature. This displays the Current kV Modulation Level screen.
2. Press the Up or Down switch while observing the Counts indicator.
3. Adjust the Counts in small increments.
4. Press Enter to exit and return to operational mode.
5. Make an exposure and observe the feedback.
6. Repeat steps 1 – 5 until the desired kV level is reached.

### Deactivating the Calibration Session

Once completed, it is necessary to deactivate the calibration session.

1. Press and hold the Tooth Selector switch and the Patient Size Selector switch for five seconds. You will see the Menu Options screen, *Figure 47*.
2. Press the down arrow to highlight the CONFIGURE UNIT option, and press Enter. This displays the Configure Unit menu, *Figure 50*.
3. Press the down arrow to highlight the Set Configuration option, and press Enter. You will see the Set Configuration menu, *Figure 51*.
4. Press the down arrow to highlight the Diagnostic Mode Off option, and press Enter. This displays the Configure Unit screen.
5. Press the down arrow to highlight the Exit option, and press Enter. This displays the Menu Option screen.
6. Press the down arrow to highlight the Exit option and press Enter. This returns the system to operational mode.

## Troubleshooting

### Electrical Performance Issues

#### Contact Support

Questions should be directed to Midmark Technical Support:

Phone: 800-MIDMARK  
Fax: 847-415-9801  
imagingtechsupport@midmark.com

#### General Information

##### Test Equipment

Electrical measurements require specific meter test probes. Use small test clips, such as Pomona Electronics Minigrabber Test Clip Model 6248 or Radio Shack Mini-Hook Adapters catalog # 270-334, or the equivalent.

##### Replacement Parts

- |                               |          |
|-------------------------------|----------|
| • Kit, Power Supply Board     | 30-A2155 |
| • Logic Board                 | 30-08160 |
| • Operator Panel Board        | 30-08054 |
| • 25 foot Communication Cable | E1-13003 |
| • 6 inch Communication Cable  | E1-13004 |
| • Rocker Switch               | E1-19026 |
| • Yoke Cable Assembly         | 30-08071 |
| • Tubehead Assembly           | 30-A1027 |
| • Ribbon Cable Assembly       | 30-08072 |

##### Note

- If you replace the Operator Panel Board 30-08054, you must re-program any customized technique factors, as explained in the System Configuration section of this manual.
- If you replace the Logic Board 30-08160 or the Tubehead, and the firmware revision is 5.0 or less, you must recalibrate the system. Please contact Midmark Technical Support for instructions.

#### **CAUTION!**

**The Preva system has the capacity to store electrical energy during operation and after the system has been turned off.**

- **The Preva system will store energy for approximately three minutes after removal from power lines.**
- **Before attempting service within the system, observe the green LED “D11” of the Power Supply Board. Illumination represents the presence of stored energy.**
- **As an added safety practice, it is recommended to measure for the presence of DC voltage across TP8 and TP5 of the Power Supply Board.**

**No Operator  
Display but  
Power Switch is  
ON**

**Your Responsibilities As An Installer And Service Engineer**

**Verification of machine performance after installation** must be performed according to the guidelines identified in the “System Function Checklist” which can be found in the User Manual or, the Installation and Service Manual on page 51.

**Verification of machine performance after maintenance or repair** must be performed according to the guidelines identified in the “System Function Checklist” and the calibration instructions which can be found in the Installation and Service Manual on page 51.

1. On the Power Supply Board 30-08041, check for the presence of 100 to 230 volts AC at J4, the Input Power Terminal Strip, as shown in *Figure 52*. If power is absent, check that the Preva is connected to line power.
2. On the Power Supply Board 30-08041, measure incoming power at J3, the Line Switch Connector, as shown in *Figure 52*. Positions 2 and 4 carry the line voltage before the Line Switch, and positions 1 and 3 carry the line voltage after the Line Switch. Voltage at the input side of the switch, but not at the output, requires replacement of the Line Switch E1-19000.
3. Inspect the condition of the communication cable between the Logic Board and the Operator Panel. Midmark includes two communication cables with each Preva system. Should the installed communication cable be suspect, temporarily substitute the other cable as a test tool.
4. If the power switch is on and there is no operator display and a faint buzzing sound is also detected, check the ribbon cable installed between the Power Supply Board and the Logic Board. If the cable is not properly seated, reinsert it. If it is damaged, replace the cable.
5. On the Logic Board, measure voltages at TP1 (+8.1V) and TP9 (+24V). Use TP8 or TP10 as Common Return. If any of these voltages are not present after power is applied, next check voltages on the Power Supply Board.
6. On the Power Supply Board, use TP2, as a common test point, and check TP1 +24 volts DC and TP3 8.1 volts DC, as shown in *Figure 52*. Then use TP5 as the common return to check TP4 for the presence of +12 volts DC. Should any of these voltages not be present, replace the Power Supply Board. If each voltage is present, inspect the condition of the ribbon cable between the Power Supply Board and the Logic Board. If the cable is undamaged and seated properly, replace the Logic Board.
7. If the power supply voltages are present, and the ribbon cable and communication cable are found acceptable, open the Operator Panel case and measure for the presence of +5 volts DC across TP1 and TP4 of the Operator Panel Board, as shown in *Figure 54*. Absence of this voltage indicates the need to reconfirm the power supply voltages and communication cable. Presence of the voltage requires the replacement of the Operator Panel Board.

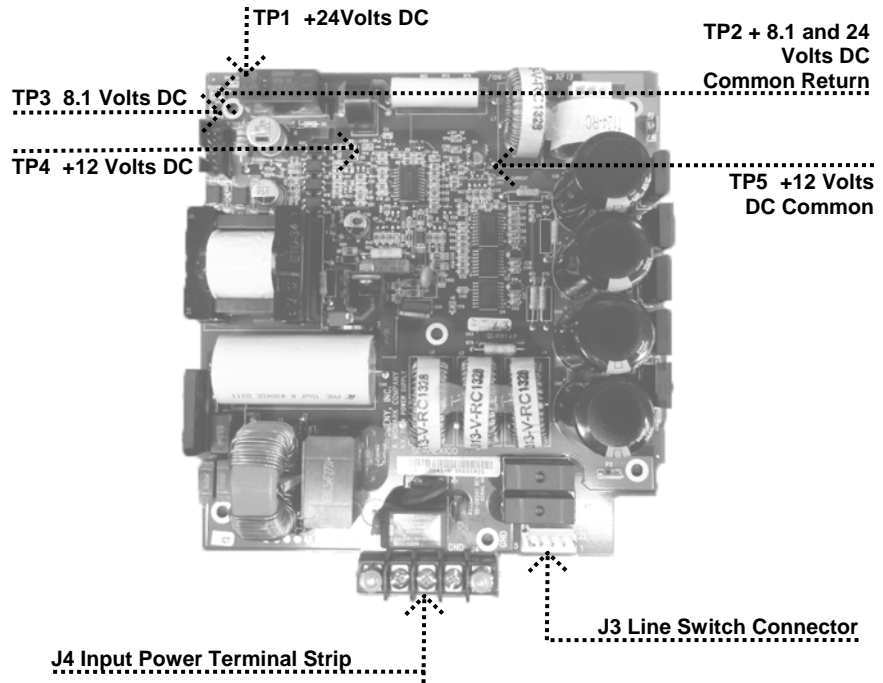


Figure 52  
Power Supply  
Board 30-08041

Use TP8 or TP10 for Common Return  
when measuring DC voltages.....

TP9 +2.  
.....

TP1 +8.  
.....

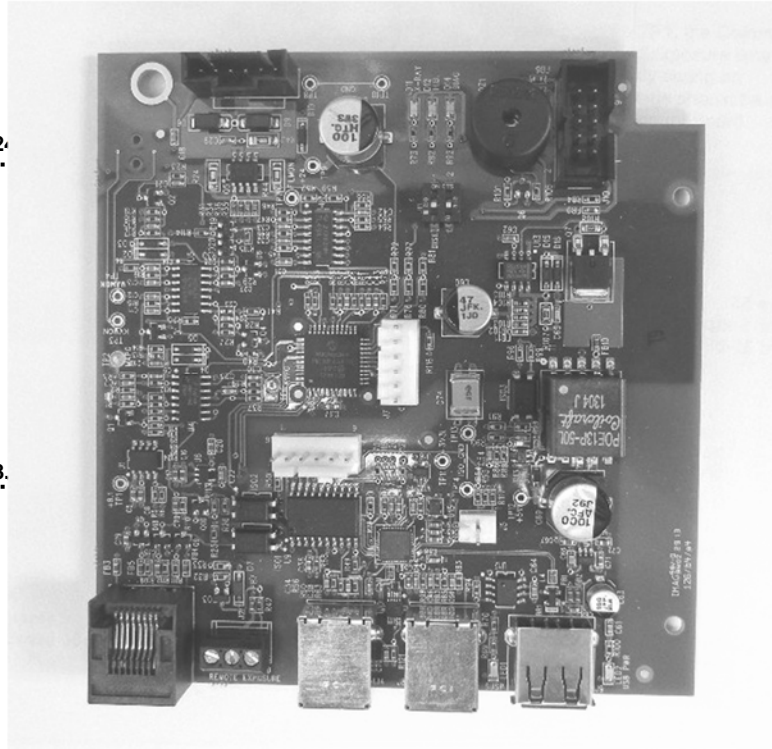


Figure 53  
Logic Board  
30-08160

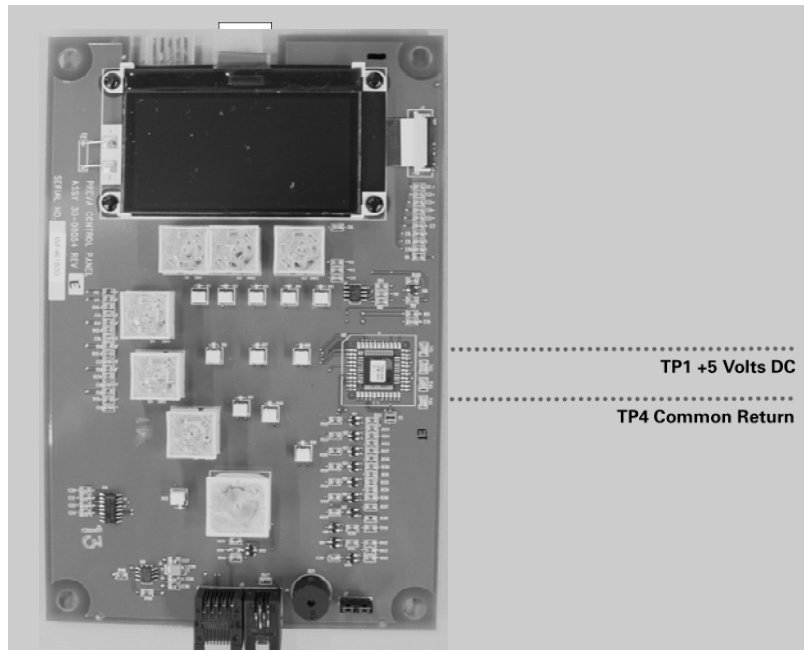


Figure 54  
Operator Panel  
Board 30-08054

**Light or Dark  
X-ray Images**

1. Adjust the selected exposure time, kilovoltage or tube current to produce an acceptable image. If necessary, reprogram the techniques factors, as explained in the System Configuration section of this manual.
2. Verify the kilovoltage and tube current during an exposure using the diagnostic mode, as explained in the System Configuration section of this manual. Alternatively, you may employ a non-invasive meter to evaluate kilovoltage and exposure time.
3. Inspect the condition of the remaining imaging chain components such as the film, chemistry and processor, or the condition of the X-ray sensor and computer.
4. Check for pulsing output with fluorescent screen. If this is occurring, replace the Logic Board.
5. Light image can be caused by the Logic Board. This is characterized by a short pulse of exposure as viewed with a fluorescent screen. Replace the Logic Board.
6. Full fluorescence with light image may require adjustment of the preprogrammed techniques.

**At Power up, the  
Operator Display  
Stops at "Preva"**

Replace the operator display board.

**At Power Up,  
Continuous Beep,  
Backlit Display,  
No Display  
Characters, No  
Ready Light,  
Power Supplies  
OK**

Replace the Operator Display Board [30-08054] or the Logic Board [30-08160], or both.

**At Power Up,  
Continuous Beep  
with Normal  
Display**

Replace the Logic Board [30-08160].

**At Power Up,  
Buzzing Noise is  
Heard**

Replace the Logic Board [30-08160].

**X-ray Indicator,  
No Exposure  
Termination, No  
Radiation  
Produced**

1. Check if both audible indicators operate. Check the Operator Panel first, and check the Logic Board second.
2. If only the Operator Panel indicator works, check if diode “D2” on the Power Supply Board and “D11” on the Logic Board illuminate during the exposure request.
3. If “D2” and “D11” do not illuminate, this indicates that the “X-ray backup” conductors in the CAT 5 communication cable are open.
4. Connect a substitute communication cable to test for this condition.
5. If the symptom persists, contact Technical Support.

**Display Shows  
“Error – Serial  
Communications”**

If the ribbon cable is open between the Logic and Power Supply Boards, replace the cable.

**Display Shows  
“Pre-termination  
Error”, Early  
Exposure Release  
Determined Not to  
be the Cause**

This error can be caused by a high voltage breakdown in the head and is characterized by a snapping or popping noise within the Tubehead.

1. Inspect the condition of the feedback cable.
2. Inspect the condition of the communication cable.
3. If used, inspect the remote exposure switch wiring for a loose connection.
4. Refer to the High Voltage Breakdown information in the Troubleshooting section for detailed instructions.

**All X-ray  
Indicators, But No  
Voltage Measured  
at J1 on the  
Power Supply  
Board**

Replace the Power Supply Board [30-08041].

**Very Short  
Exposures,  
Regardless of  
Selected  
Exposure Time**

This condition will exist if the kV or mA produced is out of tolerance. To address this issue:

1. Inspect the condition of the high voltage circuit by operating the Preva in the diagnostic mode. Confirm incorrect kV or mA.
2. Inspect the Preva’s internal horizontal and articulated arm wiring. Repair as necessary.
3. If wiring is intact, and the firmware revision is 5.0 or less, attempt system recalibration. If greater, replace the Logic PCB Assy (30-08160).

4. If calibration cannot be achieved, the problem may require replacement of the tubehead assembly. Contact Midmark technical support for further assistance.
5. Check if D14 "DIAG" LED (Logic Board) is on. If so, check that DIP Switch #2 (J11, Logic Board) is in the correct position for the brand of X-ray tube in the unit. The label on the tubehead will indicate either Toshiba or Kailong. DIP Switch #2 should be in the OFF position for Toshiba, ON for Kailong.



**No X-ray  
Produced but  
Exposure  
Indicators  
Detected**

When no X-ray is produced, the Preva may still operate the exposure indicators. The procedure to troubleshoot a no X-ray condition depends on which exposure indicators are detected.

1. Activate diagnostic mode, as explained in the System Configuration section of this manual.
2. Take an exposure.
3. Follow the appropriate procedure below:
  - If no kV is produced, go to the procedure “No kV Produced”.
  - If no mA is produced, go to the procedure “No mA Produced”.
  - If no “I” is produced, go to the procedure “No (I) Filament Produced”.

**No kV Produced**

1. On the Power Supply Board, observe that the power supply indicator D11 +350volts DC is illuminated, as shown in *Figure 55*. Illumination represents proper stored energy for an exposure. If this indicator is not illuminated, it will be necessary to replace this board.
2. On the Logic Board, measure voltages at TP1 (+8.1V) and TP9 (+24V). Use TP8 or TP10 as Common Return. If any of these voltages are not present after power is applied, next check voltages on the Power Supply Board.
3. On the Power Supply Board, use TP2 as a common test point to check TP1 +24 volts DC and TP3 8.1 volts DC. Then use TP5 as the common return to check TP4 for the presence of +12 volts DC, as shown in *Figure 55*. Should any of these voltages not be present, replace the Power Supply Board. If each voltage is present, check other voltages on the Logic Board.
4. On the Logic Board, measure between TP8 or TP10, the Common Return and, TP6, kV Program. This voltage should be between 3 and 4 volts DC. If this voltage is not present, replace the Logic Board. If this voltage is correct, inspect the condition of the ribbon cable between the Power Supply Board and the Logic Board. If the cable is undamaged and seated properly, replace the Logic Board.
5. Check the condition of the cables between the Control Unit and the Tubehead assembly. If no X-ray occurs and no errors are displayed, the problem may lie within the conductors of the white connector (which is primary power to the Tubehead Assembly). If no X-ray occurs and the attempt is accompanied by a “snap” sound, the problem may lie with the conductors of the black connector (which is transmitting the feedback signals). Connections for this cable begin with controls at J1 of the Power Supply Board and J3 of the Logic Board. As shown in *Figure 57*, an internal set of connections will be accessed below the distal side of the horizontal arm and at the inside top of the Tubehead Yoke. The final set of connections is accessed by removing the Pivot Cap located at the attachment point of the Tubehead to the Yoke.
6. If D11 on the Power Supply Board is illuminated, power supplies are in order, and the cable connections are correct, place an AC voltmeter across the Tubehead connector J1 (white connector) on the black and white conductors, request an exposure time of at least 1.5 seconds, and measure the resulting voltage during the exposure. Presence of 130 volts AC will require the replacement of the Tubehead Assembly. Absence of 130 volts AC will require re-inspection of the interconnect cables for open conductors.

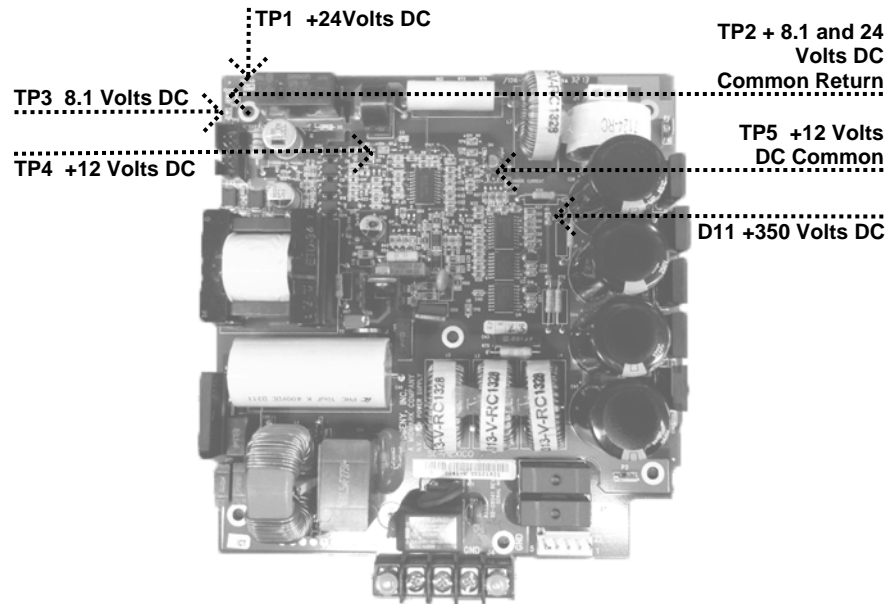


Figure 55  
Power Supply  
Board 30-08041

Use TP8 or TP10 for Common Return  
when measuring DC voltages.....

TP9 +2

TP6 kV I

TP1 +8

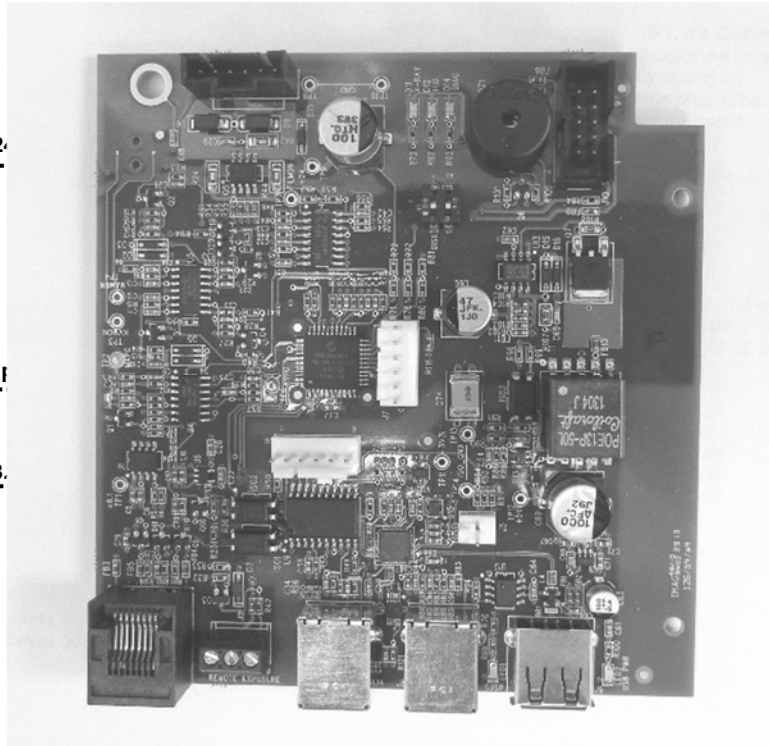


Figure 56  
Logic Board  
30-08160

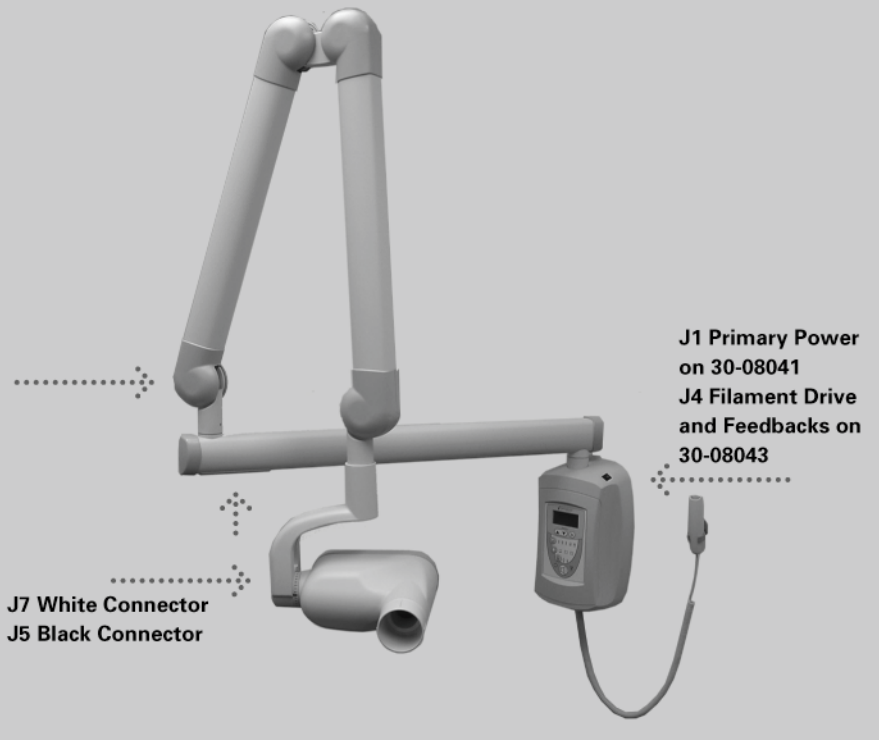


Figure 57  
Interconnect Cable  
Locations

**No mA  
Produced**

1. On the Logic Board, measure voltages at TP1 (+8.1V) and TP9 (+24V). Use TP8 or TP10 as Common Return. If any of these voltages are not present after power is applied, next check voltages on the Power Supply Board.
2. On the Power Supply Board, use TP2 as a common test point to check TP1 +24 volts DC and TP3 8.1 volts DC. Then use TP5 as the common return to check TP4 for the presence of +12 volts DC, as shown in *Figure 59*. Should any of these voltages not be present, replace the Power Supply Board. If these voltages are correct, next check voltages on the Logic Board.
3. On the Logic Board, measure between TP8 or TP10, the Common Return, and TP2, mA Program. This voltage should be between 1 and 2 volts DC. If this voltage is not correct, replace the Logic Board.
4. If this voltage is correct, select 1.5 seconds of exposure time, measure across pin 1 and pin 2 of the Logic Board at the connector J3. During exposures, this value should be 24 volts AC. Also measure across pin 2 and pin 3 of J3. This value should be 24 volts AC. If either voltage is missing, replace the Logic Board.
5. If these voltages are present, measure for the same values at the Tubehead Assembly at the connector J5 (black) on the blue and gray conductors and the blue and brown conductors. If the voltages are not present, inspect the inter-connect cables between the control and Tubehead Assembly. Connections for this cable begin with controls at J1 of the Power Supply Board and J3 of the Logic Board. As shown in *Figure 57*, an internal set of connections will be accessed below the distal side of the horizontal arm and at the inside top of the Tubehead Yoke. The final set of connections is accessed by removing the Pivot Cap located at the attachment point of the Tubehead to the Yoke.
6. If the voltages are present, replace the Tubehead Assembly.

J3 Cable Connector

Use TP8 or TP10 for Common Return  
when measuring DC voltages.

TP9 +24

TP2 mA Pt

TP1 +8

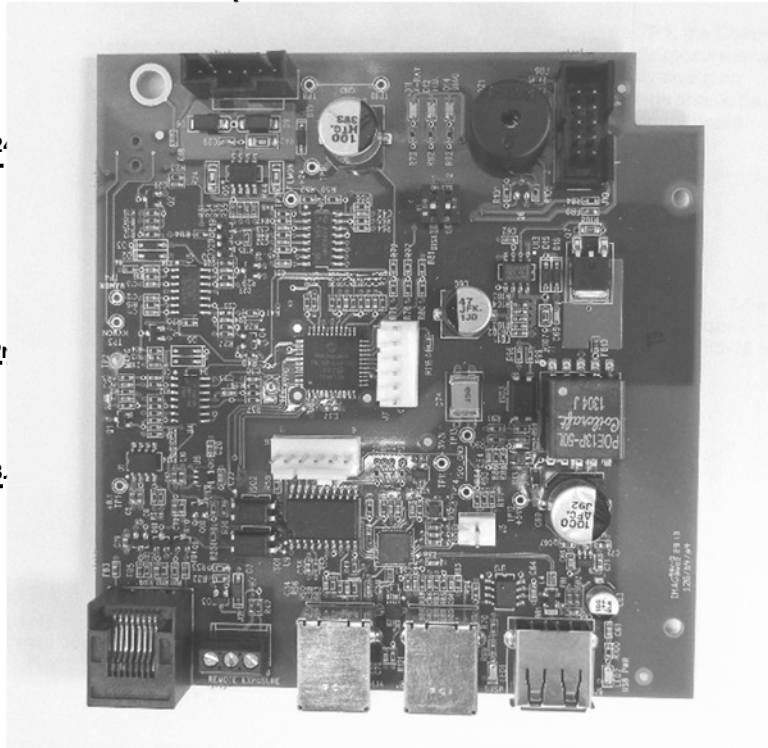


Figure 58  
Logic Board  
30-08160

TP9 24Volts DC

TP3 8.1 Volts DC

TP4 +12 Volts DC

TP2 + 8.1 and 24 Volts DC  
Common Return

TP5 +12 Volts  
DC Common

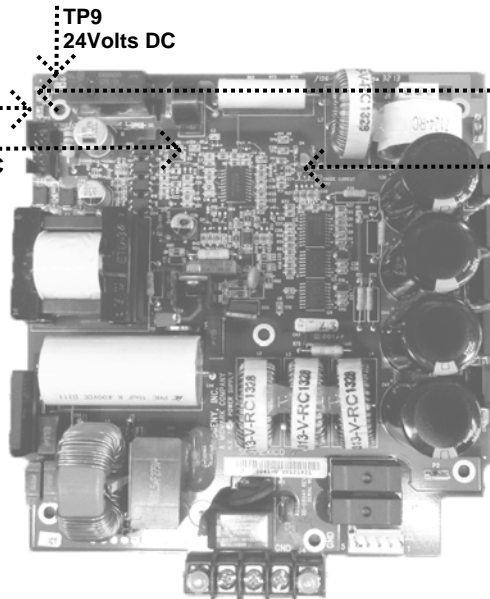


Figure 59  
Power Supply  
Board 30-08041

### No (I) Filament Produced

1. On the Logic Board, measure voltages at TP1 (+8.1V) and TP9 (+24V). Use TP8 or TP10 as Common Return. If any of these voltages are not present after power is applied, next check voltages on the Power Supply Board.
2. On the Power Supply Board, *Figure 61*, use TP2 as a common test point to check TP1 +24 volts DC and TP3 8.1 volts DC. Then, use TP5 as the common return to check TP4 for the presence of +12 volts DC, as shown in *Figure 60*. Should any of these voltages not be present, replace the Power Supply Board.

Use TP8 or TP10 for Common Return  
when measuring DC voltages.....

TP9 +24V  
.....

TP1 +8.1V  
.....

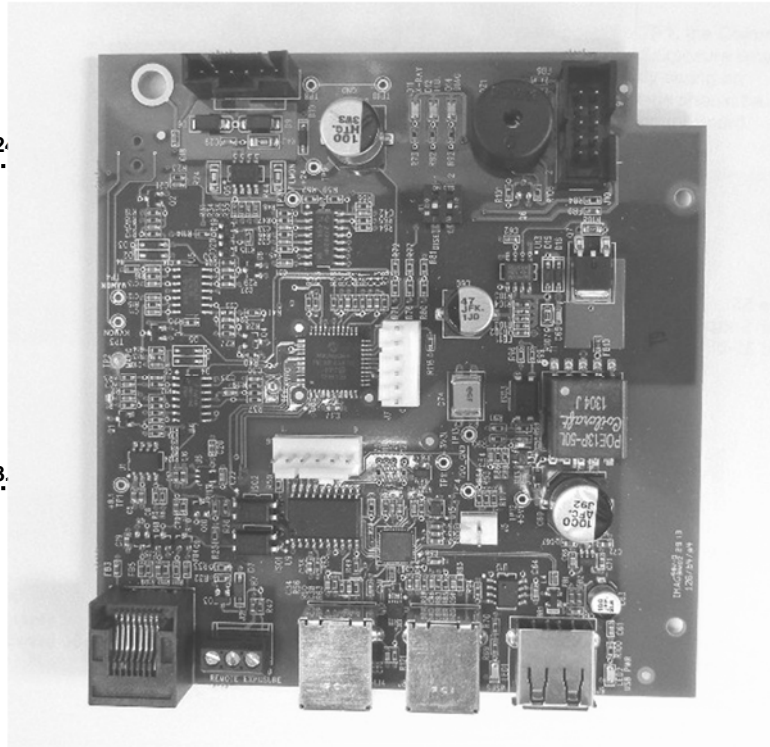
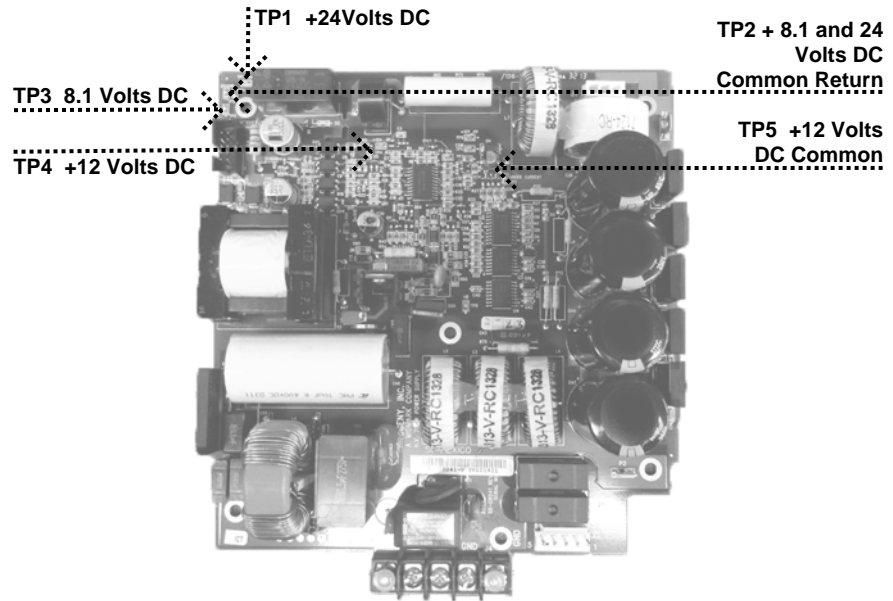


Figure 60  
Logic Board  
30-08160

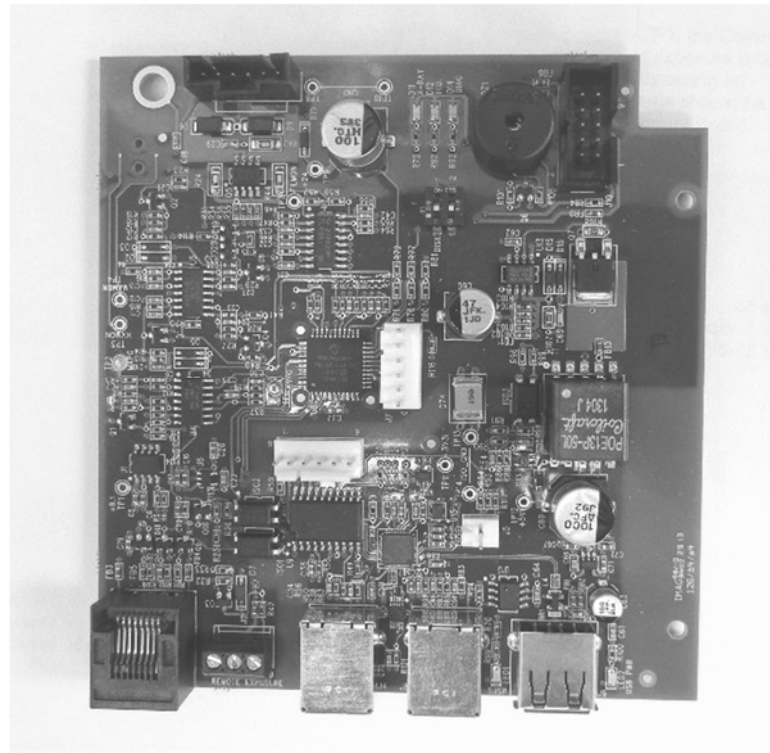


**Figure 61**  
**Power Supply**  
**Board 30-08041**

## No X-ray Produced and No Audible Exposure Indicators

Two different audible exposure indicators are employed within the Preva system. One indicator is embedded in the Operator Panel and will initiate when any exposure switch is pressed. The second audible indicator initiates when the Logic Board begins the exposure sequence. During normal operation, first the Operator Panel indicator will sound followed shortly thereafter by the Logic Board indicator. It is important to recognize the sequence for troubleshooting purposes.

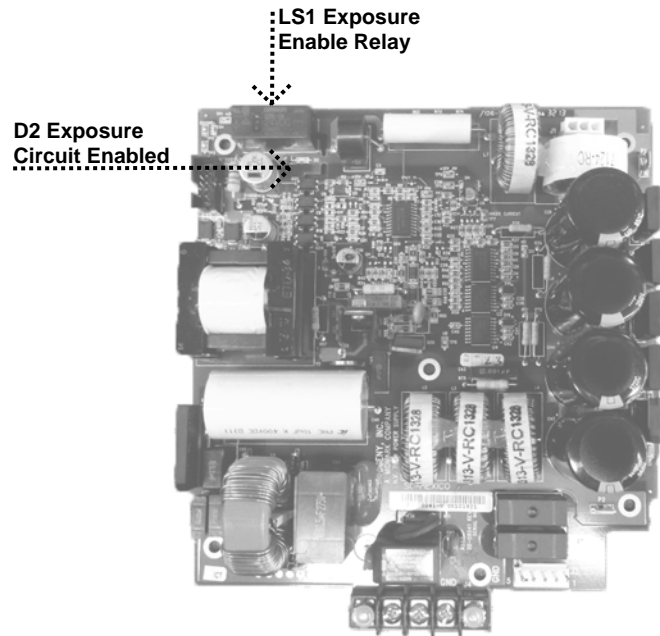
1. If the Operator Panel indicator does not sound, inspect the condition of any remote exposure switches. Substitution is the preferred method to test these switches, although a jumper wire can be applied across the contacts of J3, shown in *Figure 62*, on the Logic Board momentarily to simulate an exposure switch closure.
2. If the Operator Display indicator sounds, but the Logic Board indicator does not activate, observe LED D2 on the Power Supply Board, and listen for the relay LS1 to activate on this same board (*Figure 63*). LED D2 should illuminate during the exposure request. If not, inspect the condition of the ribbon cable between the Power Supply and the Logic Boards. If the ribbon cable is acceptable, replace the Logic Board.



**Figure 62**  
**Logic Board**  
**30-08160**

..... J2 Remote Exposure Switch Connector





**Figure 63**  
**Power Supply**  
**Board 30-08041**

## High-voltage Breakdown

High-voltage breakdown is characterized by a loud snap sound during an exposure request.

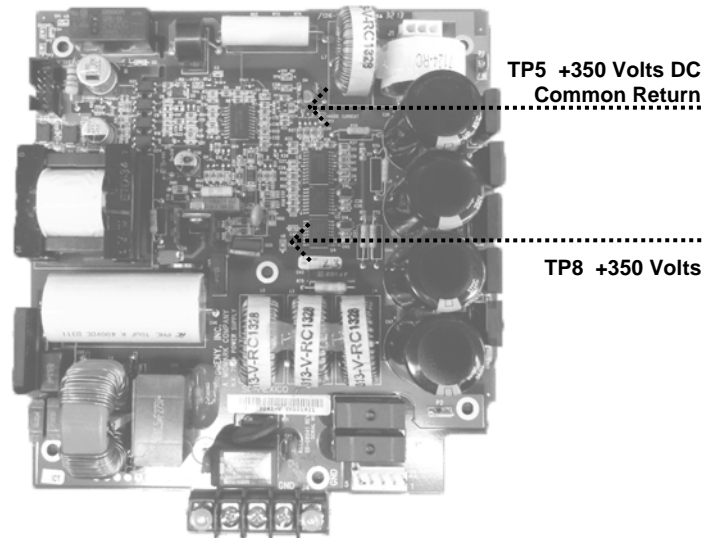
1. On the Power Supply Board, measure the voltage across TP5, the Common Return, and TP8, +350 volts DC, as shown in *Figure 64*. This voltage will be acceptable if measured between 330 and 390 volts DC. Values above or below this number indicate the need to replace the Power Supply Board.
2. If the voltage is correct, inspect the condition of the cabling between the Power Supply Board, Logic Board, and Tubehead Assembly.

### **CAUTION! High voltage present.**

Of particular importance are the conductors held by the black connectors. These conductors transmit the feedback values from the Tubehead Assembly and directly affect the control of power to the Tubehead Assembly.

Connections for this cable begin with controls at J1 of the Power Supply Board and J4 of the Logic Board. As shown in *Figure 57*, an internal set of connections will be accessed below the distal side of the horizontal arm and at the inside top of the Tubehead Yoke. The final set of connections is accessed by removing the Pivot Cap located at the attachment point of the Tubehead to the Yoke.

3. If the cabling is found acceptable, select 1.5 seconds of exposure time, and placing a DC voltmeter on TP8 or TP10, the Common Return on the Logic Board, measure the feedback values at TP4 mA Monitor and TP3 kV Monitor, as shown in *Figure 65*. Look for the following values:
  - TP4 – mA Monitor. This voltage should be between 1.5 and 3.5 volts DC during exposure attempts. The voltage should not oscillate between 1.5 and 3.5; instead the measurement should come to a specific value and stabilize. Oscillating values or absent values will indicate the need to replace the Tubehead Assembly.
4. TP3 – kV Monitor. This voltage should be between 3 and 4 volts DC during exposure attempts. The voltage should not oscillate between 3 and 4; instead the measurement should come to a specific value and stabilize. Oscillating values or absent values will indicate the need to replace the Tubehead Assembly. If the feedback voltages are present and stable, replace the Logic Board.



**Figure 64**  
**Power Supply**  
**Board 30-08041**

## Incorrect kV

At times, non-invasive measurement of an otherwise fully functional system indicates that kilovoltages may be incorrect. Kilovoltage [kV] is controlled by the microprocessor and is not adjustable. The Preva generates kilovoltage by first establishing a reference voltage and then comparing the feedback voltage to the reference. Follow these steps to establish proper operation of the kV controls

1. On the Logic Board, place a voltmeter on TP8 or TP10, the Common Return, and TP6, kV Program, as shown in *Figure 65*. Compare measurements to the following chart (volts DC).

	<b>60 kV</b>	<b>65 kV</b>	<b>70 kV</b>
<b>4 mA</b>	3.1	3.4	3.7
<b>5 mA</b>	3.2	3.5	3.75
<b>6 mA</b>	3.3	3.8	3.8
<b>7 mA</b>	3.4	3.7	NA

2. To evaluate the feedback voltages that represent the measured kV within the system, compare the observed values in the table below. To properly observe these values, select 1.5 seconds of exposure time and measure the DC voltages during the exposure only. This measurement is made across TP8 or TP10, the common return and TP3, the kV Monitor, as shown in *Figure 65*.

	<b>60 kV</b>	<b>65 kV</b>	<b>70 kV</b>
<b>4 mA</b>	3.1	3.4	3.7
<b>5 mA</b>	3.2	3.5	3.75
<b>6 mA</b>	3.3	3.6	3.8
<b>7 mA</b>	3.3	3.65	NA

Values that approximately match the above tables represent a correctly operating system. Other values may indicate that boards need to be replaced. Additional assistance can be obtained from Midmark Technical Support.

J3 Cable Connector

Use TP8 or TP10 for Common Return  
when measuring DC voltages.

TP4 mA M  
TP3 kV Mo  
TP2 mA P  
TP6 kV Pr

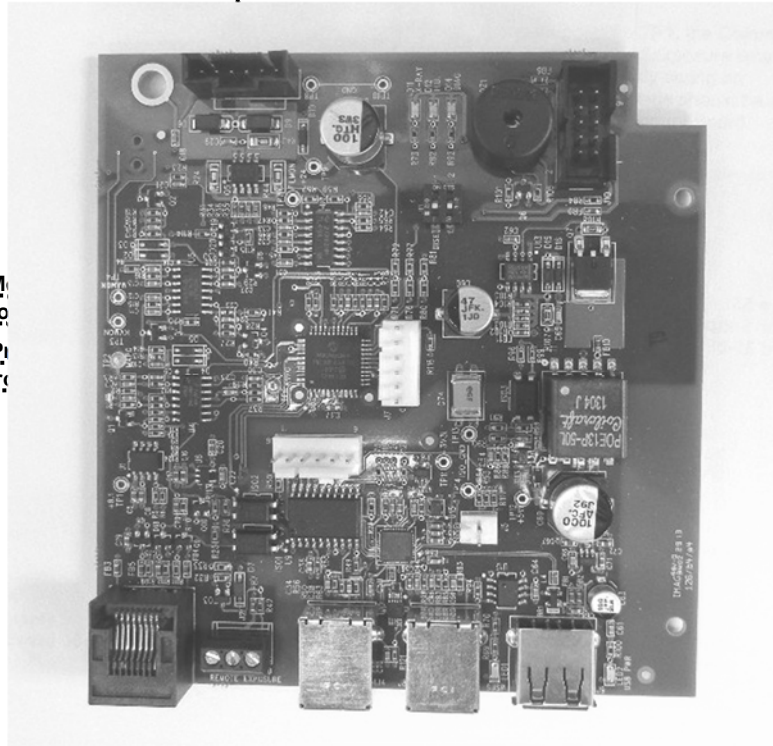


Figure 65  
Logic Board  
30-08160

## Incorrect mA

At times, various measurements of an otherwise fully functional system indicate that milliamperage may be incorrect. Milliamperage [mA] is controlled by the microprocessor and is not adjustable. The Preva generates milliamperage by first establishing a reference voltage and then comparing the feedback voltage to the reference. Follow these steps to establish proper operation of the mA controls.

1. On the Logic Board, place a voltmeter on TP8 or TP10, the Common Return and TP2, mA Program, as shown in *Figure 65*. Compare measurements to the following chart (volts DC).

	<b>60 kV</b>	<b>65 kV</b>	<b>70 kV</b>
<b>4 mA</b>	3.1	3.4	3.7
<b>5 mA</b>	3.2	3.5	3.75
<b>6 mA</b>	3.3	3.8	3.8
<b>7 mA</b>	3.4	3.7	NA

2. To evaluate the feedback voltages which represent the measured mA within the system, refer to the table below; select 1.5 seconds of exposure time and measure the DC voltages during the exposure only. This measurement is made across TP8 or TP10, the Common Return, and TP4, the mA Monitor, as shown in *Figure 65*.

	<b>Volts DC</b>
<b>4 mA</b>	2
<b>5 mA</b>	2.4
<b>6 mA</b>	2.9
<b>7 mA</b>	3.4

Values which approximately match the above tables represent a correctly operating system. Other values may indicate that boards need to be replaced. Further assistance can be obtained from Midmark Technical Support.

## Obtaining Technical Support

### Contact

Midmark Corporation  
675 Heathrow Dr.  
Lincolnshire, IL 60069  
Phone: 800-MIDMARK  
Fax: 847-415-9801

## Maintenance

### Preva Tubehead Removal Instructions

#### Overview

Tubeheads are shipped with the yoke cable assembly already premounted to the tubehead. This guide provides instructions for the installation technician on how to remove the original head, install the replacement tubehead and, how to calibrate the replacement tubehead.

**CAUTION: DO NOT REMOVE THE TUBEHEAD UNTIL THE ARTICULATING ARM ASSEMBLY HAS BEEN SECURED WITH THE PROVIDED CABLE TIE AND FOAM INSERT. THE SPRING TENSION IS ADJUSTED TO ACCOUNT FOR THE WEIGHT OF THE TUBEHEAD. THE ARTICUTING ARM WILL SPRING OPEN IF IT IS NOT SECURED AND CAN CAUSE SERIOUS INJURY.**

#### Models Affected

All Preva Dental X-rays

#### Required tools

Spanner wrench (30-T0055)  
Needle nose pliers  
Metric Allen wrenches  
#2 Phillips head screw driver  
#1 Small Phillips head screw driver  
Fluorescent screen (22-11467)

#### Instructions

1. The replacement head as received will have the yoke cable assembly pre attached.

**NOTE: Do not remove the yoke cable from the tubehead.**



Figure 66

2. Remove the cone from the head being replaced. The cone sits in the tubehead. Grab the cone firmly, pull and twist out in the same motion.



Figure 67

3. Install the cone in the replacement tubehead.



Figure 68

4. Remove the two Allen head screws from the yoke and remove the yoke cover.

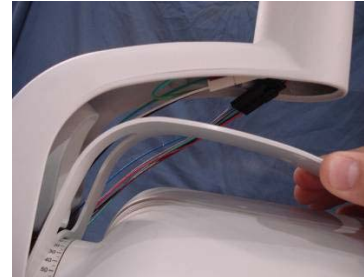
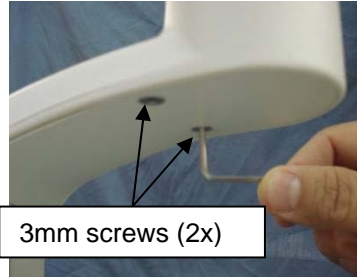


Figure 69

5. Unplug the black and white connector.

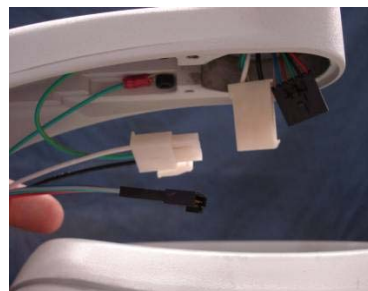
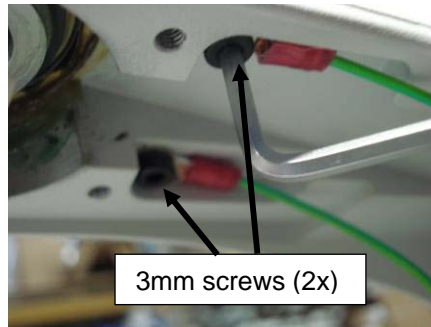


Figure 70



6. Remove the two Allen head screws that secure the two ground wires to the yoke. Take note of the position of each ground wire.



**Figure 71**

7. Remove the end cap from the side of the tubehead.



**Figure 72**

8. Remove the small Phillips head screw that holds the cable restraint.



**Figure 73**

9. Remove the larger Phillips head screw.



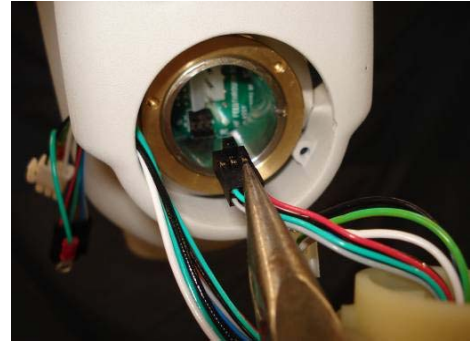
**Figure 74**

10. Remove the larger retaining ring by pulling it out with a pair of needle nose pliers.



**Figure 75**

11. Unplug the black and white connectors located inside the tubehead.



**Figure 76**

12. Secure the scissor arm with the provided cable tie and foam separator before removing both spanner rings.

**WARNING: DO NOT REMOVE THE TUBEHEAD UNTIL THIS STEP HAS BEEN COMPLETED. THE SPRING TENSION IS ADJUSTED TO INCLUDE THE WEIGHT OF THE TUBEHEAD. THE ARTICULATING ARM WILL SPRING OPEN IF IT IS NOT SECURED AND CAN CAUSE SERIOUS INJURY.**



Figure 77

13. Assemble the spanner wrench by threading the two leverage arms into the base of the spanner wrench.



Figure 78

14. Align the three pins on the spanner tool with the alignment holes in the brass spanner nut.

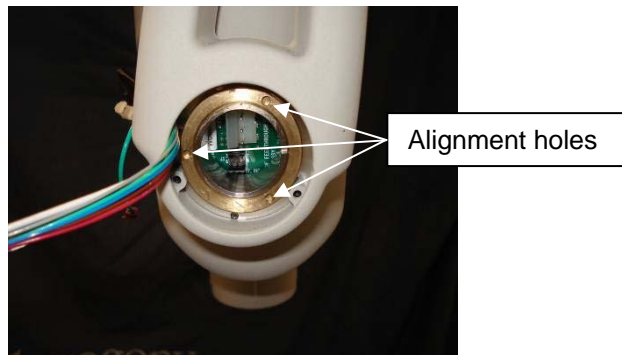


Figure 79

15. Break loose the spanner ring by turning the spanner wrench counter clockwise.



Figure 80

16. Repeat steps 14 & 15 to remove the second spanner ring.
17. Carefully remove the tubehead from the yoke.

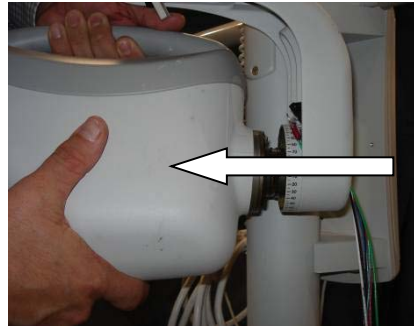


Figure 81

18. Remember to transfer the friction ring from the original tubehead to the new tubehead. The friction ring will either be on the shaft of the original tubehead or in the yoke assembly

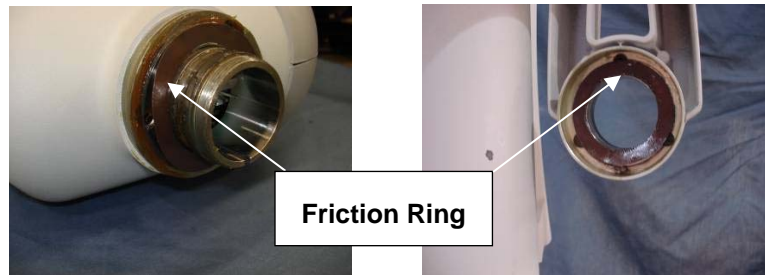


Figure 82

19. Feed the connectors and ground wires of the pre-assembled yoke cable assembly through the opening of the yoke collar.



Figure 83

20. Insert the tubehead into the yoke collar

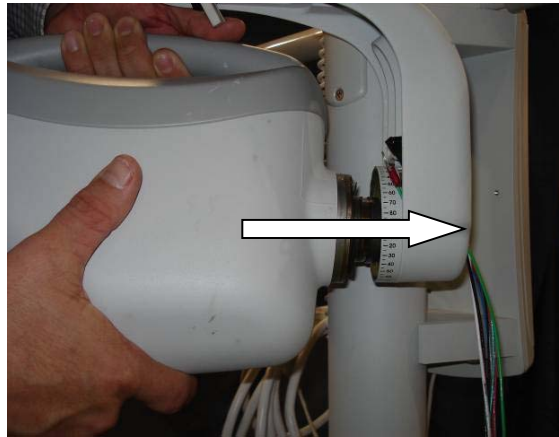


Figure 84

21. Feed the connectors and ground wire of the yoke cable through the first spanner nut.



Figure 85

22. Manually thread the spanner nut on the tubehead shaft. Insert a small screwdriver into one of the alignment holes to finish tightening the spanner ring.



Figure 86

23. Feed the connectors and ground wire of the yoke cable through the spanner wrench.



Figure 87

24. Align the three pins on the spanner wrench with the three holes in the spanner nut.

**NOTE: Take care not to pinch or cut any of the yoke cable assembly wires. Doing so will cause intermittent exposure or no exposures.**

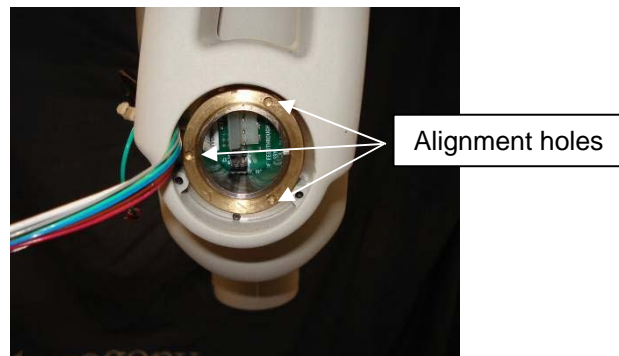


Figure 88

25. Tighten the spanner nut.
26. Carefully remove the spanner wrench.  
**NOTE: Take care not to damage the connectors.**
27. Repeat steps 21 through 26 for the second spanner nut.

28. Feed the black connector through the yoke collar.

**NOTE: Take care not to damage the connector.**

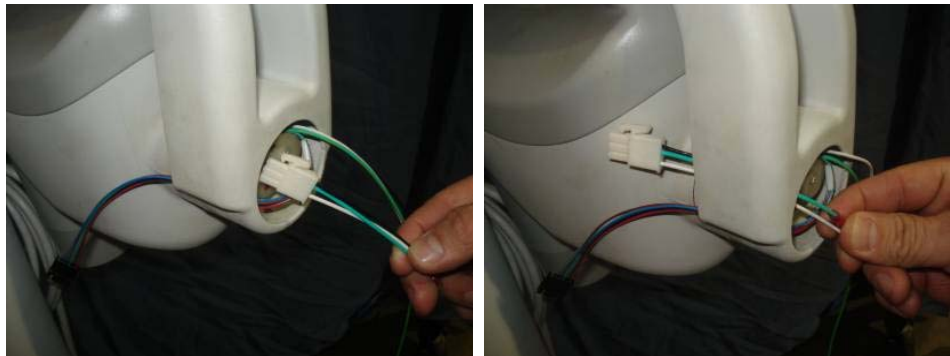
Figure 89



29. Feed the white connector through the yoke collar.

**NOTE: Take care not to damage the connector.**

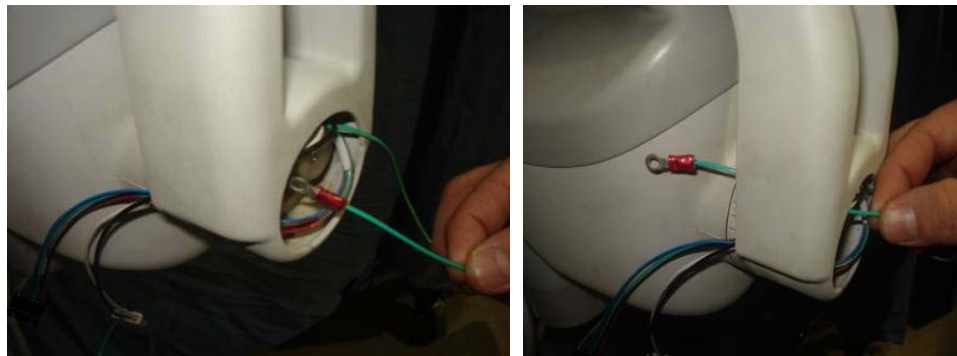
Figure 90



30. Feed the ground wire through the yoke collar.

**NOTE: Take care not to damage the connector.**

Figure 91



31. Re-attach the two ground cables that were removed in (Step6.)



Figure 92

32. Connect the black and white connectors that were disconnected in (Step 5.)

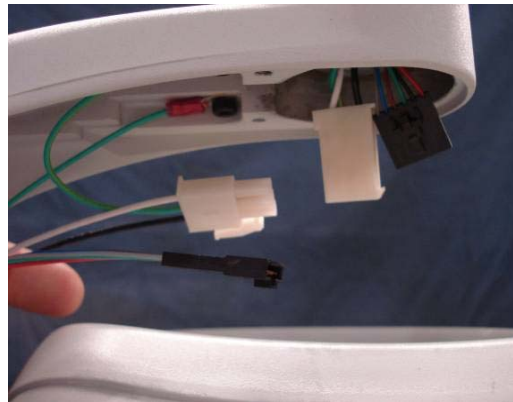


Figure 93

33. To ensure correct operation and to prevent damage to the yoke cable assembly perform the following steps:

33.1) Point the tubehead down.

33.2) Check that the large Phillips head screw is at the 9 o'clock position and that there is a natural loop in the cable harness.

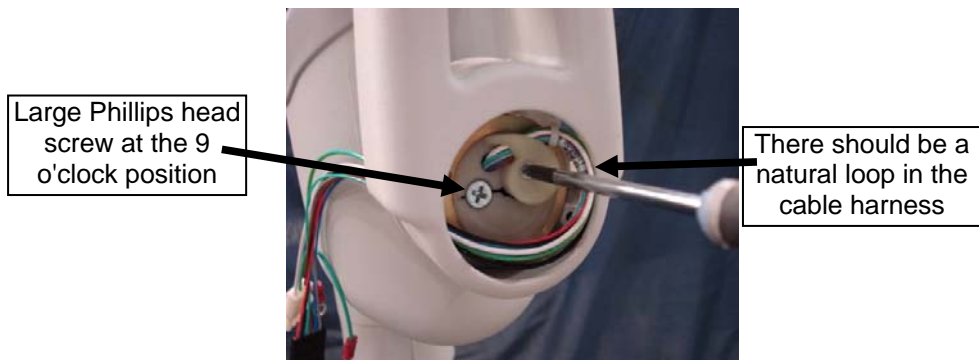


Figure 94



34. Mount the yoke cover that was removed in (Step 4)

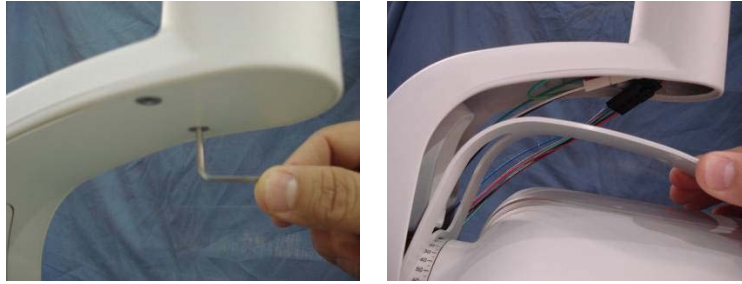


Figure 95

35. Check to ensure the wires are **not** binding when you rotate the tubehead completely clockwise or completely counter clockwise. The cabling should expand and contract cleanly and evenly without any binding.

36. Place the cap back on the tubehead.



Figure 96

37. Proceed with the automated calibration found on page 67 if Logic PCB firmware revision is 5.0 or lower.

## Mechanical Adjustments

### Determining the Necessary Adjustment

The balance and friction of the Articulating Arm and the friction of the Tubehead are initially set at the factory. During the installation process, check the balance and friction. When moving the Tubehead, the Articulating Arm should be steady in all positions and move before the Horizontal Arm.

**Note:** The mechanical adjustments should not be used to compensate for a system that is not properly leveled on the wall.

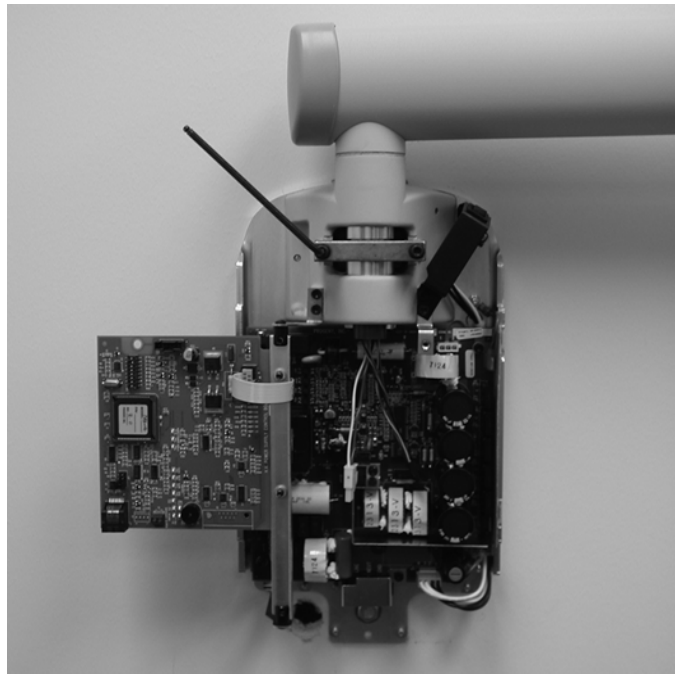
### Tubehead Movement

The movement of the Tubehead is set in the factory and cannot be adjusted.

### Horizontal Arm Adjustment

Note: If performing this adjustment as part of the initial installation of the Preva, omit steps 1-3.

1. Remove the screw from the Control Unit front cover.
2. Carefully remove the front cover.  
**Note:** If the Operator Panel is installed on the Control Unit, carefully keep the Operator Panel together with the front cover.
3. Unplug the cable connectors and set the front cover aside.
4. Locate the brake assembly at the top of the Control Unit. The brake assembly has a screw on either side of a clamping bar over the Horizontal Arm pivot post.
5. Using a 4 mm Allen wrench, as shown in *Figure 97*, tighten the screws equally to apply adequate braking to the pivot post so that Horizontal Arm begins to move after the Articulating Arm.
6. Replace and re-connect the front cover of the Control Unit. Replace the screw on the front cover.

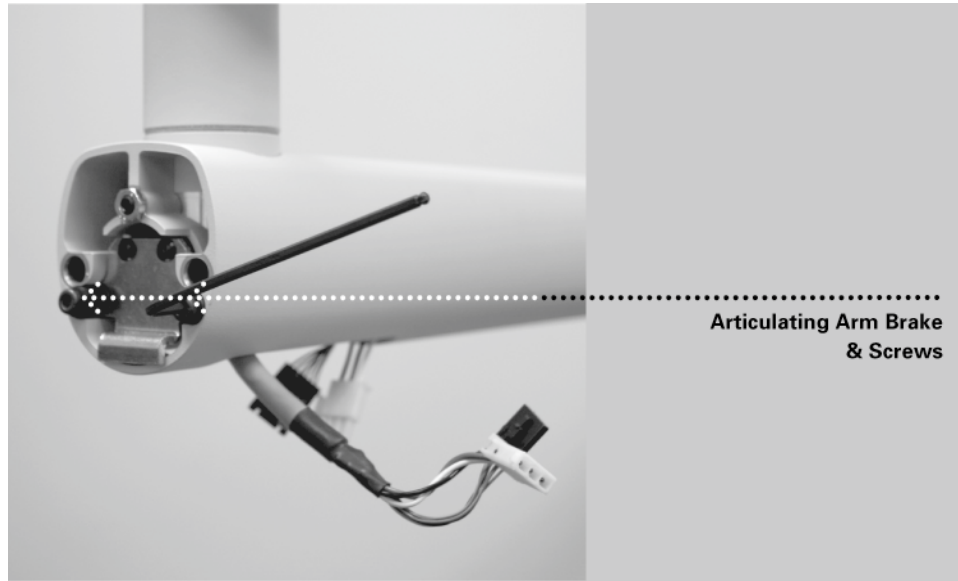


**Figure 97**  
Tightening the Brake

### Adjusting the Horizontal Arm Brake Assembly

Locate the friction assembly screws. Using a 3 mm Allen wrench, as shown in *Figure 98*, tighten or loosen screws as necessary to get proper movement without unwanted horizontal movement of the Articulating Arm.

**CAUTION!**  
**Do not attempt to adjust any other screws in the  
Horizontal Arm.**

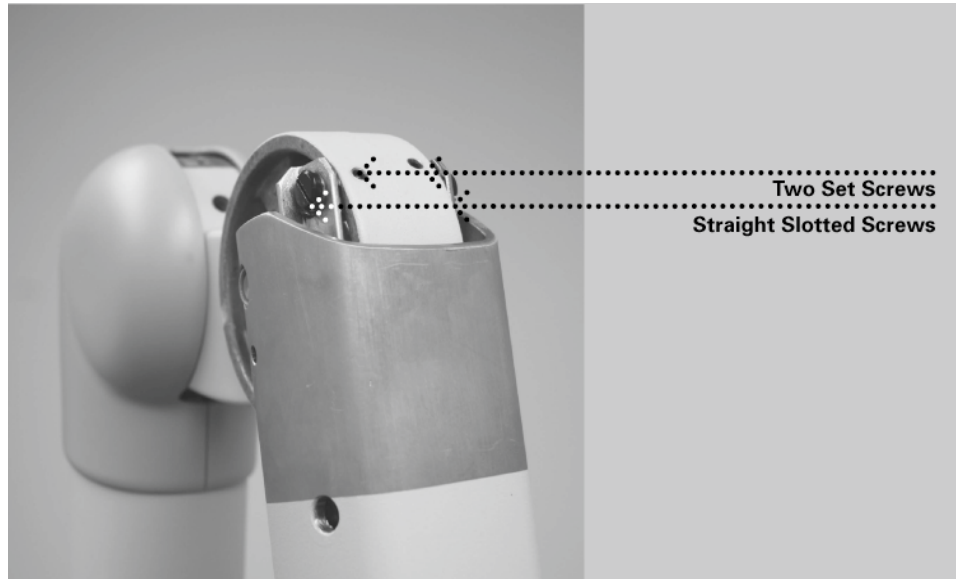


**Figure 98**  
**Adjusting the  
Articulating Arm  
Brake Assembly**

## Adjusting the Articulating Arm

Follow this procedure **ONLY** if the yoke assembly does not stop on its own and makes contact with the horizontal arm. Refer to *Figure 99* while following the procedures below.

1. Loosen the two set screws highlighted in *Figure 99*, but do not remove them completely.
2. Loosen the two straight-slotted screws highlighted in *Figure 99* (the figure shows only one of the two screws – the other is located on the opposite side of the arm), but do not remove them completely.
3. Move the articulating arm into the position where you want it to stop before it makes contact with the horizontal arm.
4. Tighten the two straight-slotted screws.
5. Tighten the two set screws.



**Figure 99**  
**Adjusting the**  
**Articulating Arm**

### Outside Articulating Arm Vertical Movement

1. Remove the plastic trim covers from the end of the Articulating Arm nearest to the Tubehead.
2. Position the Articulating Arm with the arm nearest the Tubehead fully upward.
3. Insert a 9" [23 cm] long 8 mm Allen wrench (T-handle) into the adjustment nut, as shown in *Figure 100*. Turning the wrench clockwise will cause the Control Unit side of the Articulating Arm to lift. Turning it counterclockwise will cause it to drop.
4. Adjust as necessary until the Control Unit side of the Articulating Arm no longer drifts.
5. Replace the plastic covers on the end of the Articulating Arm.



**Figure 100**  
Adjusting Vertical  
Movement of the  
Articulating Arm

### Control Unit Side of Articulating Arm Balance Adjustment

1. Remove the plastic covers at the top of the Articulating Arm.
2. Position the Articulating Arm at a 45-degree angle.
3. Place a 9" [23 cm] long 8 mm Allen wrench (T-handle) into the adjustment nut inside the Articulating Arm, as shown in *Figure 101*. Turning the wrench clockwise will cause the Control Unit side of the Articulating Arm to lift. Turning it counterclockwise will cause it to drop.
4. Adjust as necessary until the Control Unit side of the Articulating Arm no longer drifts.
5. Replace the plastic covers on top of the Articulating Arm.

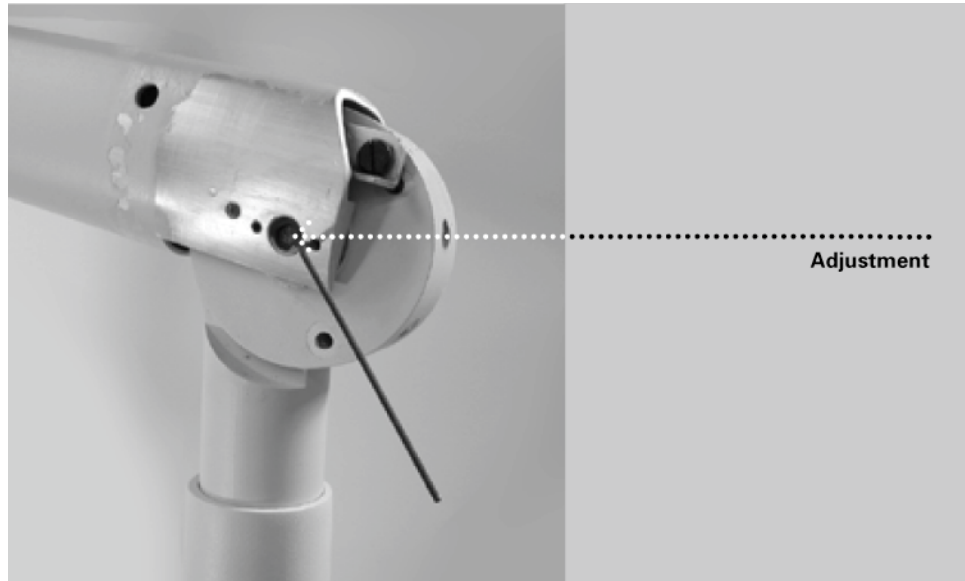


**Figure 101**  
Adjusting  
Articulating Arm  
Balance

## Articulating Arm Friction Adjustments

The Preva has four friction adjustment points located at the four pivot points of the Articulating Arm. These friction points can be adjusted to reduce or increase the force needed to position the Articulating Arm.






1. Remove the plastic covers on the Articulating Arm to reveal the adjustment points.
2. Using a 2 mm Allen wrench, as shown in *Figure 102*, tighten both screws evenly at each adjustment point until the movement of the Articulating Arm is as desired. Do not loosen adjustment points so far as to allow the Articulating Arm to drift.








**Figure 102**  
**Friction**  
**Adjustments**

## Preprogrammed Exposure Times

The tables below show the factory default exposure settings for each combination of Tooth, Image Receptor Type, and Patient Size on the Operator Panel. These exposure settings can be modified using the System Configuration mode. See the System Configuration section for details on page 61.

8-inch Cone [20 cm]																	
Setting		Progeny®		Schick		Dexis®		Kodak		Sirona		PSP		D Speed		E/F Speed	
		Adult	Child	Adult	Child	Adult	Child	Adult	Child	Adult	Child	Adult	Child	Adult	Child	Adult	Child
 Incisor	kV	60	60	65	65	60	60	65	65	60	60	60	60	60	60	60	60
	mA	7	7	7	7	7	7	7	7	7	7	7	7	7	7	7	7
	sec	0.125	0.064	0.080	0.050	0.125	0.064	0.080	0.050	0.080	0.064	0.160	0.080	0.320	0.160	0.160	0.080
 Bicuspid	kV	60	60	65	65	60	60	65	65	60	60	60	60	60	60	60	60
	mA	7	7	7	7	7	7	7	7	7	7	7	7	7	7	7	7
	sec	0.125	0.064	0.080	0.050	0.125	0.064	0.125	0.080	0.080	0.064	0.160	0.080	0.320	0.160	0.160	0.080
 Bitewing	kV	60	60	65	65	60	60	65	65	60	60	60	60	60	60	60	60
	mA	7	7	7	7	7	7	7	7	7	7	7	7	7	7	7	7
	sec	0.160	0.080	0.100	0.064	0.160	0.080	0.125	0.080	0.100	0.080	0.200	0.100	0.400	0.200	0.200	0.100
 Lower Molar	kV	60	60	65	65	60	60	65	65	60	60	60	60	60	60	60	60
	mA	7	7	7	7	7	7	7	7	7	7	7	7	7	7	7	7
	sec	0.160	0.080	0.100	0.064	0.160	0.080	0.160	0.080	0.100	0.080	0.200	0.100	0.400	0.200	0.200	0.100
 Upper Molar	kV	60	60	65	65	60	60	65	65	60	60	60	60	60	60	60	60
	mA	7	7	7	7	7	7	7	7	7	7	7	7	7	7	7	7
	sec	0.200	0.100	0.125	0.080	0.200	0.100	0.200	0.125	0.125	0.080	0.250	0.100	0.500	0.200	0.250	0.100

12-inch Cone (30 cm)																	
Setting		Progeny®		Schick		Dexis®		Kodak		Sirona		PSP		D Speed		E/F Speed	
		Adult	Child	Adult	Child	Adult	Child	Adult	Child	Adult	Child	Adult	Child	Adult	Child	Adult	Child
 Incisor	kV	60	60	65	65	60	60	65	65	60	60	60	60	60	60	60	60
	mA	7	7	7	7	7	7	7	7	7	7	7	7	7	7	7	7
	sec	0.250	0.125	0.160	0.100	0.250	0.125	0.160	0.100	0.160	0.125	0.320	0.160	0.640	0.320	0.320	0.160
 Bicuspid	kV	60	60	65	65	60	60	65	65	60	60	60	60	60	60	60	60
	mA	7	7	7	7	7	7	7	7	7	7	7	7	7	7	7	7
	sec	0.250	0.125	0.160	0.100	0.250	0.125	0.250	0.160	0.160	0.125	0.320	0.160	0.640	0.320	0.320	0.160
 Bitewing	kV	60	60	65	65	60	60	65	65	60	60	60	60	60	60	60	60
	mA	7	7	7	7	7	7	7	7	7	7	7	7	7	7	7	7
	sec	0.320	0.160	0.200	0.125	0.320	0.160	0.250	0.160	0.200	0.160	0.400	0.200	0.800	0.400	0.400	0.200
 Lower Molar	kV	60	60	65	65	60	60	65	65	60	60	60	60	60	60	60	60
	mA	7	7	7	7	7	7	7	7	7	7	7	7	7	7	7	7
	sec	0.320	0.160	0.200	0.125	0.320	0.160	0.320	0.160	0.200	0.160	0.400	0.200	0.800	0.400	0.400	0.200
 Upper Molar	kV	60	60	65	65	60	60	65	65	60	60	60	60	60	60	60	60
	mA	7	7	7	7	7	7	7	7	7	7	7	7	7	7	7	7
	sec	0.400	0.200	0.250	0.160	0.400	0.200	0.400	0.250	0.250	0.160	0.500	0.200	1.000	0.400	0.500	0.200

## Arm and Tubehead

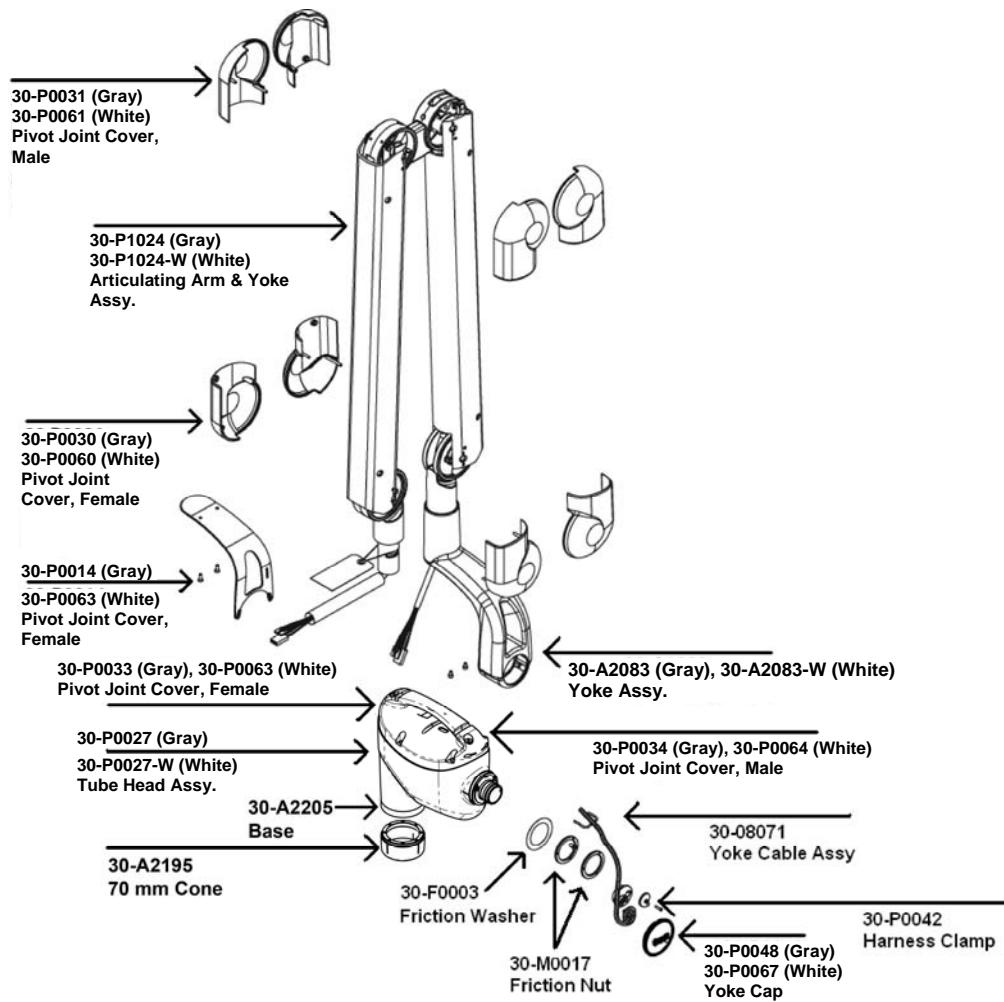


Figure 103  
Arm and  
Tubehead



## Horizontal Arm

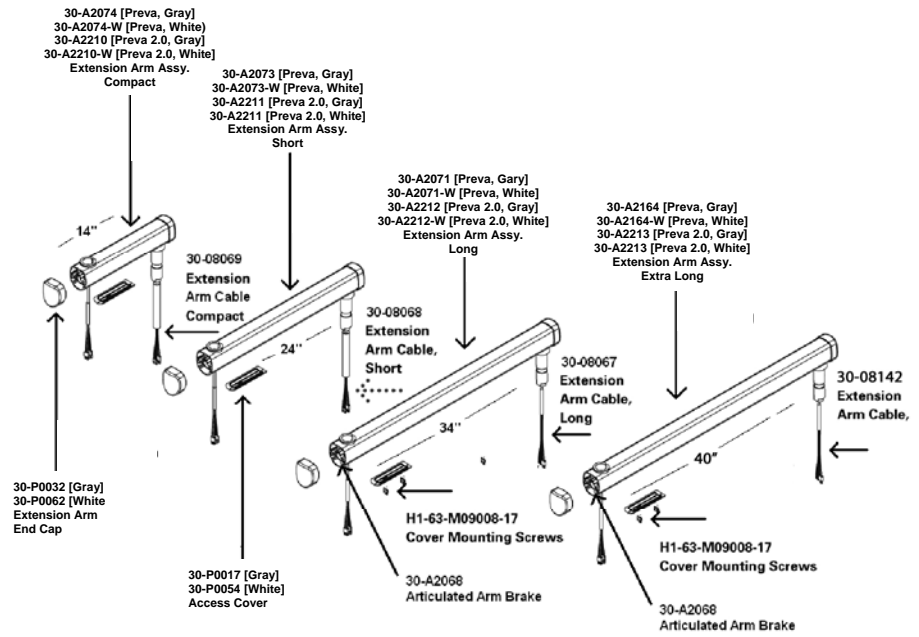


Figure 104  
Horizontal  
Arm



Art. Arm  
Brake  
30-A2068

## Mounting Plates

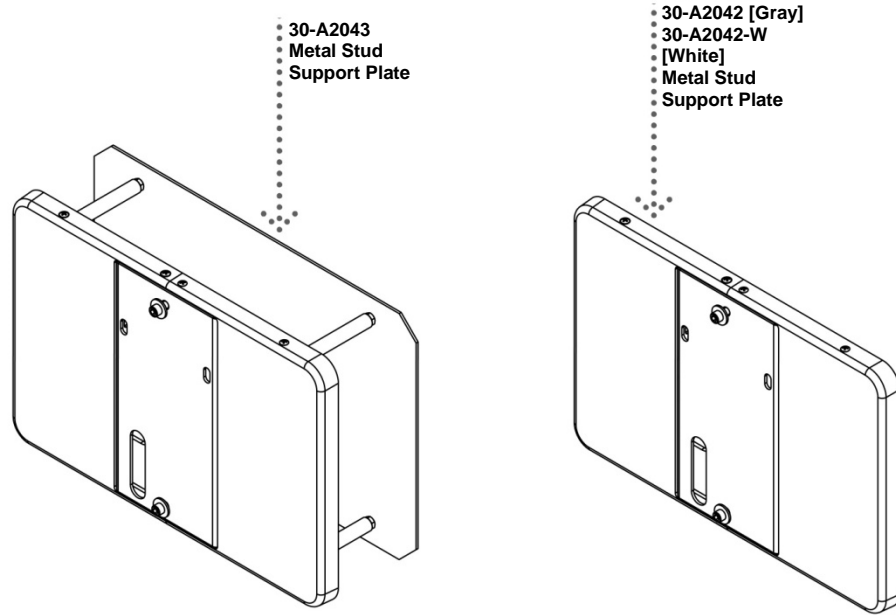


Figure 105  
Mounting  
Plates

## Operator Panel

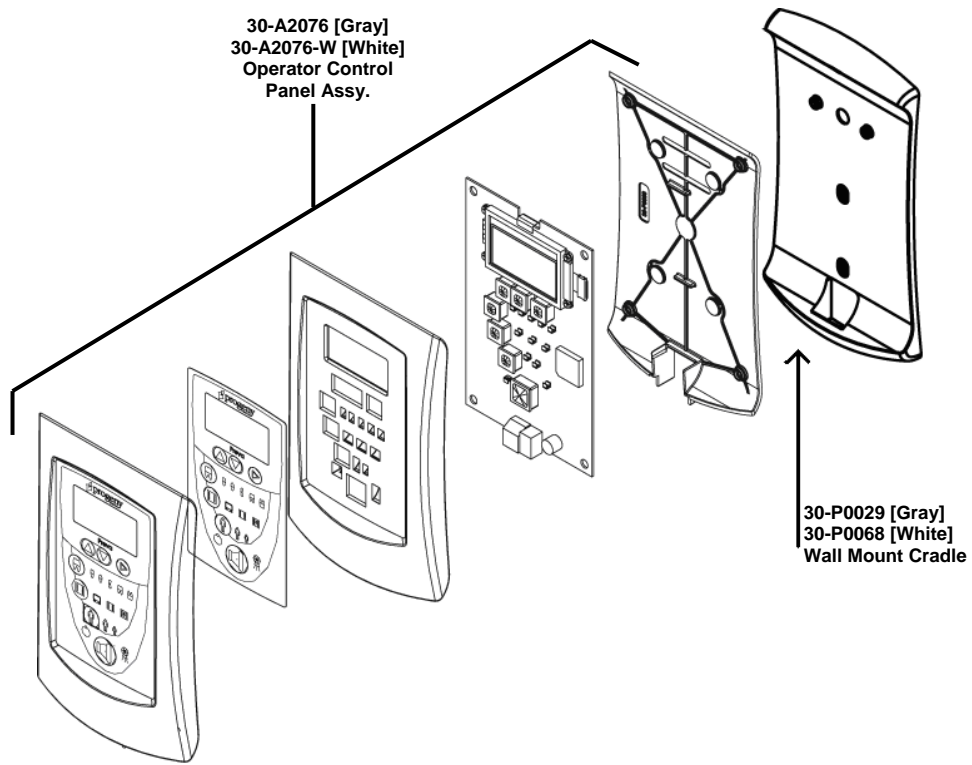


Figure  
106  
Operator  
Panel

**Cables**  
Cat 5  
50ft.  
E1-13034

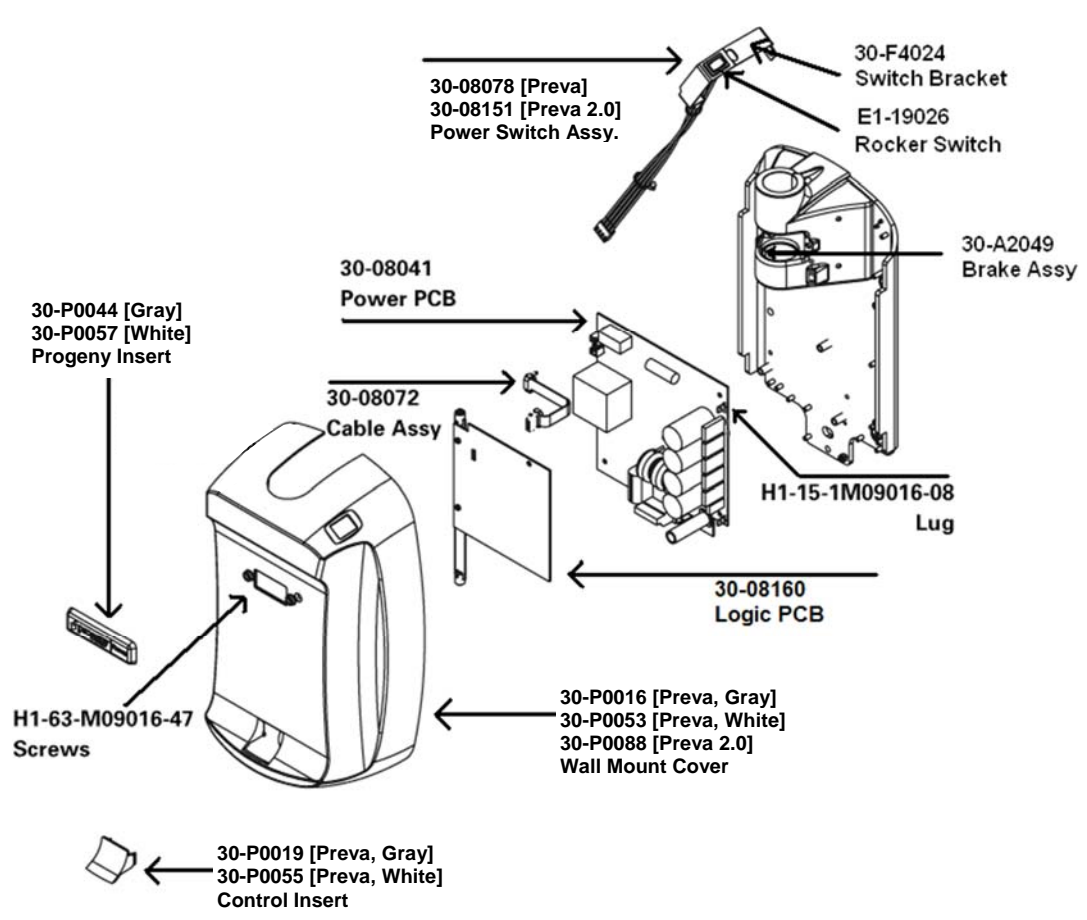
Cat 5  
25ft.  
E1-13003

Cat 5  
6 inch  
E1-13004

Exposure  
Cord  
Pigtail  
30-08035



## Control Unit



### For Preva 2.0

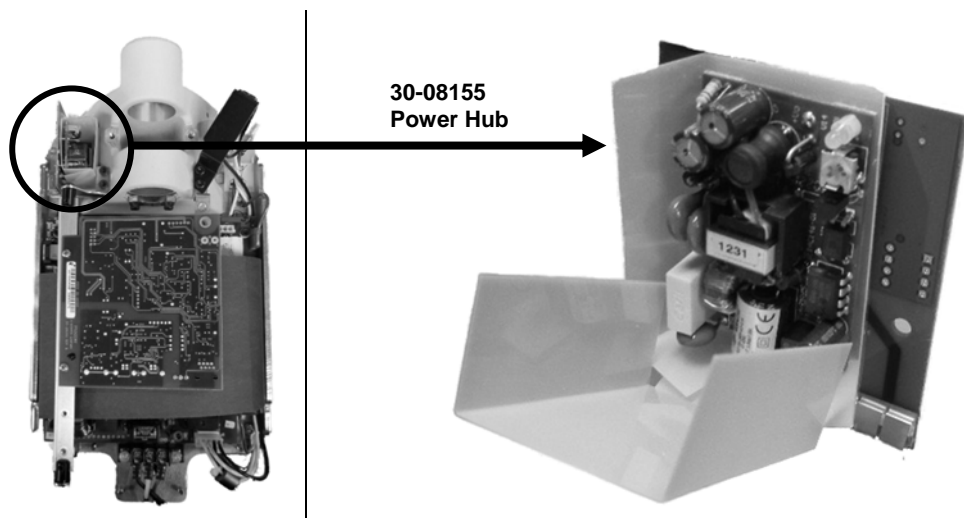


Figure  
107  
Control  
Unit  
Assembly

## Handswitch

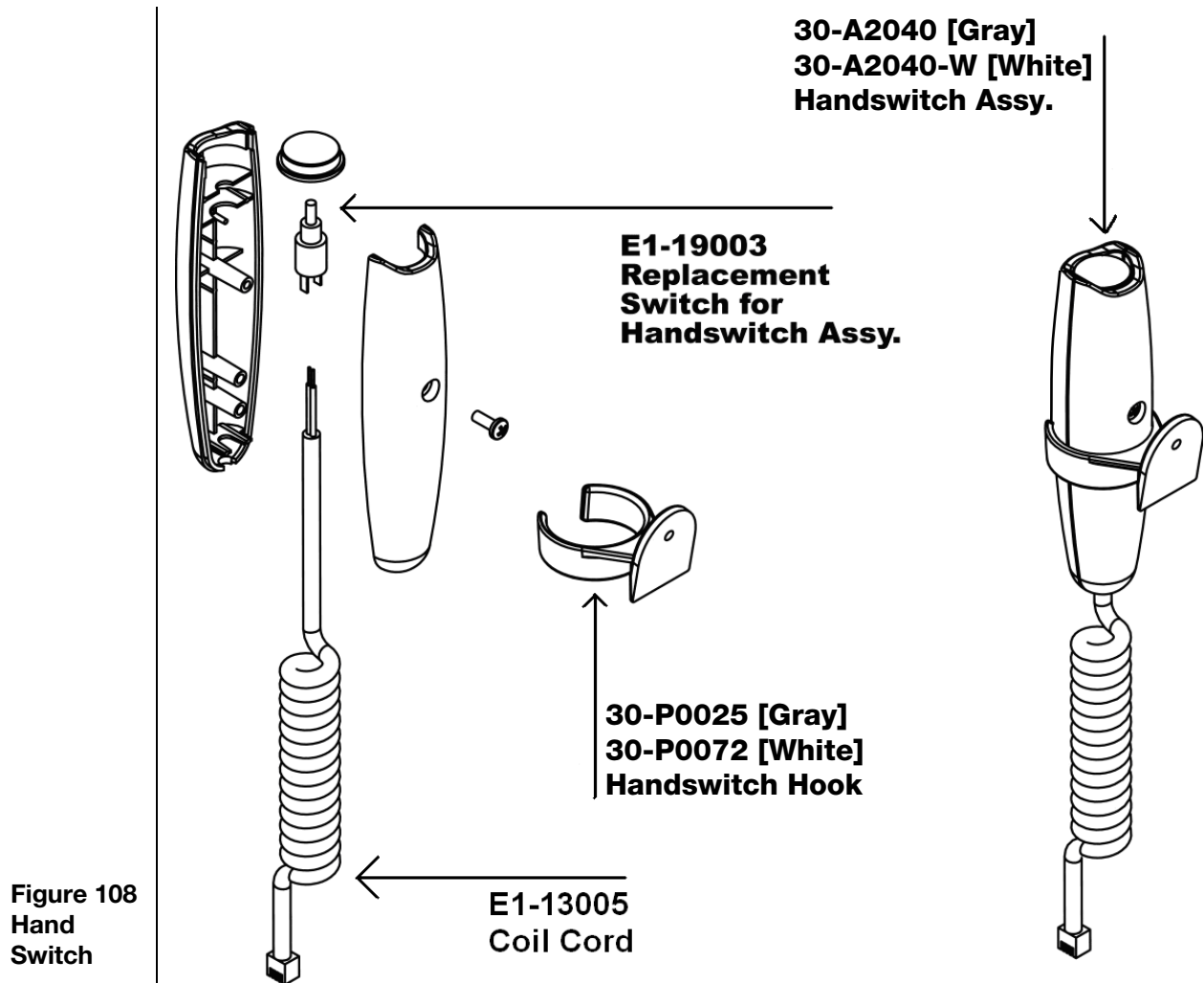


Figure 108  
Hand  
Switch

## Specifications

### Preva Dental X-ray System

<b>Line Voltage</b>	AC 100 V to 250 V, 50 Hz or 60 Hz
<b>Line Load</b>	250 V, UL Recognized – It is recommended that branch circuit does not exceed 15A
<b>Tube Potential</b>	60 kV, 65 kV, 70 kV
<b>Tube Current</b>	4 mA, 5 mA, 6 mA, 7 mA (7 mA is not available at 70 kV.)
<b>Irradiation Time</b>	20 ms through 2 s
<b>Minimum Source to Skin Distance</b>	8 inch (20 cm) 12 inch (30 cm)
<b>Focal Spot</b>	0.4 mm (per IEC 60336)
<b>Operating Temperature</b>	+50 °F to +95 °F (+10 °C to +35 °C)
<b>Storage Temperature</b>	-31 °F to +150 °F (-35 °C to +66 °C)
<b>Maximum Altitude</b>	12,000 ft (3,657 m)
<b>X-ray Beam Dimension</b>	Diameter of 2.72 inches (7 cm) at the end of the 7 inch Cone. Cones with smaller diameter or rectangular beams are available.
<b>Humidity Range (Operation &amp; Storage)</b>	10 to 80 % non-condensing

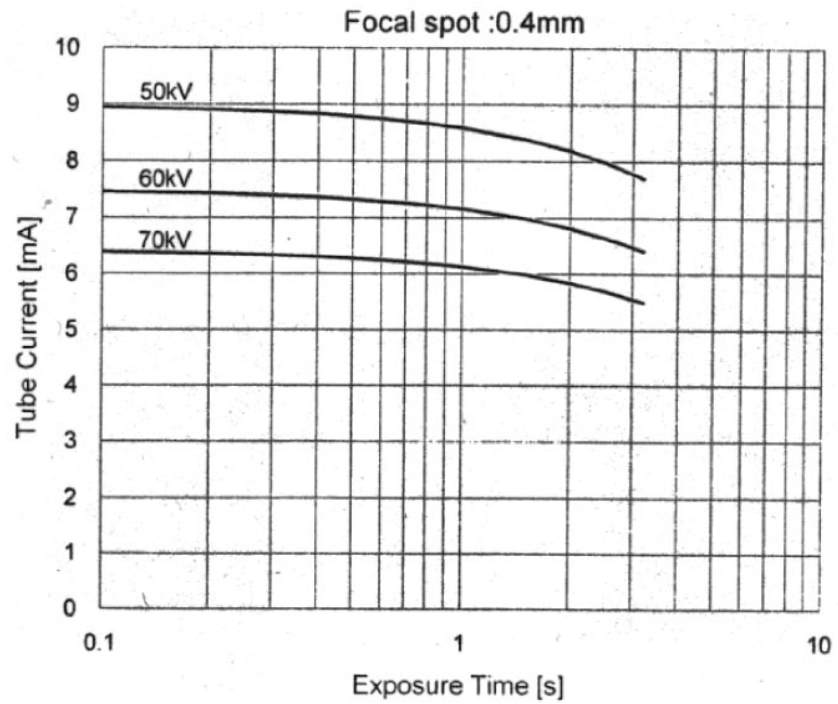
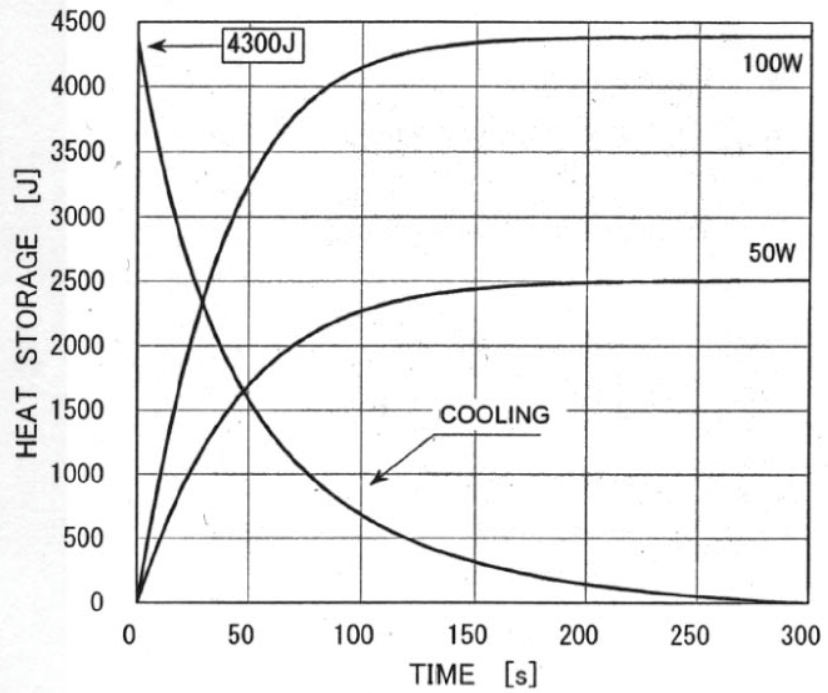


Figure 109  
Toshiba Tube Rating  
Charts

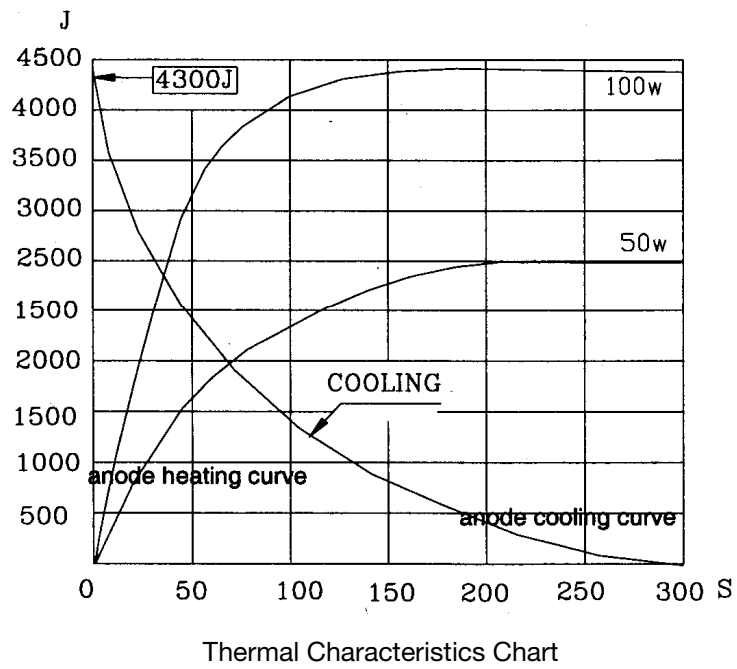
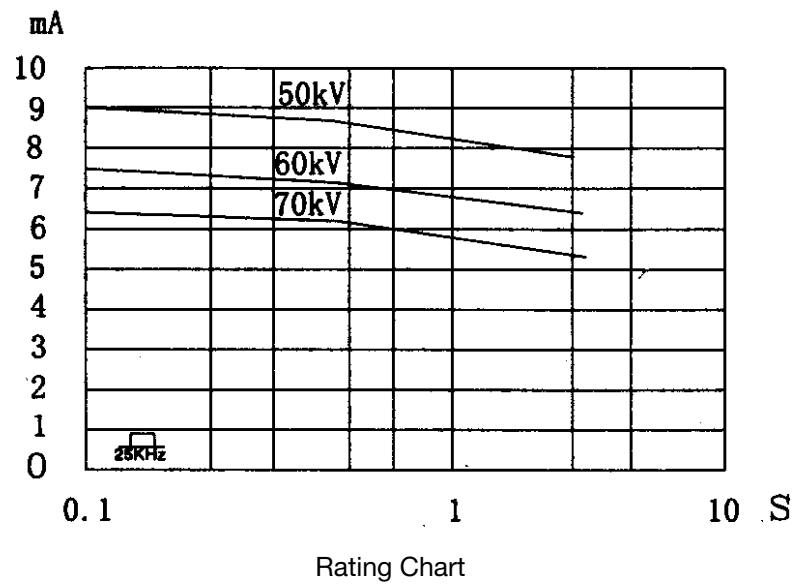


Figure 110  
Kailong Tube Rating  
Charts



## Appendix A

### Assembly Instructions for DC Mobile Unit

#### Tools Required

3/8" square drive hex key 10 mm  
3/8" square drive hex key x 6-inch extension  
3/8" square drive ratchet  
No. 1 Phillips screwdriver  
7 mm nut driver  
Small flat-blade screwdriver  
4 mm hex key  
5 mm hex key

1. Open the box from the top side.

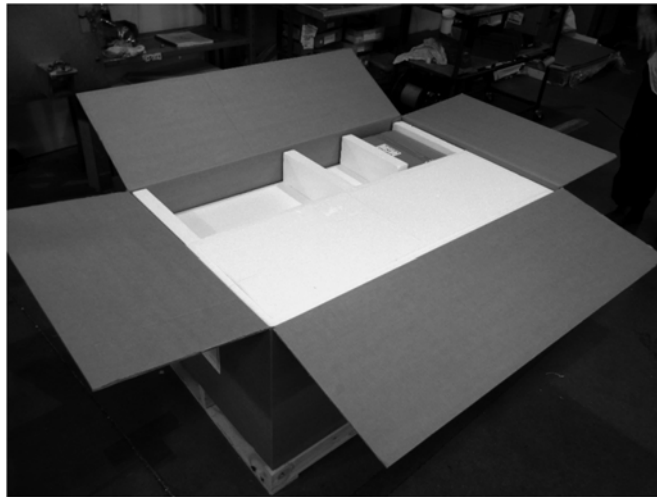


FIGURE 111

2. Remove all transportation screws from the base of the crate ( Qty. 10)



FIGURE 112

3. Lift the shipping box and separate from the crate. There are two layers of parts. Separate the top layer and place on the floor or remove each piece individually.

**NOTE: This is a two person job. Take extra care when handling the articulating arm assembly to avoid any damage to the tubehead.**



**FIGURE 113**

4. Cut the transportation band from the lower layer that holds the mobile base.



**FIGURE 114**

5. Remove top cover of control unit by removing screws located at the base of the cover.

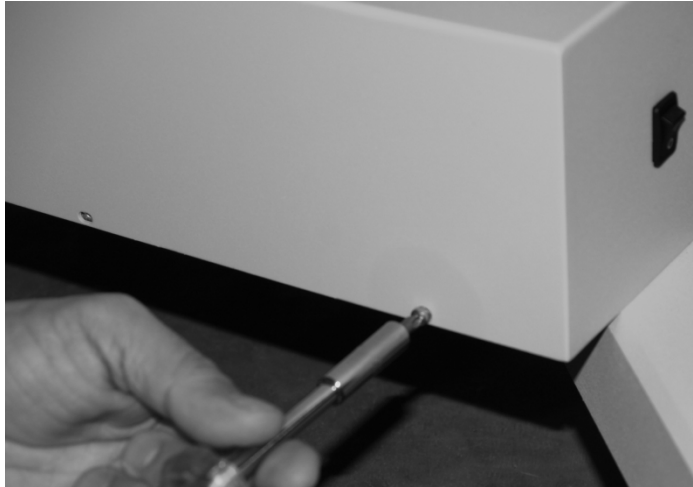


FIGURE 115

6. Separate the mobile unit base from the pallet.  
**CAUTION: This should be done taking proper lifting precautions. The base is heavy and requires two people to lift.**

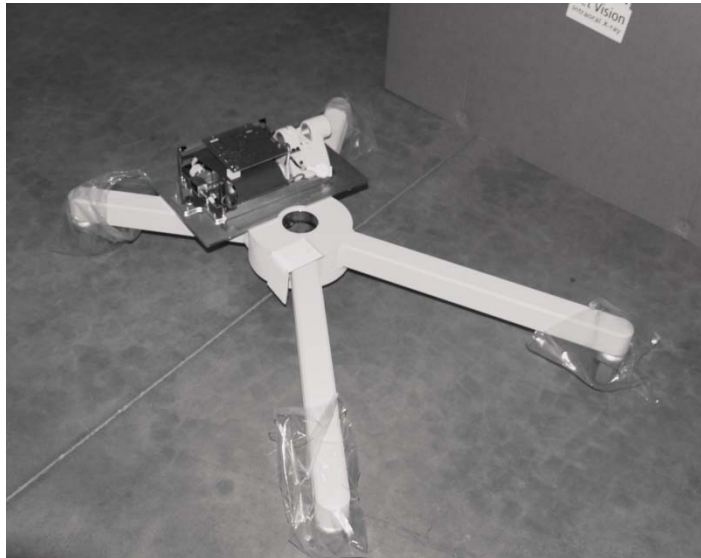


FIGURE 116

7. Locate the mobile unit post (located in the top layer of parts removed in step 3) and insert into the mobile base as shown.  
**NOTE: Take care not to pinch the Cat 5 cable or the tubehead connectors.**

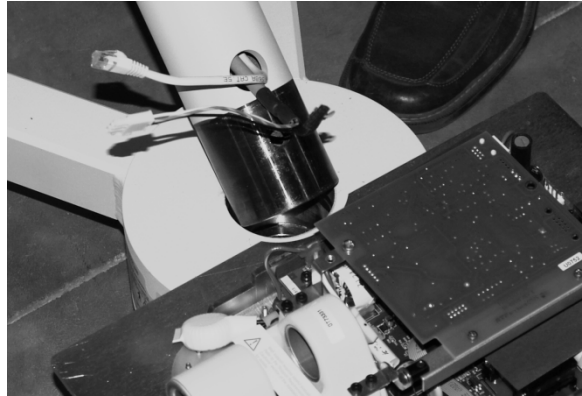


FIGURE 117

8. In the “Kit, Mobile Stand” package (Part #30-A2098). Locate and insert the bolt used to secure the post to the mobile base. (Requires 10mm Allen wrench.)

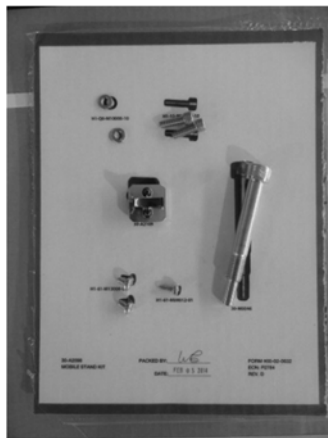
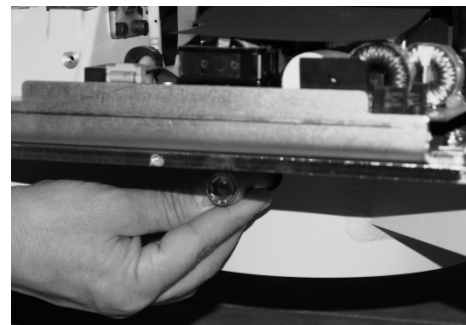


FIGURE 118  
FIGURE 119



9. Back out the Allen bolts used to secure the articulated arm to the post. (QTY 2). This allows the articulating arm to be inserted completely into post.



FIGURE 120

10. Locate the Articulated Arm/Tubehead assembly. Remove the red transportation label. Pull back the plastic packaging to expose shaft and remove paper tube protecting cables and connectors.
11. Lift the arm/tubehead carefully and guide the cables through the top of the post. Carefully insert the articulated arm and take care not to pinch or damage the connectors.



**FIGURE 121**

12. Secure the articulated arm assembly to the post with the two Allen bolts that were backed out in step 9.



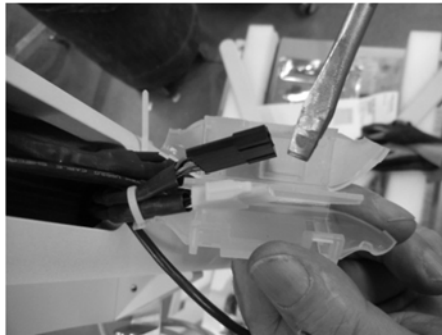
**FIGURE 122**

13. Locate and install the articulating arm brake assembly. Install and adjust by tightening to the point where the articulating arm does not drift when you lightly push the arm.



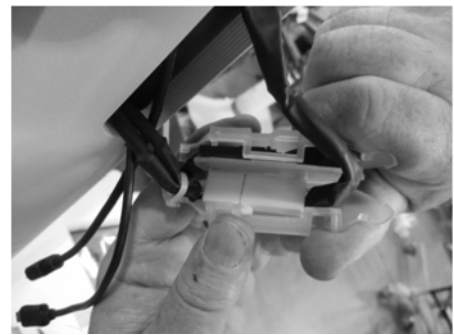
**FIGURE 123**  
**FIGURE 124**

14. Pry apart the Isolator containing the connectors for the cables. Connect the power cables (white connectors).



**FIGURE 125**  
**FIGURE 126**

15. Connect the feedback cables (black connectors). Insert cables into the Isolator, one on each side of the divider and snap shut.



**FIGURE 127**  
**FIGURE 128**

16. If the unit is a Preva 2.0 (Sensor ready), connect the USB cables. Insert cables into the post.

**FIGURE 129**  
**FIGURE 130**

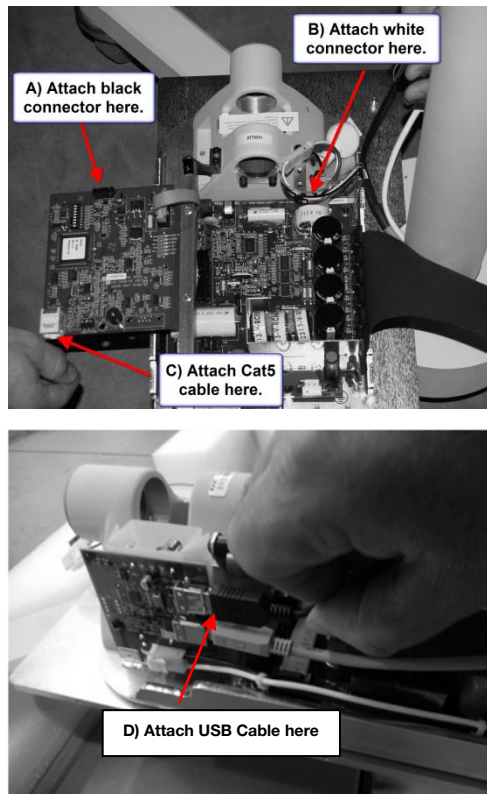


**17. Install the cover plate.**

**FIGURE 131**

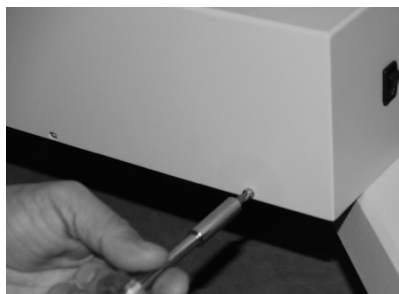


- 18.** Remove the screw that locks down the Logic board. Swing out the Logic Board and connect the three connections as shown below.
- A) Black connector (Feedback from tubehead)
  - B) White connector (Power to tubehead)
  - C) Cat5 (network cable)
  - D) USB (for Sensor ready units)



**FIGURE 132**

- 19.** Attach the control unit cover.

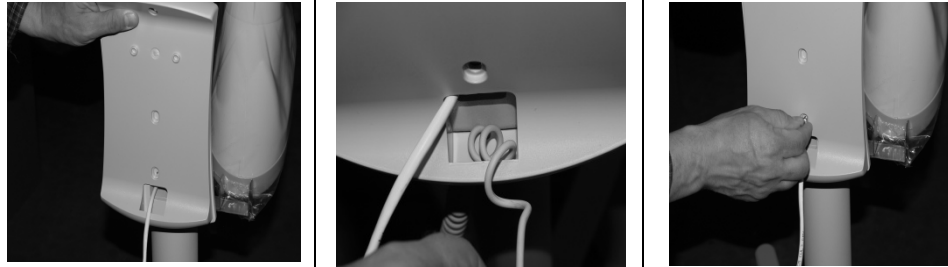


**FIGURE 133**



20. Feed the Cat5 cable through the Operator Panel Cradle. Feed remote exposure cable through the bottom of cradle. **NOTE: Allow a few coils of slack inside for strain relief.** Attach the cradle with supplied hardware.

FIGURE 134  
FIGURE 135  
FIGURE 136



21. Connect Cat5 cable and remote switch cable to the Operator Panel. Mount the Operator Panel into cradle.

FIGURE 137



22. Install the mobile unit handle with the supplied hardware.

FIGURE 138



- 23.** Attach the remote switch holster by removing the adhesive backer and attaching to the frame.



**FIGURE 139**

## Replacing the Power Cord

Tools Required

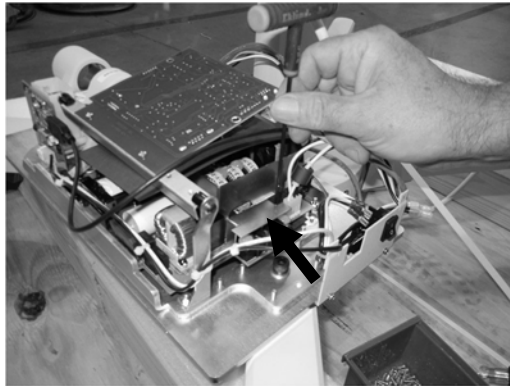
**FIGURE 140**

1. Remove the six (6) screws securing the cover.



**FIGURE 141**

2. Remove the EMI Shield Bracket.



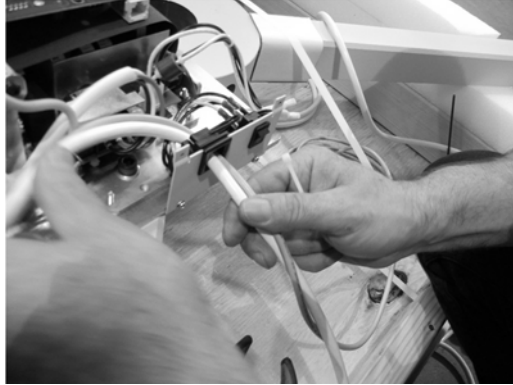
**FIGURE 142**

3. Remove the three (3) screws securing the power cord (Part# E1-13028).



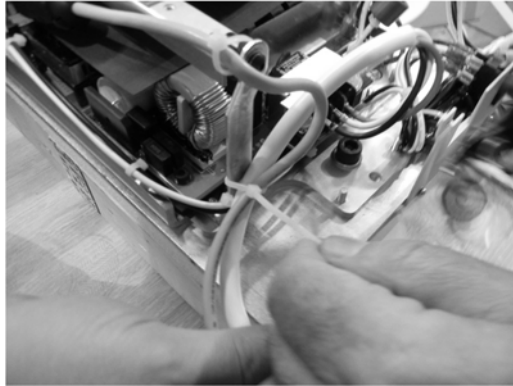
**FIGURE 143**

4. Slide the strain relief (Part# E1-22031) out of its slot.

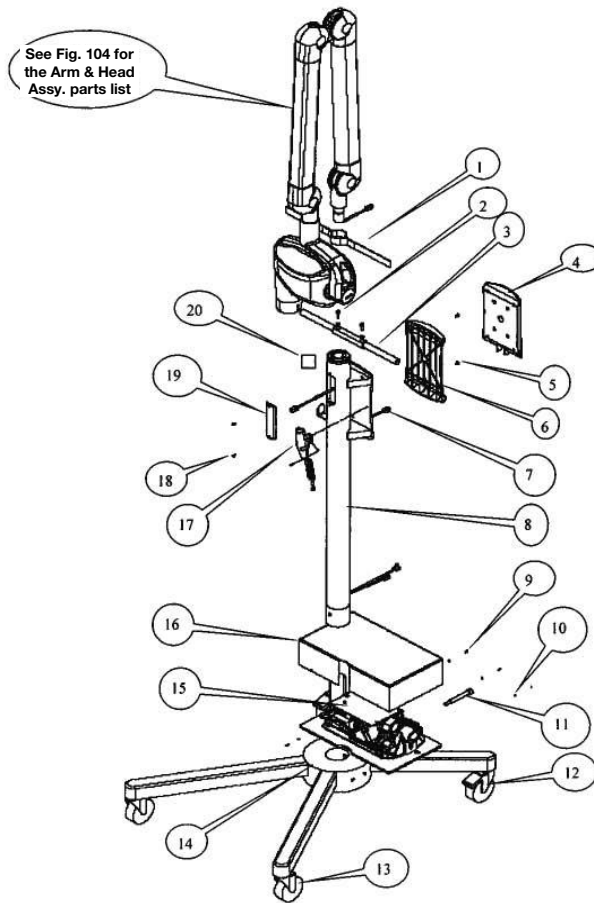


**FIGURE 144**

5. Cut the tie wrap to completely free the power cord for removal.



6. Reverse the procedure to install the new power cord.



**Figure 145**  
**Mobile Unit**  
**Assembly**

**Mobile Assembly Parts List**

Item	Part Number	Description	Qty
1	30-A2093	Velcro Strap	1
2	H1-15-M16020-10	Screw	2
3	30-A2111	Mobile Stand Handle w/Grips	1
4	30-A2076	Operator Panel (see Figure 106)	1
5	H1-61-M13008-01	Screw	2
6	30-M3010	Cradle	1
7	E1-13029	8 Cond. RJ45 to RJ45 2m	1
8	30-M0045	Column	1
9	H1-61-M05008-01	Screw	5
10	H1-P2-M04000-01	Washer	5
11	30-M0046	Column Screw	1
12	30-S0036	Caster, Swivel w/Brake	2
13	30-S0035	Caster, Swivel	2
14	30-A2078	Mobile Stand Base	1
15	30-A1032	Control (see Figure 107)	1
16	30-08098	Switch Assy., Preva Mobile Stand	1
17	30-A2040	Remote Control Switch Assy.	1
18	H1-63-M09008-17	Screw	2
19	30-P0017	Access Cover	1
20	30-A2109	Brake	1
21	E1-13028	Line Cord (Not Shown)	1

## Appendix B

### Electronics Block Diagram

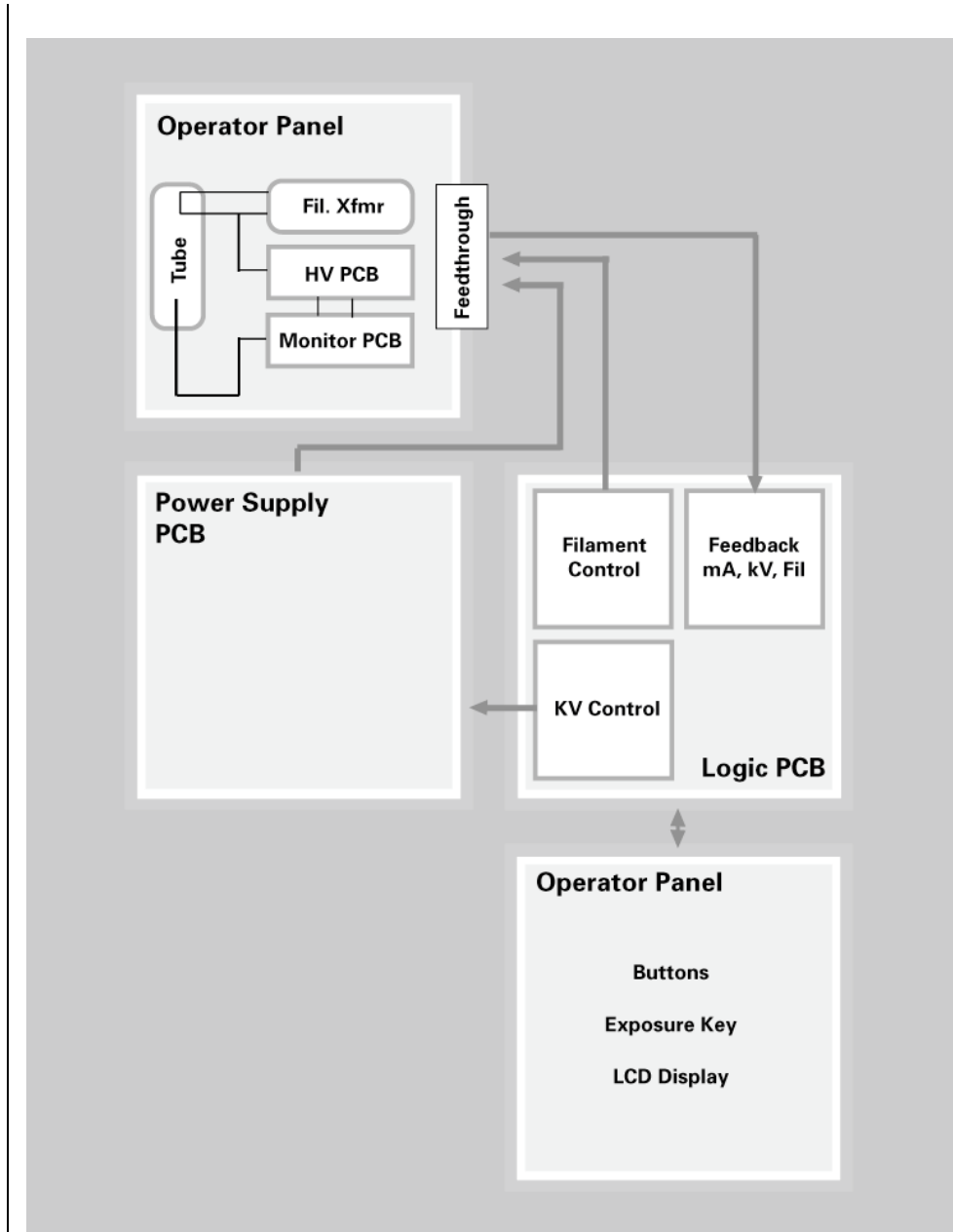


Figure 146  
Electronic Block  
Diagram