CARDELL[®] 9401 & 9402 Veterinary Monitor



Service Manual

Manufactured for:



CASMED
FOR WHAT'S VITAL

CE

CARDELL®
Veterinary Vital Signs Monitors

MODEL

DESCRIPTION

9401

Non-invasive Blood Pressure and Pulse Rate.

9402

Non-invasive Blood Pressure, Pulse Rate and Pulse Oximeter.

IMPORTANT:

This manual addresses all parameters of the CARDELL Veterinary Vital Signs Monitor. Not all monitors have all the parameters referred to in this manual.

Read this Manual completely before using this equipment.

WARNING:

The CARDELL Monitor is to be operated by qualified personnel only. Before use, carefully read this manual, including accessory directions for use, all precautionary information, and specifications. The user must check that the equipment functions safely and see that it is in proper working condition before being used.

HOW TO CONTACT US

<p>For Warranty Issues:</p> <p>CAS Medical Systems, Inc. 44 East Industrial Road Branford, CT 06405 U.S.A.</p> <p>Phone: (800) 227-4414 (203) 488-6056</p> <p>Fax: (203) 488-9438</p> <p>E-Mail: techsrv@camed.com</p> <p>Web: www.camed.com</p>	<p>For Product Usage Information:</p> <p>Midmark 10008 N. Dale Mabry Hwy, Suite 110 Tampa, FL 33618 U.S.A.</p> <p>Phone: Toll Free: 800-Midmark (643-6275)</p> <p>Fax: (813) 264-6218</p> <p>E-Mail: www.Midmark.com/Pages/Contactus.aspx</p> <p>Web: www.Midmark.com</p>
---	---

Copyright 2006 CAS Medical Systems, Inc.

All rights reserved. No part of this manual may be reproduced without the written permission of CAS Medical Systems, Inc. CAS reserves the right to make changes to this manual and improvements to the product it describes at any time without notice or obligation.

TABLE OF CONTENT

1. INTRODUCTION AND INTENDED USE..... 11
 INTRODUCTION..... 11
 BRIEF DEVICE DESCRIPTION 11
 PATIENT ENVIRONMENT 12
 MANUAL INFORMATION 13
 REVISION HISTORY..... 13
 MANUAL OVERVIEW 13
 INTENDED AUDIENCE..... 13
 DEFINITION OF TERMS..... 14
 RELATED DOCUMENTS 14
 MONITOR CONFIGURATIONS 14

2. SERVICE POLICY..... 15
 WARRANTY POLICY..... 15
 RETURNING THE MONITOR FOR REPAIR..... 16

3. SAFETY MEASURES AND WARNINGS..... 17
 AUTOMATIC SAFETY FEATURES..... 21

4. DECLARATION OF CONFORMITY..... 23

5. SYMBOLS 25

6. MONITOR CONTROLS..... 31
 FRONT PANEL 31
 DIGITAL DISPLAY AND INDICATORS 31
 FRONT PANEL CONTROLS..... 33
 INFRARED (IR) DATA PORT 36
 REAR PANEL 37
 AC LINE POWER CONNECTOR 37
 FUSE COMPARTMENT 37
 BATTERY COMPARTMENT 37
 EXTERNAL DEVICE INTERFACING 37
 LEFT SIDE VIEW 38
 CUFF HOSE CONNECTION 38
 NELLCOR VET SpO₂ SENSOR CONNECTION..... 38

7. MONITOR CONFIGURATION..... 39
 ENTERING THE MONITOR CONFIGURATION MENU 39
 SAVING YOUR CHANGES 39
 SOFTWARE REVISIONS..... 40
 SETTING THE LANGUAGE 40
 AUDIO ALARM SILENCE (SILENCE/RESET Pushbutton)..... 41
 2-MINUTE AUDIO ALARM SILENCE 41
 PERMANENT AUDIO ALARM SILENCE..... 41

CARDELL MONITOR SERVICE MANUAL

ALARM LIMITS OFF.....	42
MAP VALUE ENABLE / DISABLE	42
SET THE SpO ₂ ALARM DELAY	43
SETTING THE DATE	43
SETTING THE TIME	43
DAYLIGHT SAVING TIME OPTION	44
8. EXTERNAL DEVICE INTERFACING.....	45
OVERVIEW	45
RS232	45
9. ROUTINE MAINTENANCE	47
CLEANING.....	47
CLEANING OVERVIEW	47
THE MONITOR	47
THE DISPLAY	48
CUFFS	48
PNEUMATIC TUBING	49
PRINTER.....	49
SpO ₂ INTERCONNECT CABLE	49
SpO ₂ SENSORS.....	49
PNEUMATIC PRESSURE CHECK	50
SAFETY CHECKS	50
SYSTEM CHECKS.....	50
BATTERY.....	50
10. TROUBLESHOOTING	51
SYSTEM TROUBLESHOOTING.....	51
THEORY OF OPERATION	55
POWER SUPPLIES.....	55
BATTERY CHARGER.....	56
SUPERVISOR MICROCONTROLLER.....	56
DIGITAL SIGNAL PROCESSOR CONTROLLER.....	57
ERROR MESSAGES	59
SpO ₂ USER MESSAGES	59
ERROR MESSAGES ON THE MESSAGE WINDOW	60
11. MAINTENANCE PROCEDURES	63
INTRODUCTION.....	63
EQUIPMENT REQUIRED.....	63
BATTERY CHARGE.....	64
TURNING THE CARDELL MONITOR "ON"	64
DISPLAYING THE TIME	65
ALARM AUDIO.....	65
SpO ₂ AUDIO.....	66
CONFIGURATION MODE TESTS	66
ENTERING THE TEST MODE	66
EXIT THE TEST MODE.....	67
LED CHECK.....	67

+12 VOLT POWER SUPPLY CHECK	67
CALIBRATION CHECK	67
SYSTEM PRESSURE	68
OVERPRESSURE	68
PNEUMATIC PRESSURE CHECKS	69
PLUG TUBE	69
500 ml PRESSURE CHECK	69
NIBP SIMULATOR CHECK	70
OXIMETRY CALIBRATION CHECK	70
SpO ₂ SIMULATOR CHECK	70
ELECTRICAL SAFETY CHECKS	70
LEAKAGE	70
HYPOT (Monitor)	71
HYPOT (SpO ₂)	71
DATA SHEET	73
12. SERVICE PROCEDURES	75
INTRODUCTION	75
TOOLS REQUIRED	75
REPLACING THE MONITOR BATTERY	76
REMOVING THE BATTERY	76
INSTALLING THE BATTERY	76
CHANGING THE FUSES	77
CARDELL	77
MAIN MONITOR SERVICE PROCEDURES	78
PRIOR TO DISASSEMBLY	78
MONITOR DISASSEMBLY	78
MONITOR ASSEMBLY	78
REPLACING THE POWER SUPPLY MODULE	79
REPLACING THE NIBP MODULE	80
REPLACING THE SpO ₂ MODULE	81
REPLACING THE MAIN CONTROL BOARD	82
REPLACING THE FRONT PANEL KEYSWITCH	83
MODULE SERVICE PROCEDURES	84
REPLACING THE RS232 INTERFACE BOARD	84
13. SCHEMATICS	87
NIBP BOARD	87
MAIN CONTROL BOARD	88
NONIN INTERFACE BOARD	100
RS 232 INTERFACE BOARD	101
PROPRIETARY BOARDS	103
14. SPARE PARTS	105
PRINTED CIRCUIT BOARDS	105
SWITCHES/CONTROLS/CONNECTORS	105
CABLES	105
MISC PARTS	106
15. SPECIFICATIONS	107

FIGURES

Figure 1: Patient Environment.....	12
Figure 2: Front Panel View.....	31
Figure 3: Front Controls	33
Figure 4: Rear Panel View	37
Figure 5: Left Panel Views	38
Figure 6: DB9 Male Connector Pin Layout.....	46
Figure 7: Overall Block Diagram	51
Figure 8: No Monitor Power	52
Figure 9: Power-Up Response.....	53
Figure 10: SpO ₂ Trouble Shooting	54
Figure 11: Removing the Battery	76
Figure 12: Replacing the Power Supply Module.....	79
Figure 13: Replacing the NIBP Module	80
Figure 14: Replacing the SpO ₂ Module	81
Figure 15: Replacing the Main Control Board	82
Figure 16: Replacing the Front Panel Membrane Keyswitch.....	83
Figure 17: Replacing the RS232 Interface Board	84

TABLES

Table 1: Parts of the System.....	12
Table 2: Monitor Configurations	14
Table 3: Software Revisions	40
Table 4: DB9 Pin Out.....	46
Table 5: Error Messages on the Message Window	60

This page is intentionally left blank

1. INTRODUCTION AND INTENDED USE

INTRODUCTION

The CARDELL Veterinary Monitors, Models 9401 and 9402, are vital signs monitors measuring blood pressure and oxygen saturation. The monitors are restricted for use, one patient at a time. Non-invasive blood pressure is measured using the oscillometric technique determining systolic, diastolic, mean arterial pressure and pulse rate. The pulse oximeter function continuously monitors and displays values for functional arterial hemoglobin saturation and a pulse rate.

BRIEF DEVICE DESCRIPTION

The CARDELL Monitor is compact, lightweight and portable, allowing it to be easily carried and used in a variety of clinical settings. The monitor is powered by AC Line Power or by a Nickel Metal Hydride (NiMH) rechargeable battery pack. The internal battery pack charges when the monitor is plugged into the AC wall outlet. The CARDELL Monitor can be set to operate in one (1) of nine (9) different languages: English, German, French, Italian, Spanish, Dutch, Swedish, Portuguese or Norwegian. The message window can display various system alarm messages. These messages direct the user to check conditions such as the battery state, air leaks and measurement problems. The message window also displays the operational mode of the monitor (automatic or manual).

The non-invasive blood pressure (NIBP) parameter automatically inflates an occluding cuff and, using the oscillometric measurement technique, determines systolic, diastolic and mean arterial pressure and pulse rate. Measurement results along with operator prompts and error messages are displayed on the front panel. The frequency of NIBP determination can be selected by the operator in varied times between one and ninety minutes. The auto and manual operating modes cover a variety of clinical uses.

The pulse oximeter parameter (%SpO₂) determines arterial oxyhemoglobin saturation by measuring the absorption of red and infrared light passing through the tissue. Changes in absorption caused by pulsations of blood in the vascular bed are used to determine arterial saturation and pulse rate. The oximeter requires no routine calibration or maintenance. Oxygen saturation and heart rate are displayed on light emitting diode (LED) digital displays.

On each detected pulse, the perfusion LED does indicate patient perfusion signals. This bar graph gives the user a pulse-by-pulse visual indication of waveform signal quality. An audio "beep" can be enabled that is generated each time the SpO₂ module detects a pulse.

NOTE:

The bar graph is not proportional to the pulse volume.

PATIENT ENVIRONMENT

The CARDELL Monitor has been tested with specific parts of the “system” used within the Patient Environment. **Figure 1**, defines the Patient Environment.

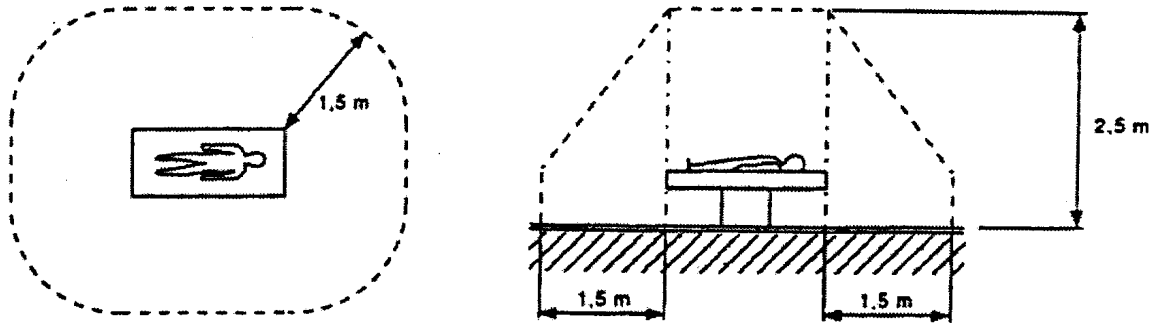

Figure 1: **Patient Environment**

The parts of the CARDELL Monitor “system” that can be used in the Patient Environment are defined as;

The CARDELL Monitor (9401 / 9402)
Appropriate Accessories, listed in the ACCESSORIES section of the User’s Manual
Line Cord
Optional RS232 Interface
Citizen CMP-10 Mobile Printer
RS232 Interconnect Cable (supplied with printer)
AC Adapter / Charger, Model TRC-09-1100-M from Group West or equivalent (supplied with printer)

Table 1: **Parts of the System**

MANUAL INFORMATION

REVISION HISTORY

Each page of this manual has the document part number and revision letter at the bottom of the page. The revision letter identifies the document's update level. The revision history of this document is summarized below.

Revision History		
Revision	Date	Comments
00	08/2006	Initial Release
01	05/2008	Updated for 1.25A fuse

MANUAL OVERVIEW

This manual contains information for diagnosing and servicing the CARDELL Monitor to board level without the necessity of electrical schematics. Only qualified service personnel should service this product.

It is the user's responsibility to ensure that the product is properly maintained and that the monitor is in safe and proper operating condition before being put into use.

Before servicing the CARDELL Monitor, read the User's Manual carefully.

CAS Medical Systems, Inc. believes the information herein is complete and accurate, but accepts no liability for errors, omissions, or misrepresentations.

INTENDED AUDIENCE

This manual is intended for service representatives and technical personnel who maintain, troubleshoot, or repair this equipment.

DEFINITION OF TERMS

In this manual, “WARNING”, “CAUTION”, “IMPORTANT” and “NOTE” mean the following:

<p style="text-align: center;">WARNING:</p> <p>Directions that warn of conditions that put the patient or caregiver at risk.</p>

<p style="text-align: center;">CAUTION:</p> <p>Directions that help you avoid damaging your monitor or losing data.</p>
--

<p style="text-align: center;">IMPORTANT:</p> <p>Directions you should be particularly aware of; something not readily apparent.</p>

<p style="text-align: center;">NOTE:</p> <p>Directions that make it easier to use your monitor.</p>
--

RELATED DOCUMENTS

To perform test and troubleshooting procedures, you must know how to operate the monitor. Refer to the CARDELL User’s Manual.

MONITOR CONFIGURATIONS

Model	Description
9401	MAXNIBP® Non-invasive Blood Pressure and Pulse Rate, 100-240V, 50/60HZ, AC Power Supply and Battery
9402	MAXNIBP® Non-invasive Blood Pressure, Pulse Rate and Veterinary SpO ₂ , 100-240V, 50/60HZ, AC Power Supply and Battery

Table 2: **Monitor Configurations**

2. SERVICE POLICY

WARRANTY POLICY

MONITORS

CAS Medical Systems, Inc. warrants the monitor, when new, to be free from defects in material and workmanship and to perform in accordance with manufacturer's specifications for a period of three (3) years from the date of original purchase from CAS or its authorized distributors or agents except as noted below.

The same warranty conditions are made for a period of one (1) year with respect to printer and battery, (180 days on Nellcor/90 days on Nonin) non-disposable accessories and certain components consisting of reusable SpO₂ sensors and other accessories provided by CAS as part of the original purchase. CAS warrants blood pressure cuffs and disposable or single-patient-use products for out-of-box failure only. Where the accessory is not a CAS manufactured product, the manufacturer's own warranty conditions apply.

CAS reserves the right to perform warranty service operations in its own factory or at an authorized repair station.

Our obligation under this warranty is limited to repairing or, at our option, replacing any defective parts or our equipment, without charge, if such defects occur in normal service and with prompt notification.

Damage to any part through misuse, neglect, or accident, or by affixing any accessories or attachments other than CAS, Nellcor® or Nonin® manufactured accessories or attachments, is not covered by this warranty.

ACCESSORIES, BATTERIES, CUFFS, AND CERTAIN COMPONENTS

In all cases, policy applies from date of purchase from CAS or its authorized distributors or agents.

Accessories:	(90) Days - Nonin SpO ₂ Sensor. (180) Days - Nellcor SpO ₂ Cable and Sensor.
Batteries:	(1) Year
Chargers:	(1) Year (not including power cord: see other accessories).
Cuffs (all):	Out-of-box failure only.
Other Accessories:	Out-of-box failure only.
Certain Components:	(1) Year - Printer mechanism, but not including Thermal Print Heads.
Print Heads:	Out-of-box failure only.

THERE ARE NO WARRANTIES, WHICH EXTEND BEYOND THOSE EXPRESSLY DESCRIBED IN THIS AGREEMENT AND THE COMPANY MAKES NO WARRANTIES OF MERCHANTABILITY OR FITNESS FOR A PARTICULAR PURPOSE.

RETURNING THE MONITOR FOR REPAIR

Before returning a product for repair you must obtain authorization from CAS Medical Systems. An RMA (Return Materials Authorization) number will be given to you by our Service Department. Be sure to note this number on the outside of your shipping box. Returns without an RMA number will not be accepted for delivery.

NOTE:

Save the original shipping container and it's inside packing material should the monitor need to be returned for service.

Refer to the section *How To Contact Us*, found in the front of this manual, for important telephone numbers, fax numbers and email addresses.

3. SAFETY MEASURES AND WARNINGS

WARNING:

The CARDELL MODEL 9401 and 9402 monitors are intended for VETERINARY USE ONLY. Do not use on human patient.

Do not use this instrument for any purpose other than specified in this manual. Doing so will invalidate the monitor's warranty.

Do not connect more than one (1) patient to the monitor.

Do not plug the monitor into an outlet controlled by a wall switch.

The position of subject, physiological condition, and other factors affect the readings.

Blood pressure and pulse can fluctuate greatly between measurements; the monitor cannot alert the user to changes in vital signs occurring between measurement cycles.

Occasionally, electrical signals at the heart do not produce a peripheral pulse. If a patient's beat-to-beat pulse amplitude varies significantly (for example, pulsus alternans, atrial fibrillation, rapid-cycling artificial ventilator), blood pressure and pulse rate readings can be erratic and an alternate measuring method should be used for confirmation.

Where the integrity of the external protective conductor in the installation or its arrangement is in doubt, EQUIPMENT shall be operated from its INTERNAL ELECTRICAL POWER SOURCE.

Isolation of product from mains can only be achieved by removal of external power cord.

Do not, under any circumstances, perform any testing or maintenance on the monitor or power cord while the unit is being used to monitor a patient. Unplug the power cord before cleaning or servicing the monitor. The operator should not perform any servicing except as specifically stated in this manual.

Do not touch part of non-medical electrical equipment in the patient environment after removal of covers, connectors etc... without the use of a tool which operate at voltages not exceeding 25 VAC or 60 VDC and the patient at the same time.

Do not use a frayed or damaged power cord, or any accessory if you notice any sign of damage. Contact Midmark for assistance.

Equipment not suitable for use in the presence of a FLAMMABLE ANESTHETICS.

Equipment is not intended to be used in Oxygen Enriched Atmospheres.

Do not gas sterilize or autoclave the monitor.

Do not use the monitor in the presence of Magnetic Resonance Imaging (MRI) equipment.

WARNING:

Do not apply the blood pressure cuff on an extremity being used for an intravenous infusion.

Do not place liquids on top of the monitor. Do not immerse the monitor or power cord in water or any liquid. If unit is accidentally wetted it should be thoroughly dried. The rear cover can be removed by a qualified service technician to verify absence of water.

Accurate oxygen saturation measurement cannot be obtained with the Model 9402 when the oximeter is not measuring the pulse properly. If the perfusion bar graph or the PULSE RATE be erratic or inaccurate, first examine the animal for any signs of distress and only then re-examine sensor placement.

Inadequate perfusion, thick fur, dark skin or foreign matter that blocks light or an improperly applied sensor can result in erratic and inaccurate oxygen saturation and/or pulse rate measurement. Should the perfusion bar graph be at a low level, reposition the sensor or try a different sensor. If proper operation cannot be verified, remove the sensor from the animal and do not use the oximeter on this animal.

In the event the sensor becomes dislodged from the animal, audible and visual alarms are activated requiring that a veterinary professional investigate the reason for the alarm status. The veterinary professional should investigate status and sensor attachment after every sensor alarm indication. It is possible when the sensor is dislodged from the animal (under certain conditions of light and vibration of the sensor) for the pulse oximeter to display normal physiological values.

ACCURACY – If the accuracy of any measurement does not seem reasonable, first check the patient's vital signs by alternate means and then check the CARDELL Monitor for proper functioning.

CABLES – Route all cables away from patient's throat to avoid possible strangulation.

DEFIBRILLATION – Do not come in contact with patients during defibrillation. Serious injury or death could result.

DISPOSAL – Dispose of the packaging material, observing the applicable waste control regulations.

LEAKAGE CURRENT TEST – The interconnection of auxiliary equipment with this device may increase the total leakage current. When interfacing with other equipment, a test for leakage current must be performed by a qualified biomedical engineering personnel before using with patients. Serious injury or death could result if the leakage current exceeds applicable standards. The use of accessory equipment not complying with the equivalent safety requirements of this equipment may lead to a reduced level of safety of the resulting system. Consideration relating to the choice shall include: use of the accessory in the patient vicinity; and evidence that the safety certification of the accessory has been performed in accordance with the appropriate IEC 601.1 and/or IEC 601.1.1 harmonized national standard.

SITE REQUIREMENTS – For safety reasons, all connectors for patient cables and sensor leads are designed to prevent inadvertent disconnection, should someone pull on them. Do not route cables in a way that they may present a stumbling hazard. For devices installed above the patient, adequate precautions must be taken to prevent them from dropping on the patient.

CAUTION:

Before each use, make sure that the monitor default alarm settings are appropriate for the specific patient being monitored.

Pressing the front panel keyswitch with a sharp or pointed instrument may permanently damage the keyswitch. Press the keyswitch using only your finger.

As with any non-invasive oscillometric blood pressure monitor, the accuracy of the measurements obtained may be adversely affected by the presence of agents which alter the patient's cardiovascular system.

A calibration check is recommended once every year.

Do not alter the monitor's air hose. CAS Medical Systems cannot ensure proper monitor performance if the tubing is altered. Modification of the air hose will void the warranty. Avoid compression or restriction of pressure tubes.

If the cuff is applied on a limb being used for oxygen saturation monitoring %SpO₂ results will be altered during each blood pressure measurement due to the occlusion of blood flow.

Inspect the monitor, air hose and sensors for any damage prior to operation. If any damage is noted, the monitor should not be used until it has been serviced. The monitor should be repaired only by personnel authorized to do so by CAS Medical Systems, Inc.

Use only CAS Medical Systems approved accessories and sensors to preserve the integrity, accuracy and the electromagnetic compatibility of the monitor.

Consult a veterinarian for interpretation of blood pressure measurements.

The oximeter is factory calibrated to determine the percentage of arterial oxygen saturation of functional hemoglobin.

Significant levels of dysfunctional hemoglobins such as carboxyhemoglobin or methemoglobin may affect the accuracy of the measurement.

Cardiogreen and other intravascular dyes, depending on the concentration, may affect the accuracy of the oximeter measurement.

Some sensors may not be appropriate for a particular patient. If at least ten seconds of one bar pulses cannot be observed for a given sensor, change sensor location until this condition is achieved.

If the monitor fails to respond, do not use it until the situation has been corrected by qualified personnel.

CAUTION:

ACCIDENTAL SPILLS – In the event that fluids are accidentally spilled on the monitor, take the monitor out of operation and inspect for damage.

BATTERY POWER – If the monitor will not be used or not connected to AC line power for a period over six (6) months, remove the battery.

ELECTRICAL SHOCK – To reduce the risk of electrical shock, do not remove the back cover. Refer all servicing to qualified personnel.

ELECTROMAGNETIC COMPATIBILITY (EMC) – The equipment needs special precautions regarding EMC. Be aware that strong electromagnetic fields may interfere with monitor operation. Interference prevents the clear reception of signals by the monitor. If the hospital is close to a strong transmitter such as TV, AM, or FM radio, police or fire stations, a HAM radio operator, an airport, or cellular phone, their signals could be picked up as signals by the monitor. If you feel interference is affecting the monitor, contact your CAS Medical Systems representative to check the monitor in your environment.

ELECTROSURGERY – Measurements may be affected in the presence of strong electromagnetic sources such as electro surgery equipment.

GROUNDING – Do not defeat the three-wire grounding feature of the power cord by means of adaptors, plug modifications, or other methods. Do not use extension cords of any type. Do not connect the monitor to an electrical outlet controlled by a wall switch or dimmer.

INTERFACING OTHER EQUIPMENT – Monitoring equipment must be interfaced with other types of medical equipment by qualified biomedical engineering personnel. Be certain to consult manufacturers' specifications to maintain safe operation.

STACKING – Where monitor is used adjacent to or stacked with other equipment, the monitor should be observed to verify normal operation in the configuration in which it will be used.

GENERAL NOTES:

There are no known risks with common disposal of equipment or accessories; however, the disposing of accessories should follow in accordance with local hospital policies. The user should ensure these policies do not conflict with any local, state or federal guidelines.

The monitor is suitable for use in the presence of electro surgery.

The monitor is suitable to be connected to public AC mains power.

The CARDELL Monitor is not "Category AP or APG Equipment".

The CARDELL Monitor is for "Continuous Operation".

The CARDELL Monitor applied parts are "Type BF Defibrillation Proof".

The CARDELL Monitor provides "DRIP-PROOF" level of protection from ingress to moisture. Do not expose the CARDELL Monitor to extreme moisture levels such as direct exposure to rain. Exposure to extreme moisture levels may cause incorrect or inaccurate performance or device failure during or after exposure.

AUTOMATIC SAFETY FEATURES

The monitor has been designed for patient safety. The maximum amount of time allowed to complete a blood pressure measurement is 150 seconds. If the measurement has not been completed within that time, the cuff is deflated automatically and a message is displayed indicating the problem.

To prevent exposure of the extremity to an inordinately high pressure, the cuff is deflated automatically when the pressure in the system is greater than 290 mmHg.

In the event of a microprocessor failure, the cuff will be deflated automatically within ten (10) seconds.

All equipment parts are protected against the effects of the discharge of a defibrillator. No separate actions are required when using this equipment with a defibrillator.

Should the AC power be interrupted coming into the monitor, the monitor automatically runs off battery power. An indication of this would be a change in color of the Battery Charge LED from Green to either Orange or Red.

Whenever the power is disconnected from the monitor and the monitor is not allowed to shut down in an orderly fashion, the monitor, when re-powered alerts the user.

CAUTION:

Regardless of these safety features, always be sure to check that there are no signs of prolonged impairment of patient circulation and that the monitor is functioning properly.

CARDELL MONITOR SERVICE MANUAL

Whenever the power is disconnected from the monitor and the monitor is not allowed to shut down in an orderly fashion, the monitor, when re-powered alerts the user.

CAUTION:

Regardless of these safety features, always be sure to check that there are no signs of prolonged impairment of circulation and that the monitor is functioning properly.

4. DECLARATION OF CONFORMITY

Manufacturers Declaration of Conformity Electronic Emissions and Immunity

The Model 9401/9402 Monitor is intended for use in the electromagnetic environment specified below. The customer or the user of the Model 9401/9402 Monitor should assure it is used in such an environment.

Emissions Test	Compliance	Electromagnetic Environment
RF emissions – CISPR 11	Group 1	The Model 9401/9402 Monitor uses RF energy only for its internal function. Therefore, its RF emissions are very low and are not likely to cause any interference in nearby electronic equipment.
RF emissions – CISPR 11	Class B	The Model 9401/9402 Monitor is suitable for use in all establishments, including domestic establishments and those directly connected to the public low-voltage power supply network that supplies buildings used for domestic purposes.
Harmonic emissions IEC 61000-3-2	Class B	
Voltage fluctuations / flicker emissions	Complies	

Immunity Test	IEC 60601 Test Level	Compliance Level	Electromagnetic Environment Guidance
Electrostatic discharge (ESD) IEC 61000-4-2	+/- 6 kV contact +/- 8 kV air	+/- 6 kV contact +/- 8 kV air	Floors should be wood concrete or ceramic tile. If floors are covered with synthetic material, the relative humidity should be at least 30%.
Electrical fast transient/burst IEC 61000-4-4	+/- 2 kV for power supply lines +/- 1 kV for input/output lines	+/- 2 kV for power supply lines +/- 1 kV for input/output lines	Mains power quality should be that of a typical commercial or hospital environment.
Surge IEC 61000-4-5	+/- 1 kV differential mode +/- 2 kV common mode	+/- 1 kV differential mode +/- 2 kV common mode	Mains power quality should be that of a typical commercial or hospital environment.
Voltage Dips, short interruptions and voltage variations on power supply input lines IEC 61000-4-11	< 5% U_T (>95% dip in U_T) for 0.5 cycle. 40% U_T (60% dip in U_T) for 5 cycles. 70% U_T (30% dip in U_T) for 25 cycles. < 5% U_T (> 95% dip in U_T) for 5 seconds.	< 5% U_T (>95% dip in U_T) for 0.5 cycle. 40% U_T (60% dip in U_T) for 5 cycles. 70% U_T (30% dip in U_T) for 25 cycles. < 5% U_T (> 95% dip in U_T) for 5 seconds.	Mains power quality should be that of a typical commercial or hospital environment. If user of the Model 9401/9402 Monitor requires continued operation during power mains interruptions, it is recommended that the Model 9401/9402 Monitor be powered from an uninterruptible power supply or a battery.
Power frequency (50/60 Hz) magnetic field IEC 61000-4-8	3 A/m	3 A/m	Power frequency magnetic fields should be at levels characteristic of a typical location in a typical commercial or hospital environment.

NOTE: U_T is the A.C. mains voltage prior to application of the test level.

CARDELL MONITOR SERVICE MANUAL

Guidance and Manufacturer's Declaration – Electromagnetic Immunity

The Model 9401/9402 Monitor is intended for use in the electromagnetic environment specified below. The customer or the user of the Model 9401/9402 Monitor should insure that it is used in such an environment.

Immunity Test	IEC 60601 Test Level	Compliance Level	Electromagnetic Environment - Guidance
Conducted RF IEC 61000-4-6	3 Vrms 150 kHz to 80 MHz	3 Vrms	Portable and mobile RF communications equipment should be used no closer to any part of the Model 9401/9402 Monitor, including cables, than the recommended separation distance calculated from the equation applicable to the frequency of the transmitter. Recommended separation distance: $d = 1.2\sqrt{P}$ $d = 1.2\sqrt{P}$ 80 MHz to 800 MHz $d = 2.3\sqrt{P}$ 800 MHz to 2.5 GHz Where P is the maximum output power rating of the transmitter in watts according to the transmitter manufacturer and d is the recommended separation distance in meters. Field strengths from fixed RF transmitters, as determined by an electromagnetic site survey ^a , should be less than the compliance level in each frequency range. ^b Interference may occur in the vicinity of equipment marked with the following symbol: 
Radiated RF IEC 61000-4-3	3 V/m 80 MHz to 2.5 GHz	3 V/m	

NOTE 1 At 80 MHz and 800 MHz, the higher frequency range applies.

NOTE 2 These guidelines may not apply in all situations. Electromagnetic propagation is effected by absorption and reflection from structures, objects and people.

^a Field strengths from fixed transmitters, such as base stations for radio (cellular / cordless) telephones and land mobile radios, amateur radio, AM and FM radio broadcast and TV broadcast cannot be predicted theoretically with accuracy. To assess the electromagnetic environment due to fixed RF transmitters, an electromagnetic site survey should be considered. If the measured field strength in the location in which the Model 9401/9402 Monitor is used exceeds the applicable RF compliance level above, the Model 9401/9402 Monitor should be observed to verify normal operation. If abnormal performance is observed, additional measures may be necessary, such as re-orienting or relocating the Model 9401/9402 Monitor.

^b Over the frequency range 150 kHz to 80 MHz, field strengths should be less than 3 V/m.

Recommended Separation Distances Between Portable and Mobile RF Communications Equipment and the Model 9401/9402 Monitor

The Model 9401/9402 Monitor is intended for use in an electromagnetic environment in which radiated RF disturbances are controlled. The customer or the user of the Model 9401/9402 Monitor can help prevent electromagnetic interference by maintaining a minimum distance between portable and mobile RF communications equipment (transmitters) and the Model 9401/9402 Monitor as recommended below, according to the maximum output power of the communications equipment.

Rated maximum output power of transmitter (Watts)	Separation distance according to frequency of transmitter (Meters)		
	150 kHz to 80 MHz $d = 1.2\sqrt{P}$	80 MHz to 800 MHz $d = 1.2\sqrt{P}$	800 MHz to 2.5 GHz $d = 2.3\sqrt{P}$
0.01	0.12	0.12	0.23
0.1	0.38	0.38	0.73
1	1.2	1.2	2.3
10	3.8	3.8	7.3
100	12	12	23

For transmitters operating at a maximum output power not listed above, the recommended separation distance d in meters can be estimated using the equation applicable to the frequency of the transmitter, where P is the maximum output power rating of the transmitter in watts according to the transmitter manufacturer.

NOTE 1 At 80 MHz and 800 MHz, the separation distance for the higher frequency range applies.

NOTE 2 These guidelines may not apply in all situations. Electromagnetic propagation is affected by absorption and reflection from structures, objects and people.

5. SYMBOLS

The following is a summary of all symbols used on the monitor and accessories. Symbols may occur on the product or on its packaging.

Units may display the following symbols:



Alternating Current



CAUTION: Before using, read instructions included.



The CE Mark signifies the device has met all essential requirements of European Medical Device Directive 89/336EEC.



This symbol appears here instead of on the unit.
The first two digits of the unit's serial number indicate the year of manufacture in the 21st century.



Indicates this monitor is subject to the Waste Electrical and Electronic Equipment Directive in the European Union.



SYMBOLS (CONT.)

IPX1

Protection against ingress of water.



Indicates protection against the effects of the discharge of a cardiac defibrillator. Patient connections are Type BF and protected against defibrillation.



Equipotentiality Ground Post



NIBP Hose and Cuff Connector

SpO₂

Pulse Oximeter Probe Connector

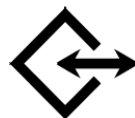

Two way Communication Port
RS232 Interface Connector

SYMBOLS (CONT.)

These symbols appear on the front panel in place of text.



ON/STANDBY – Turns “ON” the Monitor’s display.



SILENCE/RESET



START/STAT

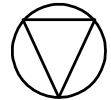

CANCEL



CYCLE TIME

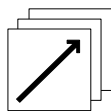

HISTORY

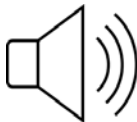

VOLUME

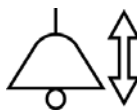

ALARM LIMITS

SYMBOLS

(CONT.)



ARROW UP



ARROW DOWN



Bar graph display of SpO₂ signal strength.

 **BPM**

Pulse Rate Display

Large Cuff

A lighted LED to indicate NIBP operating with “Child” size cuff or larger.

Small Cuff

A lighted LED to indicate NIBP operating with “Neonatal” size cuff.

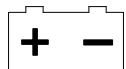

A tri-colored LED used to indicate the status of the monitors power source.

SYMBOLS (CONT.)

These symbols appear on the battery pack in place of text.



Recycling suggested (see General Notes).

These symbols appear on the packaging in place of text.



Symbol used to indicate where Relative Humidity information concerning storage and transport can be located.



Symbol used to indicate the minimum and maximum storage and transport Temperatures.

This symbol appears on the printer in place of text.



WARNING: Before removing, read instructions located in User's Manual.

This page is intentionally left blank

6. MONITOR CONTROLS

FRONT PANEL



Figure 2: Front Panel View

DIGITAL DISPLAY AND INDICATORS

SYSTOLIC mmHg	Red colored LEDs indicate the Systolic pressure measurement in mmHg.
DIASTOLIC mmHg	Red colored LEDs indicate the Diastolic pressure measurement in mmHg.
MAP mmHg	Red colored LEDs indicate the Mean Arterial Pressure in mmHg (if enabled).
%SpO₂ (Model 9402)	Green colored LEDs indicate the %SpO ₂ value.

BPM

Red colored LEDs indicate the Pulse Rate in BPM (beats per minute).



Green colored LEDs provide a visual indication of the SpO₂ signal strength in a bar graph form (Model 9402).

LARGE CUFF

A yellow LED indicator used to inform the user that the NIBP is operating with a Child size cuff or larger.

SMALL CUFF

A yellow LED indicator used to inform the user that the NIBP is operating with a Neonatal size cuff.

Ready

Message Window area used to display various messages that aid the user in monitor operation.

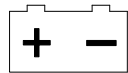

A tri-colored visual indicator used to display the status of the power source and battery condition.

The status of the LED is:

- GREEN = Monitor is connected to an AC wall outlet.
- ORANGE = In Use on Battery
- RED = Battery Low or Dead Battery



A Yellow LED visual indicator used along with the SILENCE/RESET pushbutton to display the status of the Audio Alarm Silence feature.

The status of the LED is:

- “ON” continuously = 2 Minute Audio Silence
- Flash one second “ON”/one second “OFF” = Permanent Audio Alarm Silence

FRONT PANEL CONTROLS



Figure 3: Front Controls



ON/STANDBY:

Press once, turns “ON” the CARDELL Monitor’s display (if it was OFF).

Press again will place the monitor into Standby.



SILENCE/RESET:

When pressed during an active patient alarm, silences the audio portion of that alarm for fifteen (15) seconds.

When pressed during an active equipment alarm, the alarm condition shall be acknowledged along with the audio and visual shall be removed.

Used to enable and disable the two (2) Minute Audio Off or Permanent Audio Off feature.

Allows the user to clear NIBP and SpO₂ messages from the front panel display.



START/STAT:

START:

Initiates a blood pressure measurement in the Manual Mode or begins the selected Automatic Cycle.

STAT:

Starts a series of NIBP measurements (press and hold for two (2) seconds). Continues for five minutes.

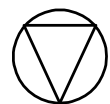

CANCEL:

Cancels any active blood pressure function and immediately deflates the cuff.

Press and hold for two (2) seconds to change between Large Cuff and Small Cuff NIBP Modes.

Also used to cancel out of a menu and return to "Ready".



CYCLE TIME:

Allows the user to select a time interval for Automatic blood pressure measurement.

Automatic measurement cycles of 1, 2, 3, 4, 5, 10, 15, 30, 60, or 90 minutes may be chosen.

Also used to read the monitor's current time (press and hold for two (2) seconds).

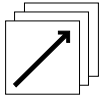

HISTORY:

Allows the user to review stored patient readings.

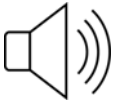

VOLUME:

Used to set the volume level of the Alarms and the SpO₂ Beep (Model 9402). Use the Up and Down Arrows to change.

Also used to adjust the brightness of the front panel displays (press and hold for two (2) seconds).



ALARM LIMITS:

Allows the user to enter and set the monitor's Alarm Limits.



ARROW UP:

Allows forward Adjustment (Auto Cycle, History, Inflation Pressure, Limits and Monitor Configuration).

Press to cycle through menu selections or press and hold for quicker advance.



ARROW DOWN:

Allows backwards Adjustment (Auto Cycle, History, Inflation Pressure, Limits and Monitor Configuration).

Press to cycle through menu selections or press and hold for quicker advance.

NEXT

The **HISTORY** and **VOLUME** pushbutton keys have been programmed to allow the user to advance forward to the **next** selection in the Monitor Configuration menu.

PREVIOUS

The **CYCLE TIME** and **ALARM LIMITS** pushbutton keys have been programmed to allow the user to advance backwards to the **previous** selection in the Monitor Configuration menu.

INFRARED (IR) DATA PORT

An Infrared (IR) output port, located on the bottom panel of the monitor's front cover, is available to print the NIBP, %SpO₂ and Temperature History data to the optional external printer or other data collection device(s).

REAR PANEL

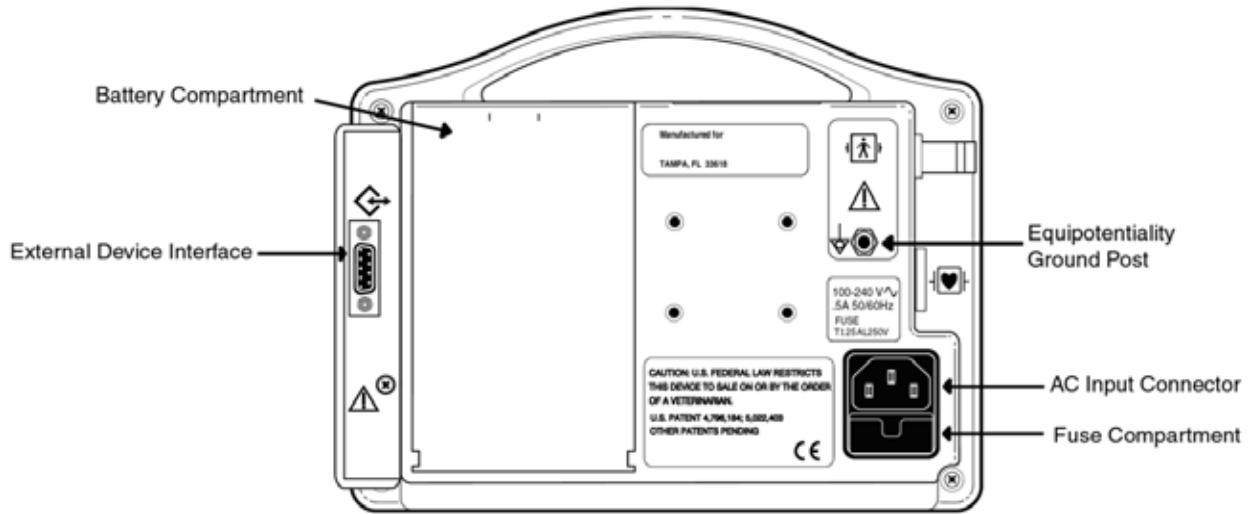

Figure 4: Rear Panel View

AC LINE POWER CONNECTOR

Receptacle for the AC power cord.

FUSE COMPARTMENT

The power input receptacle incorporates dual fuses located in the hot and neutral lines.

BATTERY COMPARTMENT

The CARDELL Monitor is equipped with a 7.2 Volt, 3700 mAh battery pack that, when fully charged, is capable of taking 100 NIBP readings when the monitor is set in the 5-minute Automatic Mode.

NOTE:
The serial number label is located on the bottom of the monitor.

EXTERNAL DEVICE INTERFACING

The CARDELL Monitor is available with an optional DB9 RS232 serial output connector that is used to interface to the Citizen CMP-10 Mobile Printer or another serial printing device.

LEFT SIDE VIEW

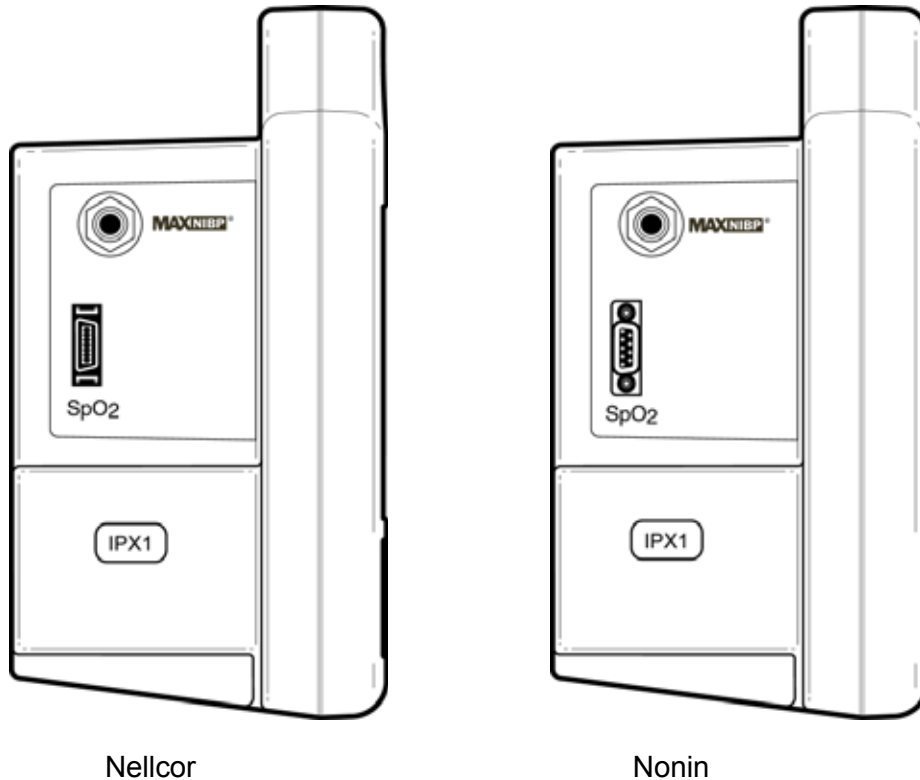

Figure 5: Left Panel Views

MAXNIBP®

CUFF HOSE CONNECTION

The six (6) foot, Inflation Hose is connected to the monitor where the MAXNIBP logo is located as shown in Figure 5. The hose must be connected to the cuff prior to use.

VET SpO₂ SENSOR CONNECTION

(Model 9402)



Connect the sensor cable in this receptacle for SpO₂ monitoring.

7. MONITOR CONFIGURATION

The Monitor Configuration section allows the user to configure the CARDELL Monitor. Once entered, the user can:

- Review the monitor's internal Software Revisions
- Set the Operating Language
- Make selections for Audio Alarms
- Choose to display the MAP value
- Set the SpO₂ Alarm Delay (Nellcor)
- Set the Date
- Set the Time
- Set Daylight Saving Time Option
- Perform System Checks (Refer to CONFIGURATION MODE TESTS)
 - All LEDs "ON" Check
 - +12 Volt Power Supply Check
 - Manometer Mode
 - Pneumatic Pressure Check

ENTERING THE MONITOR CONFIGURATION MENU

To enter the monitor's Configuration Menu, press and hold the VOLUME  and ALARM LIMITS  pushbutton keys while the monitor is being turned "ON" .

Once in the menu, use one of the *NEXT* (HISTORY / VOLUME) or *PREVIOUS* (CYCLE TIME / ALARM LIMITS) programmed pushbutton keys to advance onto the next or go back to the previous parameter in the Configuration Menu.

NOTE:

While in the Configuration Menu, if no pushbutton is pressed within 60 seconds, the monitor will automatically save all changes made and exit the Monitor Configuration menu. The Message Window will briefly display "Saving" and return to the "Ready" mode.

SAVING YOUR CHANGES

When you have completed configuring the monitor, press the CANCEL pushbutton to exit and lock in your selection(s). The Message Window will briefly display "Saving" and return to the "Ready" mode.

SOFTWARE REVISIONS

The CARDELL Monitor displays the current software revision of its operating system and that of the internal modules being used inside. The software versions are displayed in the following order:

Software Module	Message Window
CARDELL Control Board	VER X.X
Boot Loader	BootX.XX
Power Supply PIC Processor	PIC X.X
CAS NIBP Module	ND X.X
Nellcor SpO ₂ Module ⁽¹⁾	NEL X.X
Nonin SpO ₂ Module	NON XX

Table 3: **Software Revisions**

Use the ARROW UP or ARROW DOWN pushbuttons to view the messages.

Press one of the *NEXT* programmed pushbutton keys to advance onto the next menu or use the CANCEL pushbutton to Save your changes and exit to the “Ready” mode.

SETTING THE LANGUAGE

The CARDELL Monitor can operate in one (1) of nine (9) languages: English, German, French, Italian, Spanish, Dutch, Swedish, Portuguese or Norwegian.

To configure the monitor’s operating language, first enter the Monitor Configuration menu. Refer to Page 39, ENTERING THE MONITOR CONFIGURATION MENU.

Once in the menu, use one of the *NEXT* programmed pushbutton keys until the Message Window displays the current language being used.

Use the ARROW UP or ARROW DOWN pushbuttons to make your selection.

Press one of the *NEXT* programmed pushbutton keys to advance onto the next menu or use the CANCEL pushbutton to exit to the “Ready” mode.

(1) Available SpO₂ Oximetry is either Nellcor or Nonin. In the Model 9401 monitor, this message is skipped.

AUDIO ALARM SILENCE (SILENCE/RESET Pushbutton)

The CARDELL Monitor's SILENCE/RESET pushbutton can be configured to have the audio associated with patient alarms set to one of three selections. The selections are:

- 2-Minute Audio Alarm Silence (Default)
- Permanent Audio Alarm Silence
- Alarm Limits Off

To configure the alarms, first enter the Monitor Configuration menu. Refer to Page 39, ENTERING THE MONITOR CONFIGURATION MENU.

Once in the menu, use one of the *NEXT* programmed pushbutton keys until the Message Window displays the current value of the Audio Alarms menus.

Use the ARROW UP or ARROW DOWN pushbuttons to make your selection.

Press one of the *NEXT* programmed pushbutton keys to advance onto the next menu or use the CANCEL pushbutton to exit to the "Ready" mode.

2-MINUTE AUDIO ALARM SILENCE

When the monitor is configured for the 2-Minute Audio Alarm Silence setting, use the SILENCE/RESET pushbutton to "enable or disable" audio alarms for a two (2) minute period. The SILENCE visual indicator, located on the front panel of the monitor will be illuminated constantly and the message "2Min Aud" will be displayed on the Message Window as a reminder when enabled. At the end of two (2) minutes, the monitor will automatically exit the 2-Minute Audio Alarm Silence setting and return to normal operation.

During a two-minute silence period, if an alarm (patient or equipment) occurs, except for Low Battery and Dead Battery, the audio alarm remains silenced for the remainder of the two-minutes and only a visual indicator is provided.

PERMANENT AUDIO ALARM SILENCE

When the monitor is configured to the Permanent Audio Alarm Silence setting, use the SILENCE/RESET pushbutton to "enable or disable" audio alarms. The SILENCE visual indicator, located on the front panel of the monitor will flash at a rate of one (1) second "ON" and one (1) second "OFF" and the message "Perm Aud" is displayed on the Message Window as a reminder when enabled.

During a permanent audio alarm off period, if an alarm (patient or equipment) occurs, except for Low Battery and Dead Battery, the audio alarm remains silenced and only a visual indicator is provided.

ALARM LIMITS OFF

When the monitor is configured to the Alarm Limit Off setting, all alarms associated with patient alarms are “OFF”. This mode is useful for spot check applications or if the monitor is being moved from patient to patient and the user may not want to be disturbed by any audible alarms.

The SILENCE visual indicator, located on the front panel of the monitor will flash at a rate of two (2) seconds “ON” and two (2) seconds “OFF” and the message “Alrm Off” will be displayed on the Message Window as a reminder when enabled.

During an alarm limit off period, if an equipment alarm occurs, except for Low Battery and Dead Battery, the audio alarm remains silenced and only a visual indicator is provided.

MAP VALUE ENABLE / DISABLE

During a blood pressure reading, the user can elect to display or not to display the MAP value.

Should it need to be changed, first enter the Monitor Configuration menu. Refer to Page 39, ENTERING THE MONITOR CONFIGURATION MENU.

Once in the menu, use one of the NEXT programmed pushbutton keys until the Message Window displays the monitor’s current setting for the MAP value “MAP On” or “MAP Off”.

Use the ARROW UP or ARROW DOWN pushbuttons to make your selection.

NOTE:

When “MAP Off” is selected, MAP values are omitted from History Display and Printing as well. All alarms associated with MAP values are also disabled.

Press one of the *NEXT* programmed pushbutton keys to advance onto the next menu or use the CANCEL pushbutton to exit to the “Ready” mode.

SET THE SpO₂ ALARM DELAY

(Nellcor SpO₂ only)

The delay time until an alarm is generated for %SpO₂ and Pulse Rate can be configured to be either zero (0) seconds “Delay 0S” or ten (10) seconds “Delay10S”. The default value used by the CARDELL Monitor is ten (10) seconds.

Should it need to be changed, first enter the Configuration menu. Refer to Page 39, ENTERING THE MONITOR CONFIGURATION MENU.

Once in the menu, use one of the NEXT programmed pushbutton keys until the Message Window displays the monitor’s current setting for the SpO₂ Alarm Delay.

Use the ARROW UP or ARROW DOWN pushbuttons to make your selection.

Press one of the NEXT programmed pushbutton keys to advance onto the next menu or use the CANCEL pushbutton to exit to the “Ready” mode.

SETTING THE DATE

The CARDELL Monitor’s Date value is set at the factory. Should it need to be changed, enter the Monitor Configuration menu and use one of the NEXT programmed pushbutton keys until the Message Window displays the monitor’s date using the following format: “DDMMYY”. Where DD = Day of the Month, MMM = Month of the Year (Jan, Feb, etc.) and YY = Last 2 digits of the year (2002 is displayed as 02). The flashing parameter indicates the parameter that can be changed.

Use the ARROW UP or ARROW DOWN pushbuttons to make your selection. Press one of the NEXT programmed pushbutton keys to advance to the next parameter to set within the Date menu.

Press one of the NEXT programmed pushbutton keys to advance onto the next menu or use the CANCEL pushbutton to exit to the “Ready” mode.

SETTING THE TIME

The CARDELL Monitor’s Time value is set for Eastern Time and is set at the factory. Should it need to be changed, enter the Monitor Configuration menu and use one of the NEXT programmed pushbutton keys until the Message Window displays the monitor’s time using the following format: “HH:MM”. Where HH = Hour of the Day (0 – 23) and MM = Minute of the Hour (0 – 59). The flashing parameter indicated the parameter that can be changed.

Use the ARROW UP or ARROW DOWN pushbuttons to make your selection. Press one of the NEXT programmed pushbutton keys to advance to the next parameter to set within the Time menu.

NOTE:

Altering the Date and Time will affect the History readings, but not erase them.

Press one of the NEXT programmed pushbutton keys to advance onto the next menu or use the CANCEL pushbutton to exit to the “Ready” mode.

DAYLIGHT SAVING TIME OPTION

The CARDELL Monitor can be configured to automatically respond to time changes associated with Daylight Saving Time. The monitor can be configured to one of five Daylight Saving Time Option settings. They are:

- **DST OFF** Daylight Saving Time is “OFF”. The user is responsible for changing the time if needed. This is the default setting for the CARDELL Monitor.
- **DST N AM** Daylight Saving Time “North America”. Use this setting and the monitor will automatically *add* one (1) hour the first Sunday in April at 2 a.m. and *subtract* (1) hour the last Sunday in October at 2 a.m.
- **DST EU 1, 2, 3** Daylight Saving Time “European Union”.

In the European Union, Daylight Saving Time begins and ends at 1 a.m. Universal Time (Greenwich Mean Time). It starts the last Sunday in March, and ends the last Sunday in October. In the EU, all time zones change at the same moment.

Select EU 1 if the monitor will be located in Ireland, Portugal or the United Kingdom. Select EU 3 for Finland. EU 2 can be used for all remaining countries within the European Union.

<p style="text-align: center;">NOTE:</p>

<p>Enabling Daylight Saving Time will affect the History readings, but not erase them.</p>
--

Should it need to be changed, first enter the Configuration menu. Refer to Page 39, ENTERING THE MONITOR CONFIGURATION MENU.

Once in the menu, use one of the NEXT programmed pushbutton keys until the Message Window displays the monitor’s current setting for Daylight Savings Time.

Press one of the NEXT programmed pushbutton keys to advance onto the next menu or use the CANCEL pushbutton to exit to the “Ready” mode.

8. EXTERNAL DEVICE INTERFACING

OVERVIEW

The CARDELL Monitor is capable of interfacing to an external Serial printer.

WARNING:

The CARDELL Monitor has been tested with the Citizen CMP-10 Mobile printer to comply with IEC 60601-1-1 and is the only printer that is recommended to be used with the monitor. If another printer is to be used, the user must read the Warning on Page 18 under LEAKAGE CURRENT TEST and follow the guidance given.

RS232

The CARDELL monitor uses the optional DB9 connector to interface to the Citizen CMP-10 Mobile printer using the cable supplied with the printer. The connector information provided in this section is made available to allow the user the ability to print the monitor's History data to an external serial printer. Refer to Figure 6 and Table 4 for connection information.

Refer to Section 15, SPECIFICATIONS for Serial Interface information.

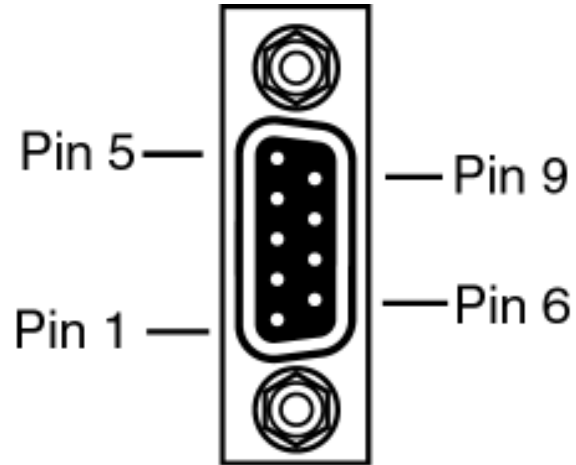

Figure 6: **DB9 Male Connector Pin Layout**

Pin Number	Signal Description
1	No Connection
2	Serial Receive In
3	Serial Transmit Out
4	No Connection
5	Isolated Ground
6	No Connection
7	No Connection
8	No Connection
9	No Connection

Table 4: **DB9 Pin Out**

9. ROUTINE MAINTENANCE

CLEANING

CLEANING OVERVIEW

WARNING:

Do not, under any circumstances, perform any testing or maintenance on the monitor while the monitor is being used to monitor a patient.

CAUTION:

Unplug the monitor from the AC power source and remove all the accessories from the monitor before cleaning. The monitor must be turned off and not running on the internal battery. Never clean the monitor when it is being operated.

THE MONITOR

On a daily basis, examine the monitor's case for any damages and check the AC power cord for bent or broken prongs, cracks or fraying. Neither the monitor nor the power cord should be used if damaged. If any damage is noted, contact the appropriate service personnel.

CAUTION:

Do not spray any water or cleaning solution directly onto the monitor.

As needed, clean the monitor using a soft cloth dampened with a mild dishwashing detergent solution and gently rub the soiled area until clean. Use a clean soft cloth to dry the monitor. Do not use abrasive cleaners on the monitor. Do not use either isopropyl alcohol or solvent to clean the monitor. Use of these cleaners can cause damage to the monitors' surface. Do not immerse the monitor or power cord in the cleaning solution.

When necessary, the monitor surfaces may be disinfected using a soft cloth saturated with a 10% (1:10) solution of chlorine bleach in tap water. When all of the surfaces have been disinfected, wipe the entire surface of the monitor using a soft cloth dampened with fresh water to remove any trace amounts of residue and/or fumes.

NOTE:

Thoroughly wipe off any excess cleaning solutions. Care should be taken to prevent water or cleaning solution to run into connector openings or crevices.

THE DISPLAY

CAUTION:

Use care when cleaning the display. Scratches may occur.

Occasionally, as needed, clean the display window using a soft, lint-free cloth sprayed with an alcohol free glass cleaner. Do not use either isopropyl alcohol or solvent to clean the display. Use of these cleaners can cause damage to the display. The use of paper towels is not recommended as it may scratch the surface.

CUFFS

Prior to each patient use, inspect the blood pressure cuff for damage.

NOTE:

Refer to product packaging for additional Cleaning and Disinfecting Instructions were applicable.

CAUTION:

If the cuff should become grossly contaminated with blood or other bodily fluids, it should be discarded.

NOTE:

CAS does not recommend submersion of the cuff. Liquid should not be permitted to enter the cuff bladder because instrument damage may occur. The cuff should be allowed to thoroughly dry before use.

TUFF-CUFF

As necessary, clean the cuff using a soft cloth dampened with a 70% Isopropyl Alcohol solution.

SAFE-CUFF

As necessary, clean the cuff using a soft cloth dampened with a soap, water-based detergent or chlorinated disinfectant solution. Do not use alcohol.

SOFTCHECK

These cuffs are designed for single patient use, and are not to be reprocessed.

ULTRACHECK

As necessary, for normal cleaning with mild detergents / dilute bleach solution (1-2%), wipe the cuff with the cleaning solution, rinse with water and dry.

PNEUMATIC TUBING

CAUTION:

If the hose should become grossly contaminated with blood or other bodily fluids, it should be discarded.

NOTE:

CAS does not recommend submersion of the hose. Liquid should not be permitted to enter the hose because instrument damage may occur. The hose should be allowed to thoroughly dry before use.

Prior to each patient use, inspect the NIBP Inflation Hose for proper connection, cracks and kinks. As necessary, clean the pneumatic tubing using a soft cloth dampened with a germicidal solution.

PRINTER

When the printer becomes dirty, wipe with a soft dry cloth. For extreme dirt buildup, soak a cloth with mild detergent, wring well and wipe. Dry by wiping with a soft dry cloth.

CAUTION:

Before cleaning the printer, disconnect the AC adapter from the printer. Do not use volatile chemicals such as thinner, benzene, etc. Never wet the inside of the printer mechanism.

Refer to the printer User's Manual for more information.

SpO₂ INTERCONNECT CABLE

Prior to each patient use, inspect the SpO₂ Interconnect cable for damage. As necessary clean the cable using a soft cloth dampened with a germicidal solution.

SpO₂ SENSORS

(Reusable)

As necessary, the sensor may be surface cleaned by wiping it with a 70% isopropyl alcohol pad. Allow the sensor to dry prior to placement on a patient.

CAUTION:

Do not soak or immerse the sensor or its cable in any liquid solution. Do not attempt to sterilize.

Refer to the Directions For Use pamphlet enclosed with each sensor for more information.

PNEUMATIC PRESSURE CHECK

A check of the monitor's pneumatic pressure system should be performed every six (6) months.

SAFETY CHECKS

The following Safety Checks should be performed at least every twelve (12) months by a qualified service technician.

- Inspect the equipment for mechanical and functional damage.

SYSTEM CHECKS

The following System Checks should be performed at least every twelve (12) months by a qualified service technician.

- All LEDs "ON" Check
- +12 Volt Power Supply Check
- System Pressure Checks
- Overpressure Check
- Oximetry Calibration Check
- Chassis Leakage

The following Electrical Safety Check should be performed any time the case is opened or patient isolation is in question.

- Hypot

BATTERY

CAS Medical Systems recommends replacing the monitor's battery every two (2) years.

When the CARDELL Monitor is going to be stored for two (2) months or more, remove the battery prior to storage. To remove the battery, refer to Section *REPLACING THE MONITOR BATTERY*.

If the CARDELL Monitor has been stored for more than thirty (30) days, charge the battery as described in Section *BATTERY CHARGE*. A fully discharged battery requires four (4) hours to receive a full charge. The battery is being charged whenever the monitor is connected to an AC wall outlet.

10. TROUBLESHOOTING

SYSTEM TROUBLESHOOTING

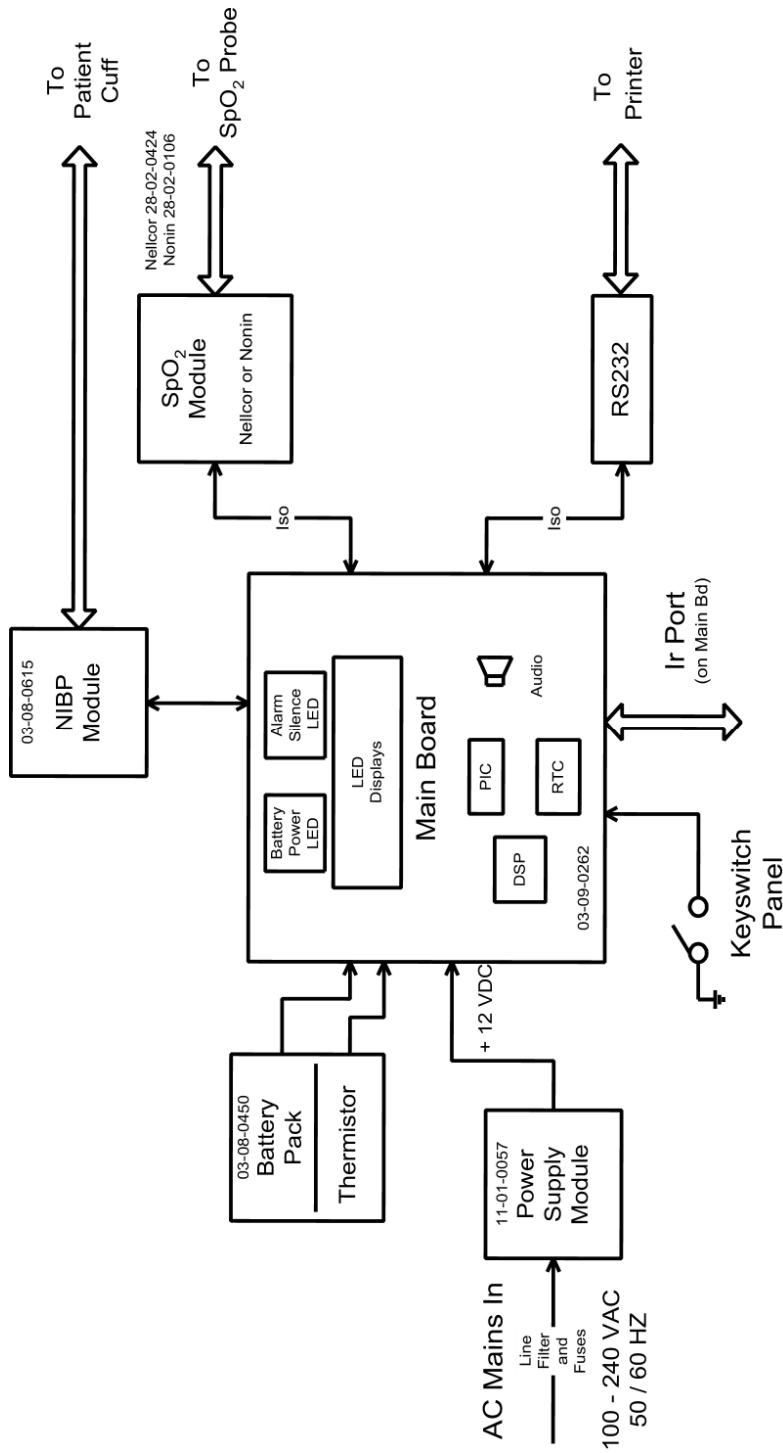

Figure 7: Overall Block Diagram

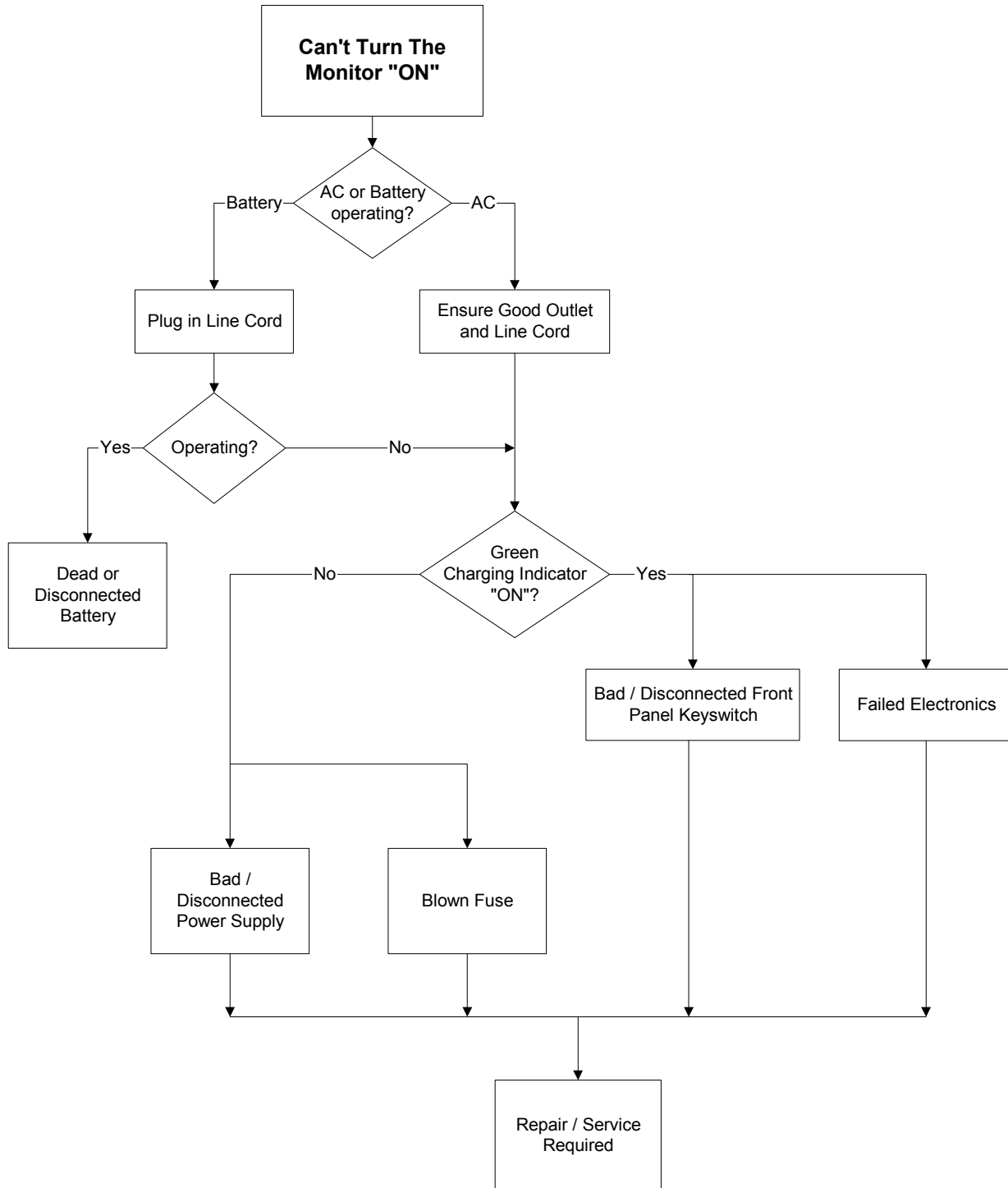

Figure 8: No Monitor Power

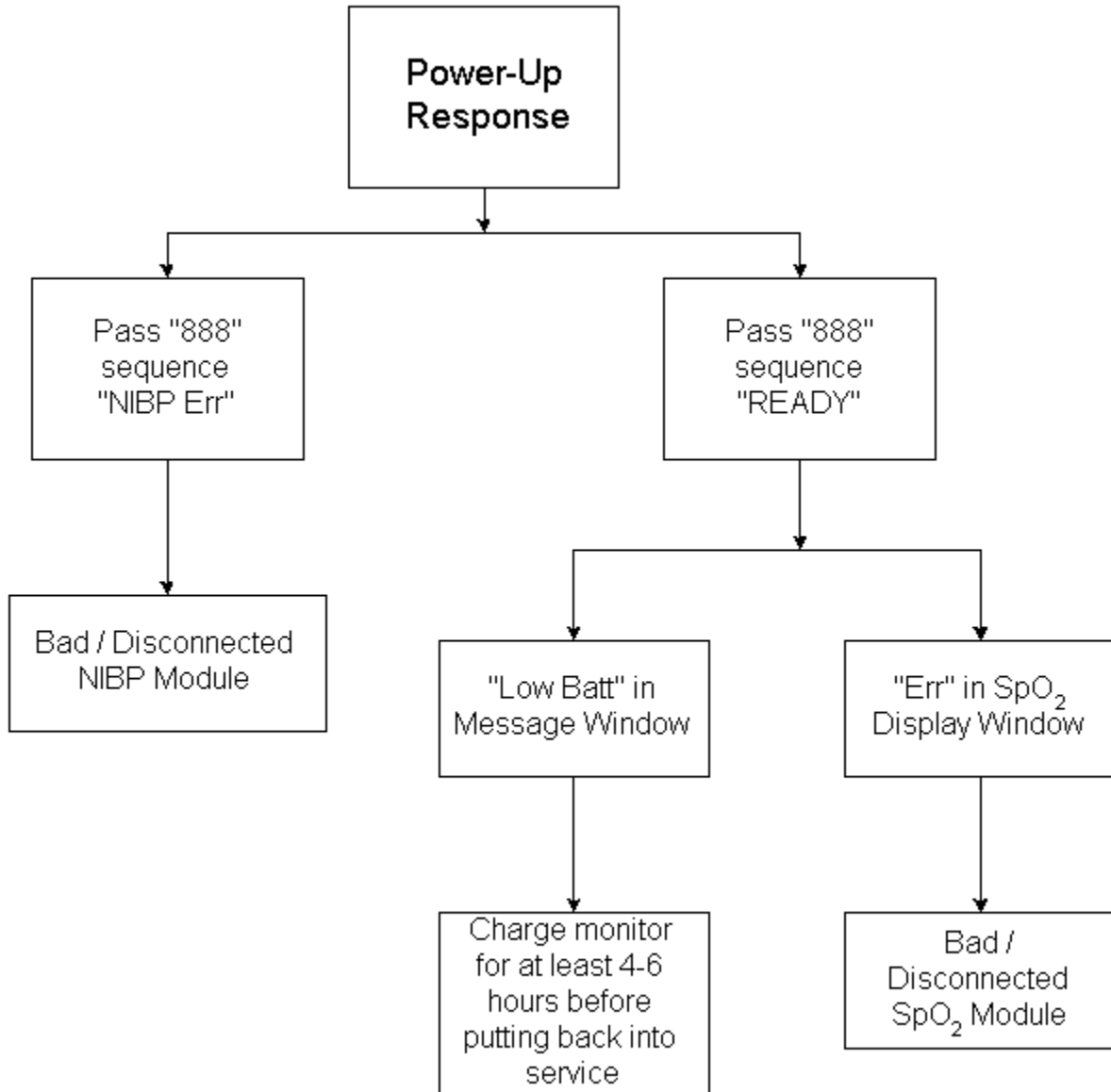

Figure 9: **Power-Up Response**

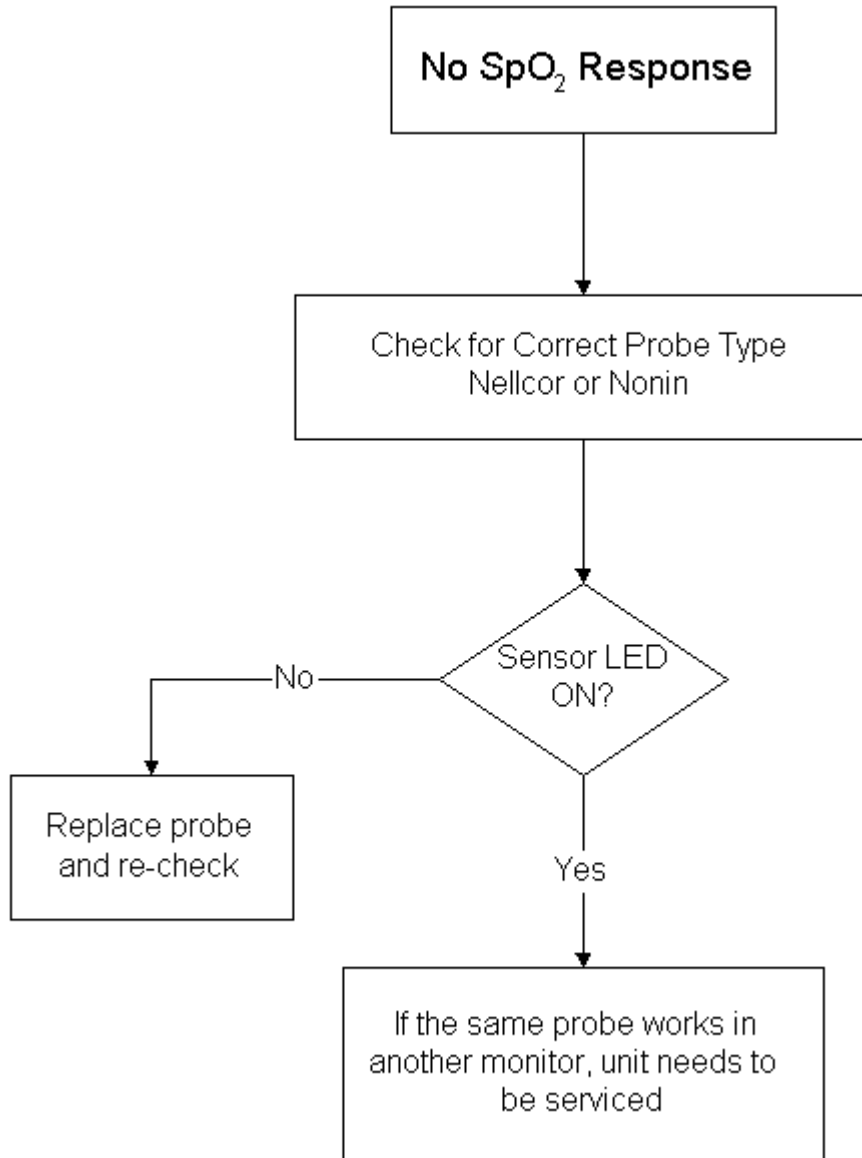

Figure 10: **SpO₂ Troubleshooting**

THEORY OF OPERATION

The CARDELL Monitor's Main Control Board provides the following functions for the operation of the monitor.

- Power Supplies
- Battery Charger
- Supervisor Microcontroller (Microchip PIC 16F73)
 1. Indicator LEDs
 2. Power Smart Module
 3. Power ON/OFF and Reset to Digital Signal Processor Controller
 4. Monitor ON/OFF
 5. Communication with Digital Signal Processor Controller
 6. Monitor Battery Charger and Battery conditions
- Digital Signal Processor Controller (Motorola DSP 56F827)
 1. SpO₂ Monitoring
 2. Blood Pressure Monitoring
 3. Keypad Monitoring
 4. Indicator LEDs and Displays
 5. Real-Time Clock
 6. Alarms
 7. Serial Interface

POWER SUPPLIES

The input to the Main Control Board comes from either the DC input (J1) or the Battery Input (J2). A Control chip (U6) is responsible for selecting the monitor's main power source. The DC input always takes priority over the Battery.

Battery	7.2 Volts @ 4.0 Ahr (TP7 to TP33)
DC	12 Volts @ 28 Watts (TP28 to TP29)

There are several supplies that are generated for internal use.

+Vpic TP5 The power supply for the Microchip PIC16F73 (U5), the Supervisor of the Main Control Board.

The DC input or the Battery input, if there is no DC present, goes into a voltage regulator (U4) to supply the +3.3 volts.

+5V TP1 Power supply voltage for the main Analog and Digital circuitry. The DC input or the Battery input, if there is no DC present, goes into a switching regulator (U1) to supply +5 volts. The regulator is turned on and off by the Microcontroller (U5).

+3.3V TP2 Chip I/O supply voltage for the DSP Controller (U20).
The +5 volts output of the switching regulator (U1) goes into a voltage regulator (U2) to supply the +3.3 volts.

+2.5V TP3 Core operating voltage for the DSP Controller (U20).
The +5 volts output of the switching regulator (U1) goes into a voltage regulator (U3) to supply the +2.5 volts.

+5V_ISO2 TP8 Isolated power supply for the SpO₂ circuit.
The +5 volts output of the switching regulator (U1) goes into a dc-dc converter (U9) to supply +7 volts. The converter provides an isolation voltage of 2.5KV. The dc-dc converter is turned on and off by the DSP controller (U20) and transistor (Q7). The output of the converter feeds a +5 volt regulator (U22) that provides voltage for the SpO₂ board.

+5VCRG TP6 Power supply for the Battery Charger.
The DC input goes into a voltage regulator (U7) to supply the +5 volts.

+VND TP4 Power supply for the Blood Pressure pump.
The DC input or the Battery input, if there is no DC present, goes into a voltage regulator (U27) to supply the +6 volts. The voltage regulator is turned on and off by the DSP controller (U20) and transistors (Q16 and Q17).

BATTERY CHARGER

The battery charging is controlled by U8.

SUPERVISOR MICROCONTROLLER

The Microchip PIC16F73 (U5) is the supervisor of the Main Control Board. The controller has 4K of program flash, 192 bytes of data memory and operates from an external 153.6KHz crystal. The Microcontroller has 22 I/O's, 3 timers, 2 PWM/capture/compare modules, UART, SPI, and five (5) 8bit analog-to-digital channels.

Indicator LED's

LED1 is the power/low battery/charging indicator that is controlled by an output port of the Microcontroller (U5).

Power Smart Module

The Power Smart Module option comes into the Main Control Board at J2 (pins 2 and 3). The Power Smart Module is read by the Supervisor (U5 pins 25 and 26) then sent to the DSP (U20) thru the SPI port.

Power ON/OFF and Reset to Digital Signal Processor Controller

The Power switch comes into the Main Control Board at keypad connector J6. It is read as an input pin to the Supervisor (U5 pin 21).

The Supervisor has an output pin (U5 pin 7) that controls the reset to the DSP (U20).

Monitor ON/OFF (+5V ENABLE)

The monitor turning on and off is control by an output pin of the Supervisor (U5 pin 11) and associated components Q1 and Q2.

Communication with Digital Signal Processor Controller

The Supervisor (U5) has two-way communication to the DSP (U20) using a dedicated SPI line.

Monitor Battery Charger and Battery Conditions

The DC input and Battery inputs are read by two analog to digital converter of the Supervisor (U5 pins 2 and 3). The results of these signals are used to control the Low and Dead Battery conditions of the monitor and the status of the front panel Power / Charging LED (LED 1).

Two output lines from the Battery Charger Control chip (U8) are read by the Supervisor (U5 pins 23 and 24). The information from these pins informs the Supervisor the status of the charging condition (fast charge, trickle charge or hold off). All of the information is sent from the Supervisor to the DSP (U20) thru the SPI port.

DIGITAL SIGNAL PROCESSOR CONTROLLER

The Motorola DSP56F827, is Digital Signal Processor (DSP U20) and is the Main Controller of the CARDELL Monitor. The controller has 64K of program flash, 4K of data flash, 1K program ram, 4K of data ram and operates off an external 4 MHz crystal. The DSP features are PLL, 2 SPI ports, TOD, watchdog timer, quad timer, 16 dedicated I/O, 48 shared I/O, 64 muxed I/O, interrupt controller, 8 programmable chip selects and 32 external bus signals.

SpO₂ Monitoring

The SpO₂ Module is an option that is plugged into the Main Control Board, J3 for Nellcor and Nonin. The isolated power supply for the SpO₂ Module circuit (+5V_ISO2) is controlled by an output pin of the DSP (U20 pin 37). The Module is read by the DSP (U20) thru the serial port (TXD2 and RXD2) and associated components (U10, Q9, Q10, ISO1 and ISO2). The power is turned off when the SpO₂ option is not installed.

Blood Pressure Monitoring

The Blood Pressure Module is plugged into J4 of the Main Control Board. The power (+VND) of the Blood Pressure Module is controlled by an output pin of the DSP (U20 pin 36). The Blood Pressure Module is read by the DSP (U20) thru the serial port (TXD1 and RXD1).

Keypad Monitoring

The keypad comes into the Main Control Board at J6. There are eight keys are read as inputs by the DSP (U20 pins 116 - 124). The keys are normally high and active low when the switch is pressed.

Indicator LED'S and Displays

U11, U13, U14, U15 and U16 are seven segment LED driver IC's that are controlled thru the SPI port of the DSP (U20). They are used to display Systolic, Diastolic, MAP, %SpO₂, BPM, SpO₂ bar graph, LARGE CUFF led, SMALL CUFF led, Silence led and the two slash led's. U12 is an eight character smart alphanumeric display (Message Window) that is driven by the DSP (U20) directly.

Real-Time Clock

The real-time clock (U21) is controlled by the DSP (U20) thru the SPI port. The part has it own battery and internal crystal. The battery can be replaced separately when needed.

Alarms

The alarms circuit has an audio attenuator (U23), an amplifier (U24) and a speaker (LS1). The sound is controlled by the DSP (U20).

Serial Interface

The serial input/output goes into the Main Control Board on J10. The serial port is controlled by the DSP (U20).

ERROR MESSAGES

The CARDELL Monitor displays a variety of messages to aid the user in monitor operation. If a troubleshooting message is displayed during a measurement, follow the actions listed to correct the situation.

If the monitor does not turn on, or exhibits a flashing display and failure to operate, the battery is most likely below the Dead Battery point. Connect the monitor to an AC wall outlet and allow it to charge for four (4) hours.

If the monitor is in need of repair, it must be referred to the appropriate service personnel. Service performed by unauthorized personnel could be detrimental to the monitor and will void the warranty. For service, contact CAS Medical Systems, Inc.

SpO₂ USER MESSAGES

(Model 9402)

If the accuracy of any measurement does not seem reasonable, first check the patient's vital signs by an alternate method.

NOTE:

The SpO₂ probe must be kept as motionless as possible to make a proper determination. Use the SpO₂ strength bar graph to determine if a strong rhythmic pulse signal is present.

When no oximeter probe is attached to the monitor, the %SpO₂ window and signal strength window will be blank. When no SpO₂ pulse data is available, the monitor will display the last NIBP pulse.

When the probe is connected to the monitor, but is off of the patient, the message “-“ is displayed in the %SpO₂ and Pulse Rate windows. The Message Window flashes the message “Prb OFF” and three (3) audio “beeps” are heard every twenty-five (25) seconds.

Press the SILENCE/RESET pushbutton. The monitor silences the audible alarm tone, but the message remains.

If the message “Prb” should appear in the %SpO₂ window, verify that the probe being used is the correct one for the monitor's SpO₂ configuration (Nellcor, Nonin) or that the probe is not defective.

Press the SILENCE/RESET pushbutton. The monitor silences the audio alarm tone, but the message remains. Remove the defective probe and replace it with a working probe.

If the SpO₂ Module located inside the CARDELL Monitor should fail, the message “Err” will appear in the %SpO₂ display window.

Press the SILENCE/RESET pushbutton. The monitor silences the audio alarm tone, but the message remains.

Should any of the above problems persist, contact CAS Medical Systems, Inc.

ERROR MESSAGES ON THE MESSAGE WINDOW

The CARDELL Monitor displays a variety of messages on the Message Window to aid the user.

ERROR MESSAGE	POSSIBLE CAUSE	POSSIBLE SOLUTION
"Air Leak"	Air leak in cuff/hose/monitor pneumatic system.	Check that the cuff/hose/monitor connection is secure. Check cuff for leaks. DO NOT use a known leaky cuff.
"Chk Prb"	The monitor is questioning the quality of the signal being received by the SpO ₂ sensor. The sensor is receiving too much ambient light.	Verify that the sensor is being used according to the manufacturer's recommendations. Verify that the sensor emitter and detector are parallel to and directly opposing each other.
"ChksumEr"	An electronic failure has occurred within the monitors' Main Control Board.	Contact CAS Medical Systems to have the monitor serviced.
"Dead Bat"	The battery is fully discharged.	Recharge the battery for at least 4 hours.
"Flow Err"	Stable cuff pressure cannot be maintained by the pneumatic system.	Check the external tube for kinks. Perform a Pneumatic Check as detailed in the Maintenance section of this manual. Replace cuff.
"LooseCuf"	Cuff applied too loosely.	Check cuff for proper fit on patient.
"Low Batt"	The battery is almost discharged.	At least 30 minutes of operation is available from when the message first appears. Recharge the battery as soon as possible.

Table 5: **Error Messages on the Message Window**

ERROR MESSAGES ON THE MESSAGE WINDOW (cont.)

ERROR MESSAGE	POSSIBLE CAUSE	POSSIBLE SOLUTION
"Motion"	There was too much extremity motion for the monitor to accurately complete the NIBP measurement in 150 seconds.	Measurements can be obtained when there is limited extremity movement, but the measurement time may be extended. Measurement time is limited to 150 seconds. Restrain patient extremity motion.
"NBP Cal"	Pressure calibration data corrupted within NIBP module.	Pressure module needs recalibration. Contact CAS Medical Systems to have the monitor serviced.
"NIBP Err"	An electronic failure has occurred within the NIBP module.	Remove the battery and power cord from the monitor. Reconnect the battery and cycle power. Contact CAS Medical Systems to have the monitor serviced.
"No Probe"	The monitor is not detecting the SpO ₂ probe.	The probe was disconnected from either the Interface Cable or from the monitor.
"OverPres"	Cuff pressure exceeded 290 mmHg.	Very rapid squeezing of the cuff can cause this error. Repeat the measurement. If this message repeatedly occurs during normal use, the monitor must be serviced.
"P Search"	The monitor is searching for a Pulse signal.	Normal at power-up as the monitor searches for a pulse. The probe position may have changed. Check the probe site.
"Prb OFF"	The monitor is no longer receiving a patient signal from the SpO ₂ probe.	The probe is no longer in contact with the patient. Check the probe site.
"Pwr Fail"	Power was disconnected from the monitor.	Press the SILENCE/RESET pushbutton to clear the message. OR Re-cycle the monitor's power.

Table 5: Error Messages on the Message Window

ERROR MESSAGES ON THE MESSAGE WINDOW (cont.)

ERROR MESSAGE	POSSIBLE CAUSE	POSSIBLE SOLUTION
"RangeErr"	The systolic reading exceeds the measurement range of 265 mmHg.	Repeat measurement. If the message is displayed again, use another method to measure the patient's blood pressure.
"SetClock"	The monitor's clock needs to be set.	The monitor's time and date values are incorrect. Refer to sections: <i>SETTING THE DATE</i> and <i>SETTING THE TIME</i> for more information. The monitor's internal clock battery needs to be replaced. Contact CAS Medical Systems.
"Sig Sat"	Motion pulses too strong.	Limit patient activity; the arm must be still and/or relaxed. Repeat measurement.
"Sys Err"	An electronic failure has occurred within the monitor.	Contact CAS Medical Systems to have the monitor serviced.
"Time Out"	The monitor was unable to complete a measurement within 150 seconds.	An extremely long measurement can be due to a loose cuff, high blood pressure, or monitor re-pumps. Try measurement again. Try higher initial pressure. If message consistently reappears try using another means to obtain patient's blood pressure.
"Weak Sig"	The monitor did not detect any pulses during a NIBP measurement.	Check the fit of the cuff. Repeat measurement.

Table 5: **Error Messages on the Message Window**

11. MAINTENANCE PROCEDURES

INTRODUCTION

This section discusses the tests used to verify performance following repairs or during routine maintenance. All tests can be performed without removing the CARDELL Monitor's cover.

If the CARDELL Monitor fails to perform as specified in any test, repairs must be made to correct the problem before the monitor is returned to the user.

EQUIPMENT REQUIRED

To test the NIBP

- P9 Calibration Kit
- Mercury Manometer
- NIBP Simulator
- 500 mL Pressure Cylinder (CAS p/n 01-02-0248)

To test the SpO₂

- SpO₂ Finger Sensor Simulator

To perform Electrical Safety

- Electrical Safety Analyzer
- Hypot Tester

Data Sheet

This procedure uses a Data Sheet as the record for verifying monitor performance. Once the procedure is completed, CAS recommends the Data Sheet be kept with the respective monitor's Device History Record should verification of monitor performance be questioned.

The *DATA SHEET* can be found on page 73.

BATTERY CHARGE

Perform the following procedure to fully charge the battery.

- 1) Connect the monitor to an AC power source.
- 2) Verify that the monitor is “OFF” and that the Battery Power Visual Indicator is lit Green.
- 3) Charge the battery for at least four (4) hours.

TURNING THE CARDELL MONITOR “ON”

Perform the following procedure to verify the CARDELL Monitor powers “ON” properly.

- 1) Connect the monitor to an AC power source.
- 2) Verify that the monitor is “OFF” and that the Battery Power Visual Indicator is lit Green.
- 3) Do not connect any cables to the monitor.
- 4) Press the On/Standby pushbutton on the front panel to turn the monitor “ON”.

Upon applying power to the monitor, the CARDELL Monitor displays a one (1) second Configuration Setup Test and conducts a four (4) second electronic Power On Self-Test (POST) to ensure that its internal circuits are functioning properly.

NOTE:

The user should use the Power On Self Test as a verification tool that all front panel visual indicators and the audio are functioning properly.

The one (1) second Configuration Setup Test is a visual indication of the CARDELL Monitor’s current configuration. It consists of the monitor’s Model number (9401 Vet or 9402 Vet).

The four (4) second Power On Self-Test consists of:

- All equipped parameter segments are lit for one (1) second.
- All High Alarm Values are displayed for one (1) second in their corresponding numeric display window and an audible tone is emitted from the monitor’s internal speaker. The Message Window indicates “HI LIMS”.
- All Low Alarm Values are displayed for one (1) second in their corresponding numeric display window and an audible tone is emitted from the monitor’s internal speaker. The Message Window indicates “LO LIMS”.
- The monitor’s current time is displayed for 1 second.

Once the test is completed, the monitor indicates that it is “Ready” for use.

DISPLAYING THE TIME

Perform the following procedure to verify the time is set correctly.

Press and hold the CYCLE TIME pushbutton for two (2) seconds.

The monitor displays the time, in 24 Hr. format in the Message Window for as long as the pushbutton is pressed.

Should the time being displayed not be correct, refer to Section SETTING THE TIME.

ALARM AUDIO

Perform the following procedure to verify the audio range for the Alarm volume.

Press the VOLUME pushbutton on the front panel. Verify a Key Click tone is heard and the Message Window displays "ALARM .

Press the VOLUME UP and VOLUME DOWN pushbuttons and verify the Alarm Volume can be adjusted to one of five volume levels.

Set the volume level as desired.

Press the CANCEL pushbutton when completed.

NOTE:

The Alarm Volume level cannot be set to "OFF".

NOTE:

No Key Click will be heard when the Audio Alarm Volume is set to a MINIMUM setting.

SpO₂ AUDIO

(Model 9402)

Perform the following procedure to verify the audio range for the SpO₂ volume.

Press the VOLUME pushbutton twice. Verify a Key Click tone is heard each time and the Message Window displays “SpO₂ 

Press the VOLUME UP and VOLUME DOWN pushbuttons and verify the SpO₂ “beep” volume can be adjusted to one of five volume levels and “OFF”.

Set the volume level as desired.

Press the CANCEL pushbutton when completed.

CONFIGURATION MODE TESTS

Perform the following procedures to verify the following system operations of the monitor.

NOTE:

The monitor must be in the Configuration Mode in order to perform the following functions.

- All LEDs “ON” Check
- +12 Volt Power Supply Check
- Calibration Check
 - System Pressure
 - Over Pressure
- Pneumatic Pressure Checks

ENTERING THE TEST MODE

To enter the monitor Configuration Menu, press and hold the VOLUME and ALARM LIMITS pushbutton keys while the monitor is being turned “ON”.

Once in the menu, press one of the *PREVIOUS* (CYCLE TIME / ALARM LIMITS) programmed pushbutton keys until the Message Window briefly displays “Test Mode” followed by “0 mmHg”.

NOTE:

While in the Test Mode if no pushbutton is pressed within 15 minutes, the monitor will automatically terminate the Monitor Configuration menu and return to the “Ready” mode.

WARNING:

Do not place the monitor in the TEST MODE when a cuff is attached to a patient.

EXIT THE TEST MODE

When you have completed with the Test Mode, press the CANCEL pushbutton to exit. The Message Window will briefly display "Saving" and return to the "Ready" state.

LED CHECK

Perform the following procedure to verify the functionality of all front panel LED displays and visual indicators.

Enter the Test Mode. The Message Window will briefly display "TEST MODE" followed by "0 mmHg".

Press and hold either the ARROW UP or ARROW DOWN pushbuttons.

The monitor will illuminate all appropriate 7-segment displays, bar graph, bell icon and patient mode indicators for as long as the button is pressed.

+12 VOLT POWER SUPPLY CHECK

Perform the following procedure to verify the proper DC input voltage to the Main Control Board.

NOTE:

The monitor must be connected to the AC Line power source to view this voltage level.

Enter the Test Mode. The Message Window will briefly display "TEST MODE" followed by "0 mmHg".

Press and hold the SILENCE/RESET pushbutton.

The monitor will display the input voltage (VDC) reading in the Message Window. Verify the value to be 12 +/- 0.50 V.

CALIBRATION CHECK

A Calibration Kit, (product #P9) is included with the monitor. The kit contains a T-connector with a male and a female luer fitting (for a Calibration Check) and a male luer plug (to be used for the Pneumatic Check).

Obtain a mercury manometer whose accuracy meets the AAMI/ANSI Standard for Non-Automated Sphygmomanometers, 2002.

SYSTEM PRESSURE

Assemble the Calibration Kit according to the diagram provided in the P9 kit.

- 1) Remove the manometer tubing from the inflation bulb. Connect the open ended tubing of the T-connector to the inflation bulb.
- 2) Connect the female luer fitting to the inflation tube leading to the manometer.
- 3) Connect the male luer fitting to the manometer tubing.
- 4) Enter the Test Mode. The Message Window will briefly display "TEST MODE" followed by "0 mmHg".
- 5) Use the manometer inflation bulb to slowly inflate the system pausing for 30 seconds at the following points and verify calibration according to the following table:

0 mmHg +/- 1 mmHg
50 mmHg +/- 4 mmHg
100 mmHg +/- 4 mmHg
150 mmHg +/- 4 mmHg
200 mmHg +/- 5 mmHg

NOTE:

If the monitor does not display the test pressure for the 30-second period, deflate to zero and verify the proper assembly of the calibration set-up. Re-inflate the system. If the monitor again fails to hold the pressure, it is recommended the monitor be returned to CAS Medical Systems for service.

OVERPRESSURE

Inflate the pressure slowly until 290 mmHg +/- 10 mmHg is reached. The Message Window should stop updating and display the message "OverPres".

Press the CANCEL pushbutton to exit the Overpressure Test. The monitor returns to the Calibration Check function.

If the monitor does not meet the above specifications, it is recommended the monitor be returned to CAS Medical Systems for service.

PNEUMATIC PRESSURE CHECKS

PLUG TUBE

Obtain the male luer plug found in the Calibration Kit (product #P9) supplied with the monitor.

Place this plug into the cuff connector at the end of the monitor inflation hose and twist one-quarter turn. The plug must fit securely into the connector for this test to be performed properly.

Enter the Test Mode. The Message Window will briefly display "TEST MODE" followed by "0 mmHg".

Press the START pushbutton to begin the Pressure Check.

The Message Window will display "Chk Prs", will inflate to approximately 170 mmHg and attempt to hold this pressure. The pressure value will be displayed in the SYSTOLIC display window. This test takes about fifteen (15) seconds.

At the completion of a successful Pressure Check, the Message Window will display "Passed"; the monitor will beep two (2) times and will return to the Calibration Check function after five (5) seconds.

If the monitor fails the Pressure Check, the Message Window will display "Leak", the monitor will beep three (3) times and the return to the Calibration Check function after five (5) seconds.

Due to the volume differences of the hoses offered with the CARDELL Monitor, the monitor may incorrectly fail the Plug Tube check. Should the monitor fail the Plug Tube Pressure Check, obtain a 500 ml Pressure Cylinder and follow the 500 ml Pressure Check.

500 ml PRESSURE CHECK

Obtain a fixed volume 500 ml Pressure Cylinder (CAS p/n 01-02-0248).

Place the end of the monitor's inflation hose securely onto the luer fitting at the top of the pressure cylinder. The hose must fit securely onto the connector for this test to be performed properly.

Enter the Test Mode. The Message Window will briefly display "TEST MODE" followed by "0 mmHg".

Press the START pushbutton to begin the Pressure Check.

The Message Window will display "Chk Prs", will inflate to approximately 160 mmHg and attempt to hold this pressure. The pressure value will be displayed in the SYSTOLIC display window. This test takes about fifteen (15) seconds.

At the completion of a successful Pressure Check, the Message Window will display "Passed", the monitor will beep two (2) times and will return to the Calibration Check function after five (5) seconds.

CARDELL MONITOR SERVICE MANUAL

If the monitor fails the Pressure Check, the Message Window will display "Leak", the monitor will beep three (3) times and return to the Calibration Check function after five (5) seconds.

Should the monitor fail the 500 ml Pressure Check, it is recommended the monitor be returned to CAS Medical Systems for service.

NIBP SIMULATOR CHECK

- 1) Exit the Test Mode and connect the CARDELL Monitor to a NIBP Simulator.
- 2) Set the simulator to a pressure value of 120/80, 40 bpm, 100% gain.
- 3) Press the START pushbutton and allow the monitor to take the NIBP measurement.
- 4) Take a total of four (4) NIBP readings. Disregard the first and average the remaining together.
- 5) Verify the NIBP values, displayed on the monitor's front panel, to be within +/- 5 mmHg and the Pulse Rate to be within +/-2% or +/-2 BPM, whichever is greater.

NOTE:

Results may vary based on the NIBP Simulator being used.

OXIMETRY CALIBRATION CHECK

(Model 9402)

The oximeter is factory calibrated to determine the percentage of arterial oxygen saturation of functional hemoglobin. No user calibration is required.

SpO₂ SIMULATOR CHECK

- 1) Exit the Test Mode and connect the CARDELL Monitor to a SpO₂ Simulator of the appropriate type.
- 2) Set the simulator to a SpO₂ value of 98% and a Pulse Rate of 60 BPM.
- 3) Verify the %SpO₂ reading, displayed on the monitor's front panel, to be within +/- 2% digits and the Pulse Rate to be within +/- 3 BPM.

ELECTRICAL SAFETY CHECKS

WARNING:

Do not touch the monitor when performing these tests.

LEAKAGE

- 1) Disconnect all accessories from the monitor.
- 2) Plug the AC power cord from the CARDELL Monitor into the Electrical Safety Analyzer.
- 3) Turn the CARDELL Monitor "ON".
- 4) Perform a Leakage Check per manufacturers instructions. Verify the monitor's leakage to be *less* than 100 micro-amps.

HYPOT (Monitor)

NOTE:

CAS Medical Systems recommends a Hypot Electrical Safety Checks be performed each time the monitor's case is opened or patient isolation is in question.

WARNING:

Do not touch the monitor when performing this test.

Disconnect all accessories from the monitor.

Plug the AC power cord from the CARDELL Monitor into the Hypot Tester.

WARNING:

Do not turn the monitor "ON" during a hypot test.

Perform a Hypot Test, per manufacturers' instructions for **one (1) minute**, at 2.5 KV.

Verify that there was no arcing observed.

HYPOT (SpO₂)

WARNING:

Do not touch the monitor when performing this test.

Connect the appropriate SpO₂ probe and/or cable to the monitor.

Plug the AC power cord from the CARDELL Monitor into the Hypot Tester.

Connect a lead wire from the Ground terminal of the Hypot tester to the SpO₂ probe.

WARNING:

Do not turn the monitor "ON" during a hypot test.

Perform a Hypot Test, per manufacturer's instructions for **one (1) second**, at 1.8 KV.

Verify that there was no arcing observed.

Disconnect the monitor from the test equipment.

This concludes the testing to the CARDELL Monitor.

This page intentionally left blank.

DATA SHEET

Date: _____

Tested By: _____

**Model 9401 & 9402 Monitor
Data Sheet**

Hospital/Clinic:

Monitor Type: _____

Address: _____

Monitor Serial Number: _____

City: _____

State: _____ Zip: _____

Battery Charge

Verify, the Battery Power Visual Indicator is lit. Pass () Fail ()

Turning the CARDELL Monitor "ON"

Monitor displays Model number for one second. Pass () Fail ()

All equipment parameters are lit for one second. Pass () Fail ()

All High Alarm values are displayed for one second, an audio tone is heard and the message "Hi Lims" is displayed in the Message Window. Pass () Fail ()

All Low Alarm values are displayed for one second, an audio tone is heard and the message "Lo Lims" is displayed in the Message Window. Pass () Fail ()

The monitor's current time is displayed for one second. Pass () Fail ()

Displaying the Time

Verify, the monitor's Time is set correctly. Pass () Fail ()

Alarm Audio

Verify, the Alarm Volume can be adjusted to one of five levels. Pass () Fail ()

SpO₂ Audio

Verify, the SpO₂ Volume can be adjusted to one of five levels. Pass () Fail ()

LED Check

Verify, all front panel LED displays and visual indicators are lit. Pass () Fail ()

+12 Volt Power Supply Check

Verify, the voltage reading to be 12 +/- 0.50. Pass () Fail ()

System Pressure

Deflate system pressure to 0 mmHg. Pass () Fail ()

Inflate system pressure to 50 mmHg. Pass () Fail ()

Inflate system pressure to 100 mmHg. Pass () Fail ()

Inflate system pressure to 150 mmHg. Pass () Fail ()

Inflate system pressure to 200 mmHg. Pass () Fail ()

Over Pressure

Verify, the Message Window displays "Over Pres". Pass () Fail ()

Pneumatic Pressure Tests

Plug Tube Test Pass () Fail ()

500 mL Pressure Check Pass () Fail ()

NIBP Simulator Check

Monitor displays correct NIBP values. Pass () Fail ()

Oximetry Simulator Check

Monitor displays correct SpO₂ values. Pass () Fail ()

Leakage

Verify, the monitor's leakage to be *less* than 100 micro-amps. Pass () Fail ()

Hypot

Monitor, verify, no arcing was observed. Pass () Fail ()

SpO₂, verify, no arcing was observed. Pass () Fail ()

12. SERVICE PROCEDURES

INTRODUCTION

CAUTION:

Removal of the "Warranty Void If Removed" sticker voids any warranty the monitor may have. Refer service only to technicians trained by CAS Medical Systems Inc.

This section discusses the replacement of major assemblies found inside the CARDELL Monitor.

WARNING:

Before attempting to open or disassemble the CARDELL Monitor, disconnect the power cord from the monitor and remove the battery.

CAUTION:

Observe ESD (electrostatic discharge) precautions when working within the unit.

TOOLS REQUIRED

- Small, Phillips head screwdriver
- Medium, Phillips head screwdriver
- Flat blade, screwdriver
- Household scissors
- Torque screwdriver
- Adhesive, Loctite 425
- Adhesive, RTV, GE 162 (Electronic Grade)
- 91% Isopropyl Alcohol

REPLACING THE MONITOR BATTERY

A part number for the battery can be found on the label located on the inside panel of the battery pack. When the battery fails to hold a charge it will need to be replaced.

CAS Medical Systems recommends the battery be changed every two (2) years.

REMOVING THE BATTERY

- 1) Turn the monitor "OFF" and disconnect the power cord.
- 2) Push down on the battery latch to unlock the battery door from the rear panel of the monitor.
- 3) Carefully remove the battery pack from the rear panel of the monitor. Refer to Figure 11.

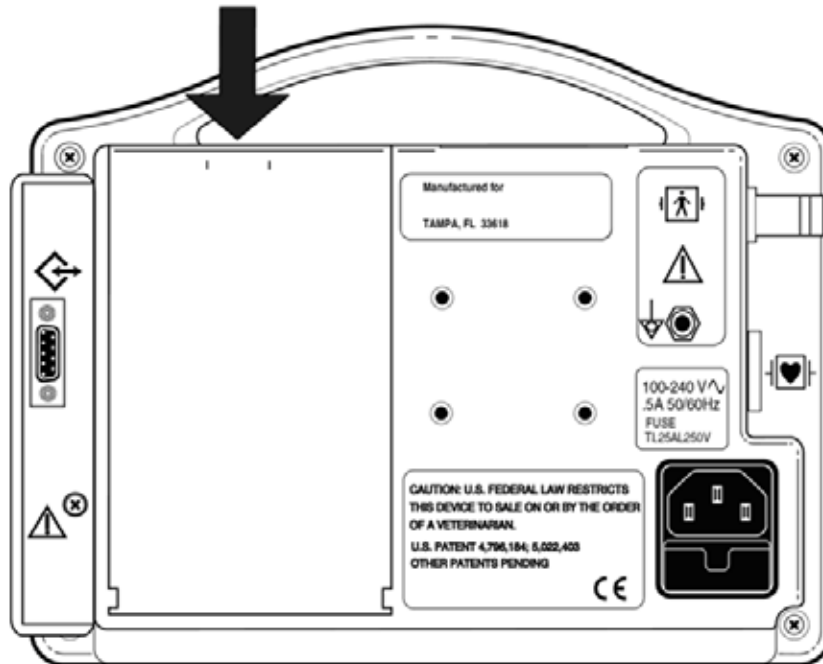

Figure 11: Removing the Battery

INSTALLING THE BATTERY

- 1) Align the Battery Pack guides with the bottom of the monitor.
- 2) Slowly close the battery door to ensure the connector in the monitor and the connector on the battery pack mate together.
- 3) Lock the battery door closed.

NOTE:

When the battery pack is re-installed, the monitor will automatically turn "ON".

WARNING:

Do not disassemble the battery pack or batteries. The batteries contain electrolytes, which can cause injury to eyes, skin and clothing.

NOTE:

This product contains a rechargeable battery that is recyclable. Under various state and local laws, it may be illegal to dispose of this battery into the municipal waste stream. Check with your local authorities for instructions on recycling options in your area.

CHANGING THE FUSES

CARDELL

The CARDELL Monitor uses a dual fuse power input receptacle. The receptacle incorporates fuses in the hot and neutral AC input lines that are user serviceable.

The two (2) fuses for the CARDELL Monitor are each rated at 250V, 500mA or 1.25A, 5 x 20 mm, Slow Blow. Refer to monitor rear panel labeling for actual fuse rating and Section 14, SPARE PARTS for part number information.

CAUTION:

For continued protection against fire hazard, replace only with identically rated fuses.

A fuse may need to be replaced if the monitor is plugged into an electrical outlet but the Battery Power Visual Indicator is not illuminated.

WARNING:

Before changing the fuse, unplug the monitor's power cord.

The fuse holder is incorporated into the power input receptacle and located under the power cord input connector.

To replace fuses:

- 1) Turn the monitor "OFF" and disconnect the power cord.
- 2) Press down on the locking tab, which holds the fuse holder in the power input receptacle.
- 3) While holding down on the tab, pull the fuse holder out.
- 4) Remove the fuses.
- 5) Place new fuses directly into the fuse holder.
- 6) Insert the fuse holder into the power input receptacle. There should be an audible "click" when it is secure.

MAIN MONITOR SERVICE PROCEDURES

PRIOR TO DISASSEMBLY

- 1) Turn the CARDELL Monitor "OFF" by pressing the front panel On/Standby pushbutton.
- 2) Disconnect the monitor from the AC power source.
- 3) Remove the battery from the monitor.

MONITOR DISASSEMBLY

- 1) Complete the steps in *Prior to Disassembly*.
- 2) Set the CARDELL Monitor face down onto a soft surface being careful not to scratch the front display.
- 3) Remove the one (1) screw that secures the RS-232 module to the monitor's rear case. Remove the Module and place it to the side.
- 4) Remove the four (4) corner screws that secure the two case halves together.
- 5) Separate the monitor's front and rear cases, being careful not to stress the internal wire harnesses.
- 6) Disconnect the cable connectors from J1 and J2 on the Main Control Board.
- 7) Place the Rear panel assembly down next to the Front panel assembly.

MONITOR ASSEMBLY

- 1) Connect the Supply harness assembly to J1 on the Main Control Board.
- 2) Connect the Battery harness assembly to J2 on the Main Control Board.
- 3) Place the Rear Case assembly onto the Front Case assembly being careful of all wire harnesses and hoses.
- 4) Secure the two case halves together using the four (4) screws previously removed.
- 5) Re-install the module and secure it to the monitor's rear case using the Loctite adhesive and the one (1) screw previously removed. Apply a small amount of the adhesive to the threads of the screw and torque to 32 in.-oz.
- 6) Perform a complete System Check as described in the section *MAINTENANCE PROCEDURES*.

REPLACING THE POWER SUPPLY MODULE

The Power Supply Module is part of the Rear Case Assembly.

Removal

- 1) Complete the steps in *Prior to Disassembly* and *Monitor Disassembly*.
- 2) Disconnect the two (2) harness assemblies from the Power Supply Module.
- 3) Remove the four (4) screws that secure the module to the rear case.
- 4) Remove the defective Power Supply Module.

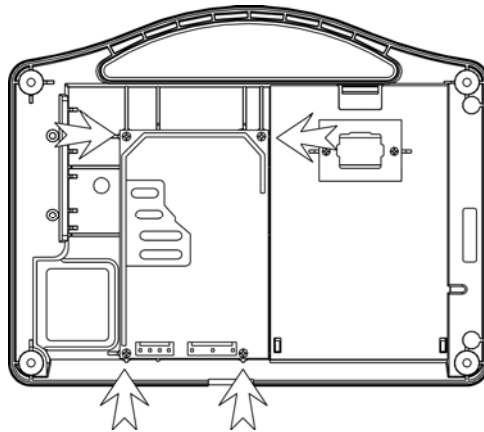

Figure 12: **Replacing the Power Supply Module**

Installation

- 1) Install the Power Supply module into the rear case so that the connectors on the Power Supply Module are at the bottom of the monitor's rear case.
- 2) Secure the Power Supply module using the hardware previously removed.
- 3) Re-connect the wire harness from the AC input receptacle.
- 4) Re-connect the wire harness that will be connected to the J1 connector on the Main Control Board.
- 5) Finish assembling the monitor by following the steps in section *Monitor Assembly*.

REPLACING THE NIBP MODULE

The NIBP Module is part of the Front Case Assembly.

Removal

- 1) Complete the steps in *Prior to Disassembly* and *Monitor Disassembly*.
- 2) Disconnect the NIBP hose from the NIBP connector located on the side panel. Note the location of the hose from the connector to the board.
- 3) Remove the three (3) screws that secure the NIBP Module.
- 4) Separate the NIBP Module from the J4 connector located on the Main Control board.

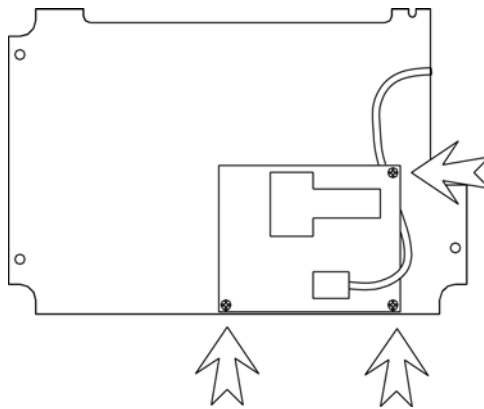

Figure 13: **Replacing the NIBP Module**

Installation

- 1) Align the female connector on the NIBP Module with the J4 connector on the Main Control board. Gently push the NIBP Module onto the connector pins.
- 2) Secure the board to the standoffs using the Loctite adhesive and the hardware previously removed. Apply a small amount of the adhesive to the threads of the screws and torque to 30 in.-oz.
- 3) Re-route the hose under the board and connect it to the NIBP connector on the side panel.
- 4) Finish assembling the monitor by following the steps in section *Monitor Assembly*.

REPLACING THE SpO₂ MODULE

The SpO₂ Module is part of the Front Case Assembly.

Removal

- 1) Complete the steps in *Prior to Disassembly* and *Monitor Disassembly*.
- 2) Disconnect the cable assembly from the SpO₂ board to the Main Control board.
- 3) Disconnect the cable assembly from the side panel input connector to the SpO₂ board.
- 4) Remove the three (3) screws used to secure the SpO₂ board to the Main Control board standoffs. Remove the board.
- 5) Nonin SpO₂ – Remove the Nonin SpO₂ board from the Interface board by gently lifting the PCB from the four (4) nylon standoff support posts while pinching together the prong tips. Separate the SpO₂ board from the J2 connector located on the Interface board.

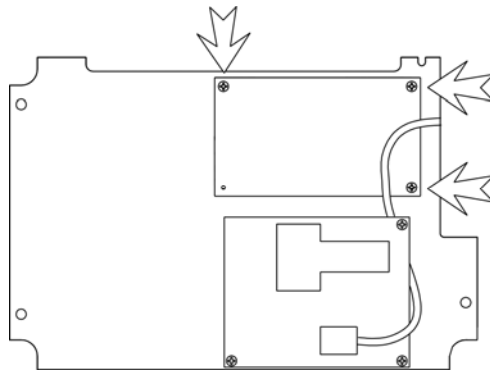

Figure 14: Replacing the SpO₂ Module

Installation

- 1) Nonin SpO₂ – Align the J2 connector with its mating connector on the SpO₂ module and gently push the SpO₂ board down. Secure the board in place by gently pushing down in the four corners.
- 2) Place the SpO₂ module onto the standoffs located on the Main Control board. Secure the board to the standoffs using the Loctite adhesive and the hardware previously removed. Apply a small amount of the adhesive to the threads of the screws and torque to 30 in.-oz.
- 3) Connect the harness assembly from the side panel input connector.
- 4) Connect the harness assembly from the Main Control board.
- 5) Finish assembling the monitor by following the steps in section *Monitor Assembly*.

REPLACING THE MAIN CONTROL BOARD

The Main Control board is part of the Front Case Assembly.

Removal

- 1) Complete the steps in *Prior to Disassembly and Monitor Disassembly*.
- 2) Complete the steps in *Replacing the NIBP module* to remove the NIBP module.
- 3) Complete the steps in *Replacing the SpO₂ Module* to remove the SpO₂ module.
- 4) Remove the four (4) screws that secure the Main Control board to the Front Case.
- 5) Fold the Main Control board out from the Front Case and remove the ribbon cable from the J6 Front Panel Keyswitch connector. Remove the board.
- 6) Remove the Display Shield from over the LED displays on the Control Board.

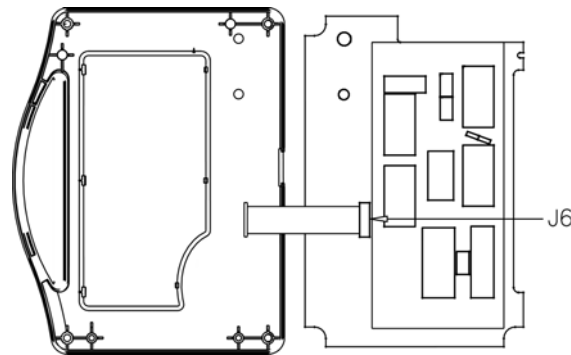

Figure 15: Replacing the Main Control Board

Installation

- 1) Place the Display Shield over the LED displays.
- 2) Adhere the appropriate labels to the LED displays (LARGE CUFF, SMALL CUFF).
- 3) Install the ribbon cable, from the front panel Keyswitch, into the J6 connector.
- 4) Fold the Main Control Board assembly over onto the Front Case.

NOTE:

Ensure the Display Window is free of dust and scratches before assembly.

NOTE:

Be careful not to crimp the ribbon cable between the PC Board and the Front Case.

- 5) Secure the board to the standoffs with the hardware previously removed.
- 6) Re-install the NIBP Board and any remaining option boards previously removed.
- 7) Finish assembling the monitor by following the steps in section *Monitor Assembly*.

REPLACING THE FRONT PANEL KEYSWITCH

The Front Panel Keyswitch is part of the Front Case Assembly.

Removal

- 1) Complete the steps in *Prior to Disassembly* and *Monitor Disassembly*.
- 2) Complete the steps in *Replacing the Main Control Board* to remove the board from the monitor.
- 3) Using the flat blade screwdriver, loosen the keyswitch from the front panel by pushing on the keyswitch from the inside of the front panel in the location where the ribbon cable is located.
- 4) Pry the defective keyswitch loose from the front panel.
- 5) Clean the keyswitch recess surface area of all remaining adhesive with 91% Isopropyl Alcohol.

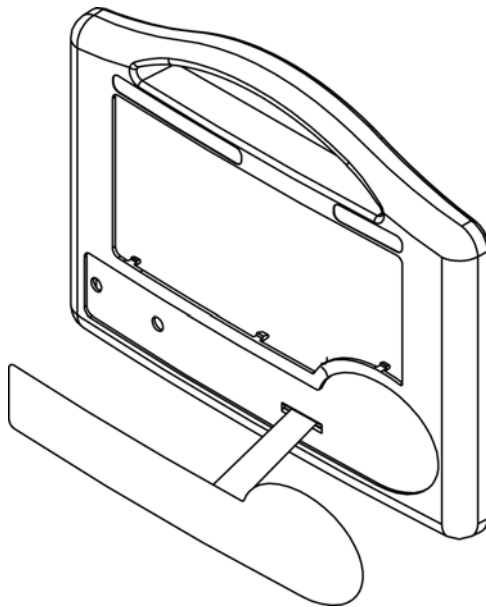

Figure 16: Replacing the Front Panel Membrane Keyswitch

Installation

- 1) Remove the liner from the rear of the keyswitch.
- 2) Feed the ribbon cable through the slot on the Front Panel and carefully position the keyswitch into the recess on the Front Case. Apply even pressure across the face of the keyswitch to secure it in place.

NOTE:

Use extreme caution when handling and positioning the membrane keyswitch. Do not bend, crease or pinch the keyswitch or the tail connector. Do not remove and reapply the keyswitch.

- 3) Plug the ribbon cable connector into the J6 connector on the Main Control Board.
- 4) Using a pair of household scissors cut back the shield tail flush to the front panel.
- 5) Finish assembling the monitor by following the steps in the Installation section of *Replacing The Main Board*.

MODULE SERVICE PROCEDURES

REPLACING THE RS232 INTERFACE BOARD

Removal

- 1) Remove the one (1) screw that secures the Module to the monitor's rear case.
- 2) Remove the three (3) screws that secure the RS232 Interface Board to the Module case.
- 3) Remove the board.

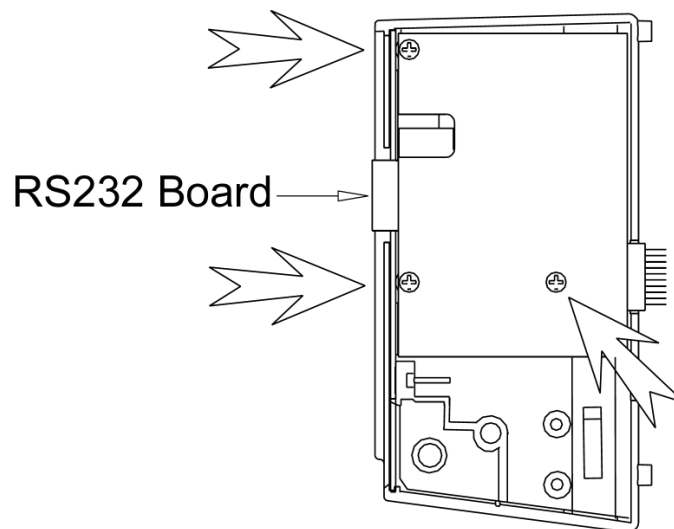

Figure 17: Replacing the RS232 Interface Board

Installation

- 1) Install the RS232 Interface Board into the Module case and secure it with the three (3) screws previously removed.
- 2) Re-install the module and secure it to the monitor's rear case using the Loctite adhesive and the one (1) screw previously removed. Apply a small amount of the adhesive to the threads of the screw and torque to 32 in.-oz.
- 3) Perform a complete System Check as described in the section *MAINTENANCE PROCEDURES*.

This page is intentionally left blank.

13. SCHEMATICS

NIBP BOARD

The NIBP Board used in the CARDELL Monitor is not user serviceable. No schematic diagram is provided.

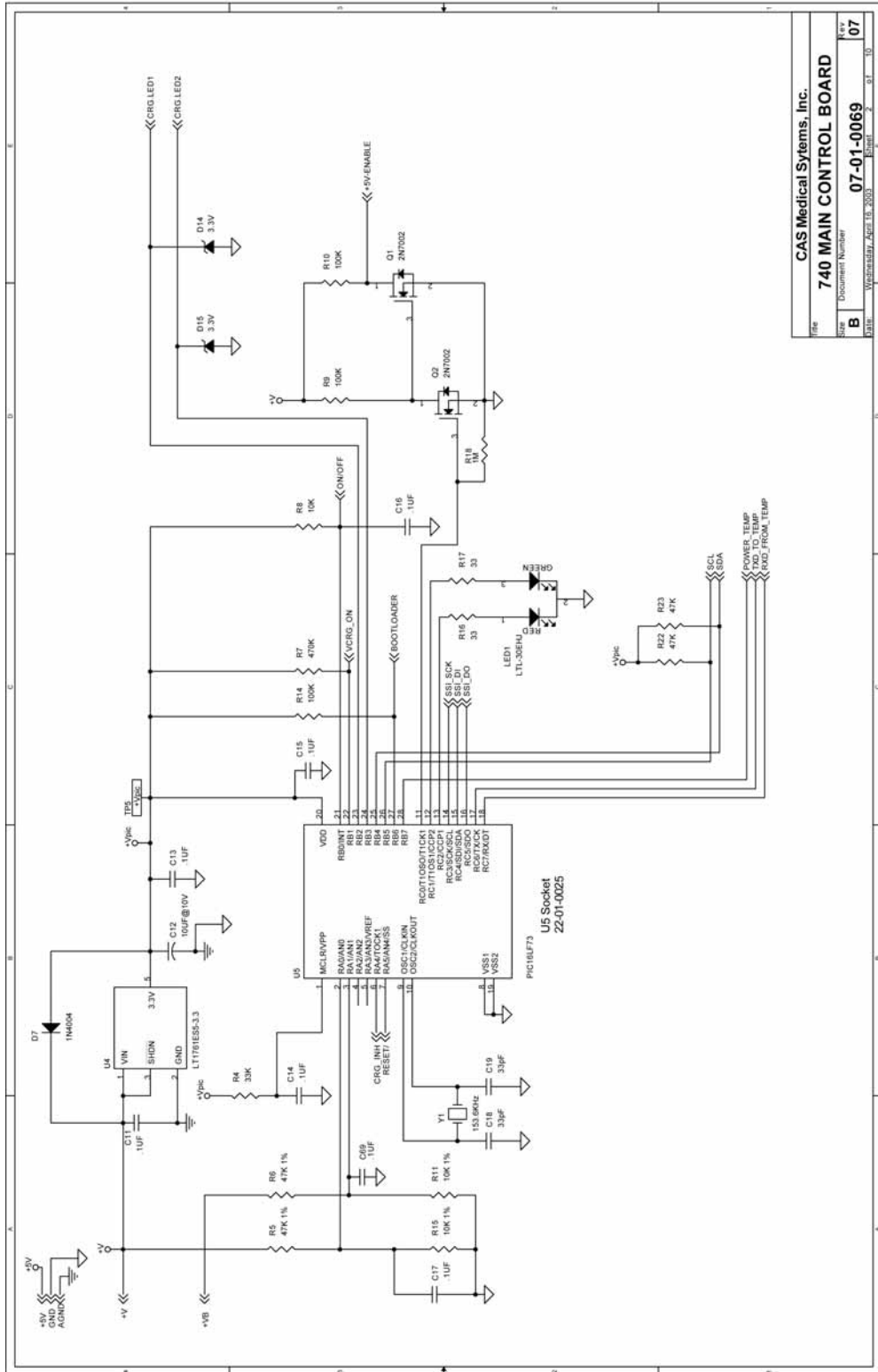

File	CAS Medical Systems, Inc.
Doc	740 MAIN CONTROL BOARD
Sheet	07
Rev	07
Issue	B
Doc Number	07-01-0069
Issue Date	Wednesday, April 18, 2007

CARDELL MONITOR SERVICE MANUAL

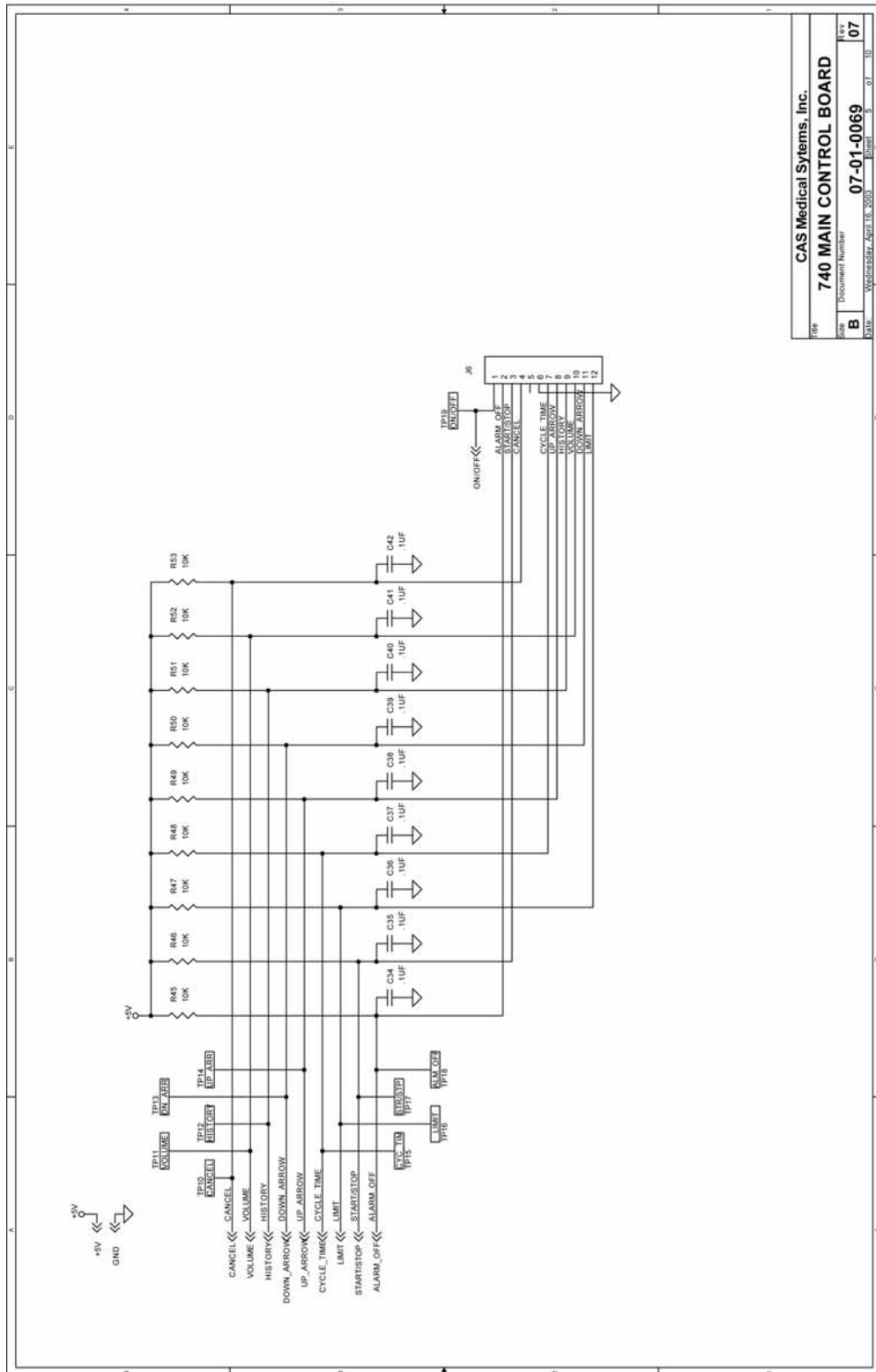

File	CAS Medical Sytems, Inc.
Doc	740 MAIN CONTROL BOARD
Rev	Document Number
B	07-01-0069
Date	Version: April 18, 2003
	Sheet 5 of 10

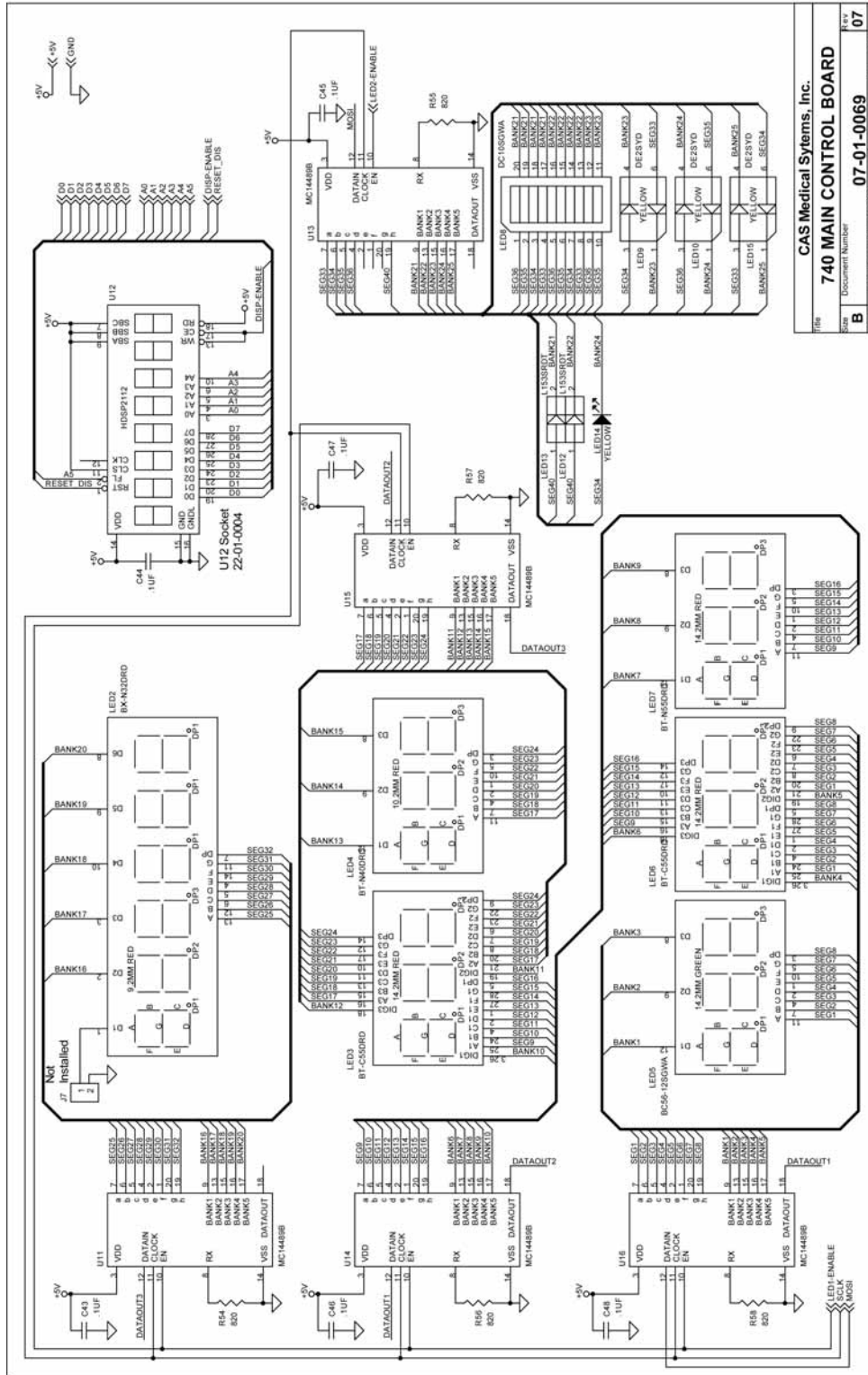

CARDELL MONITOR SERVICE MANUAL

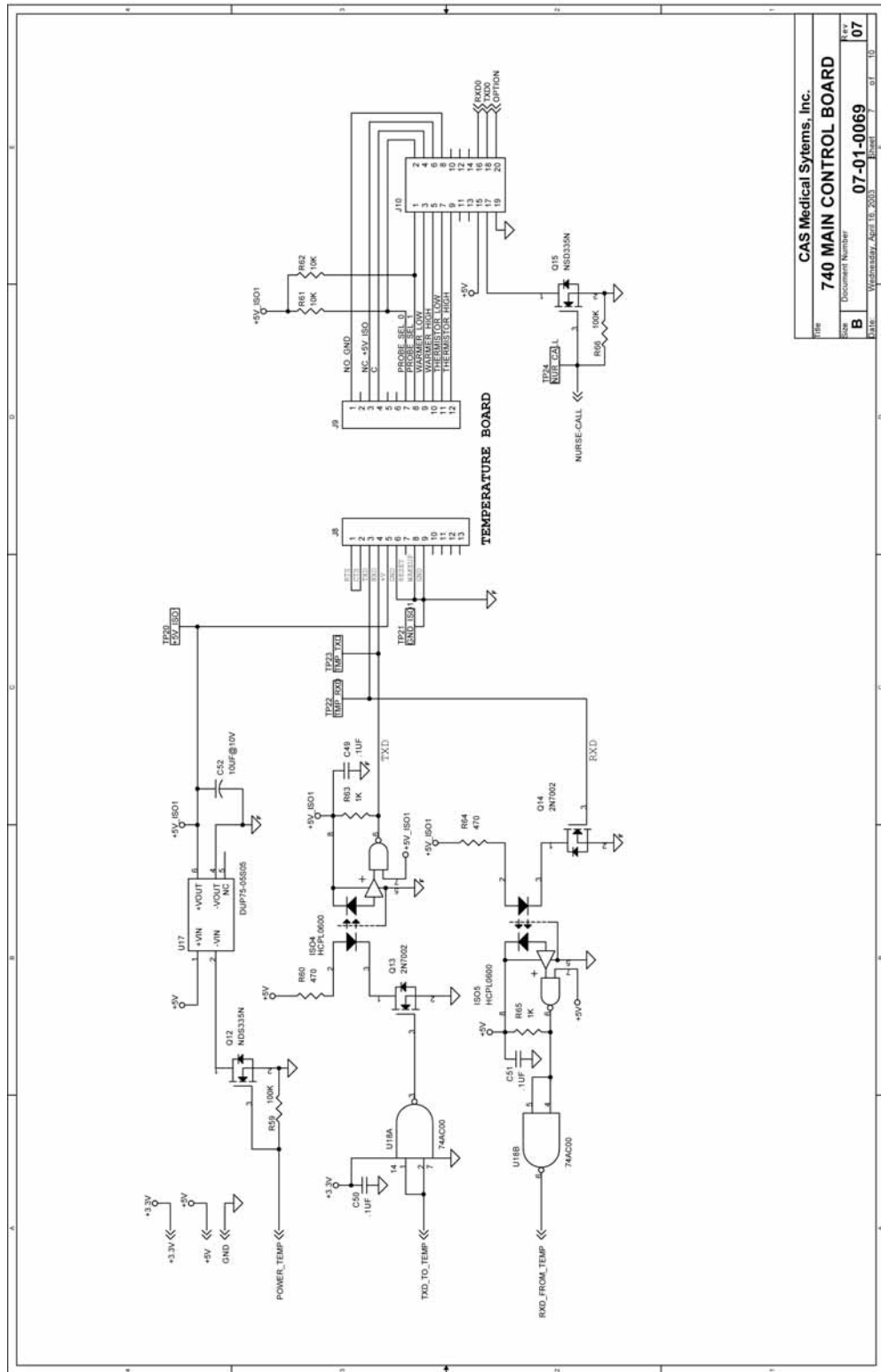

File	CAS Medical Systems, Inc.
Doc	740 MAIN CONTROL BOARD
Doc Number	07-01-0069
Rev	07
Issue	Wednesday, April 18, 2007

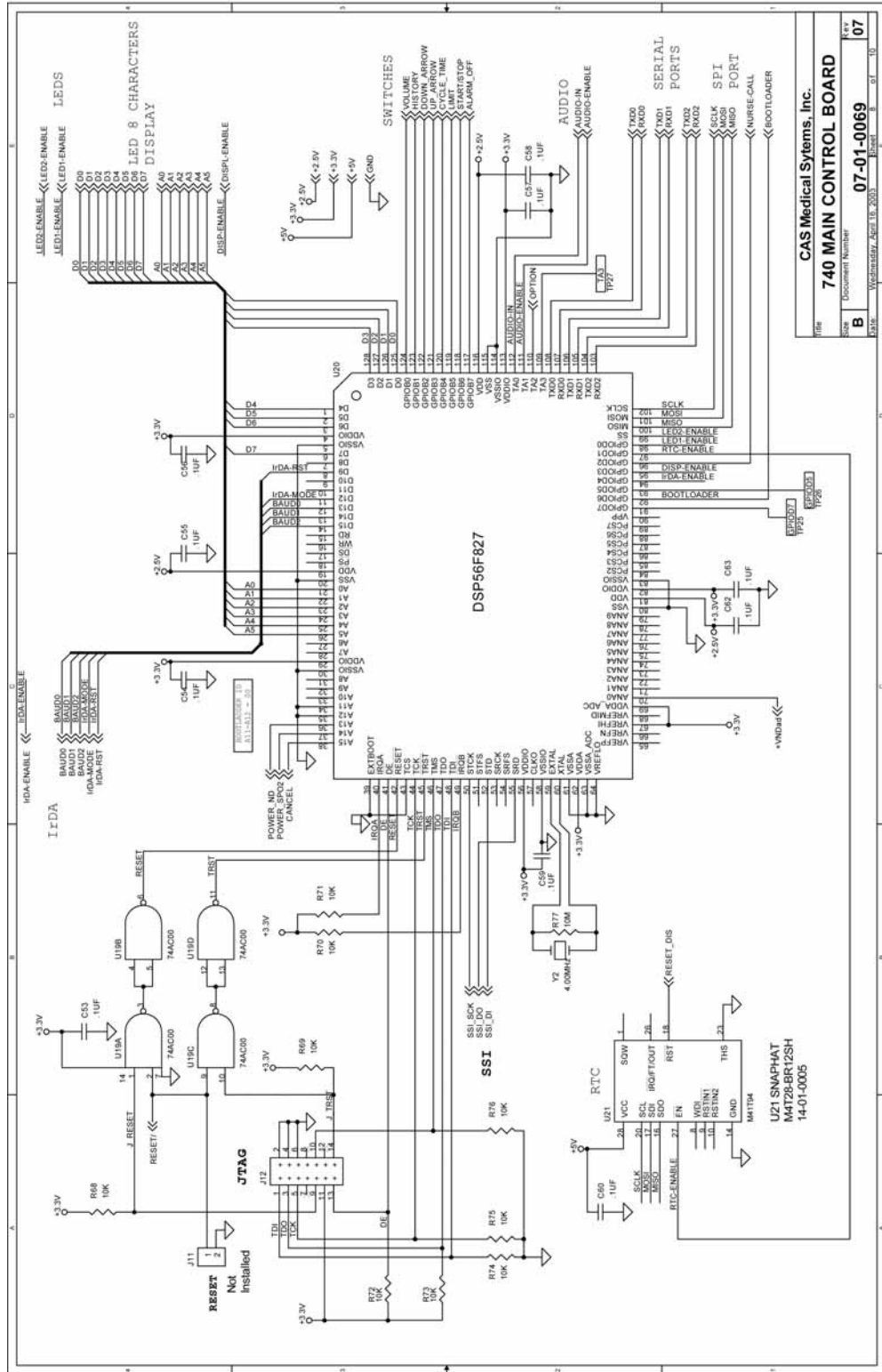

CARDELL MONITOR SERVICE MANUAL

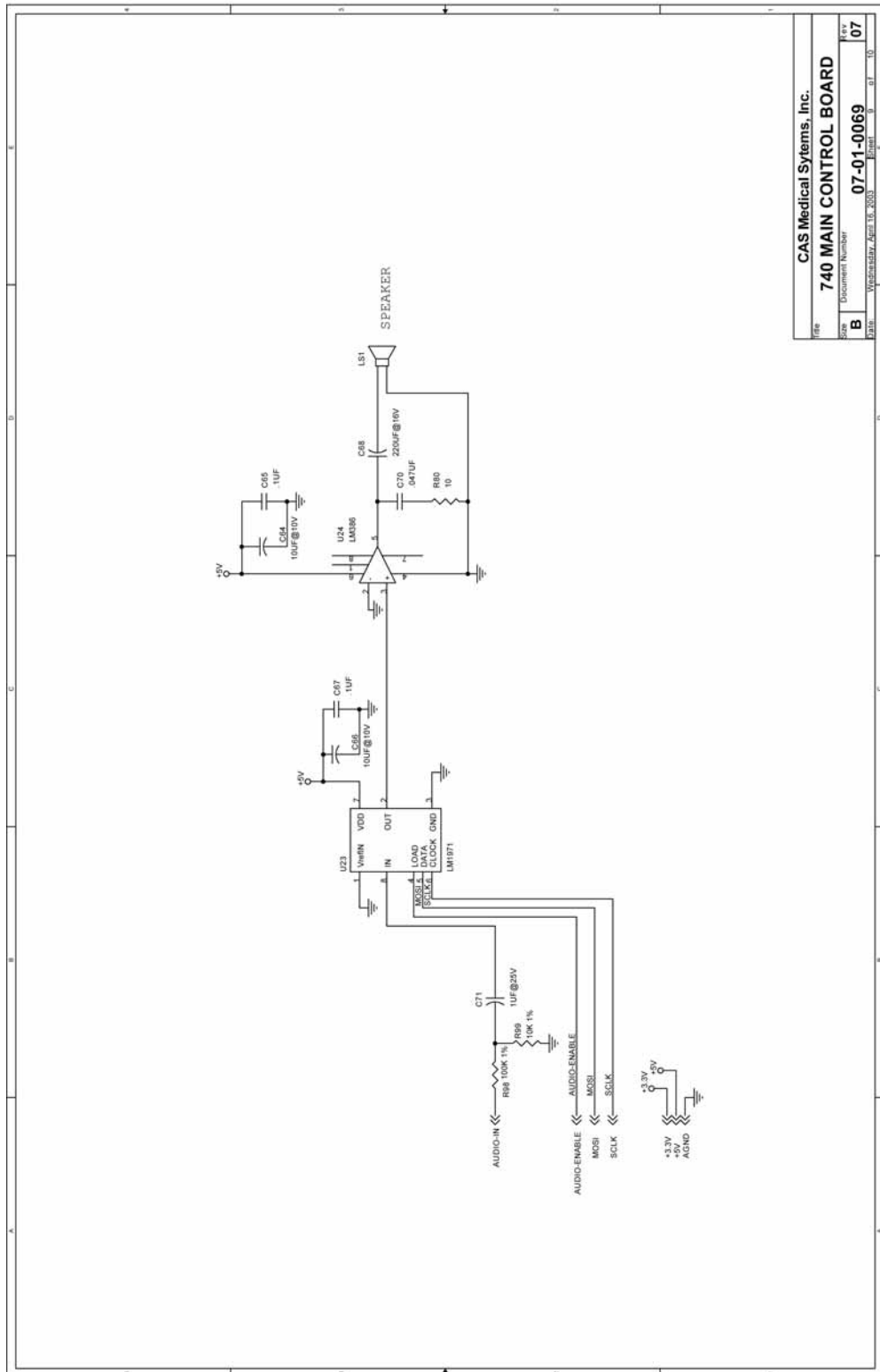

CAS Medical Systems, Inc.	
File	740 MAIN CONTROL BOARD
Doc	Document Number
B	07-01-0069
1376	Wednesday, April 16, 2008 11:01 AM
	07

CARDELL MONITOR SERVICE MANUAL

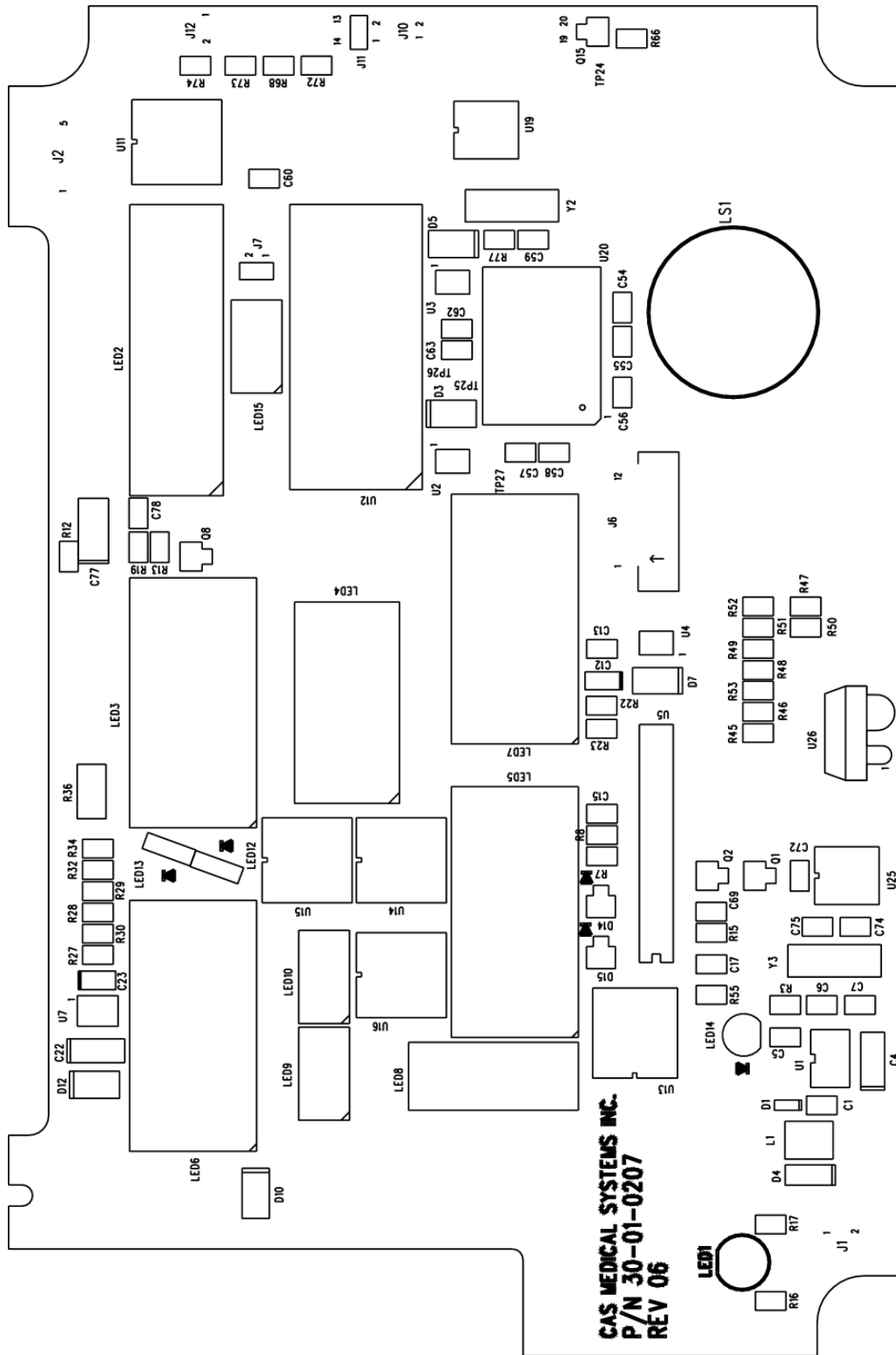

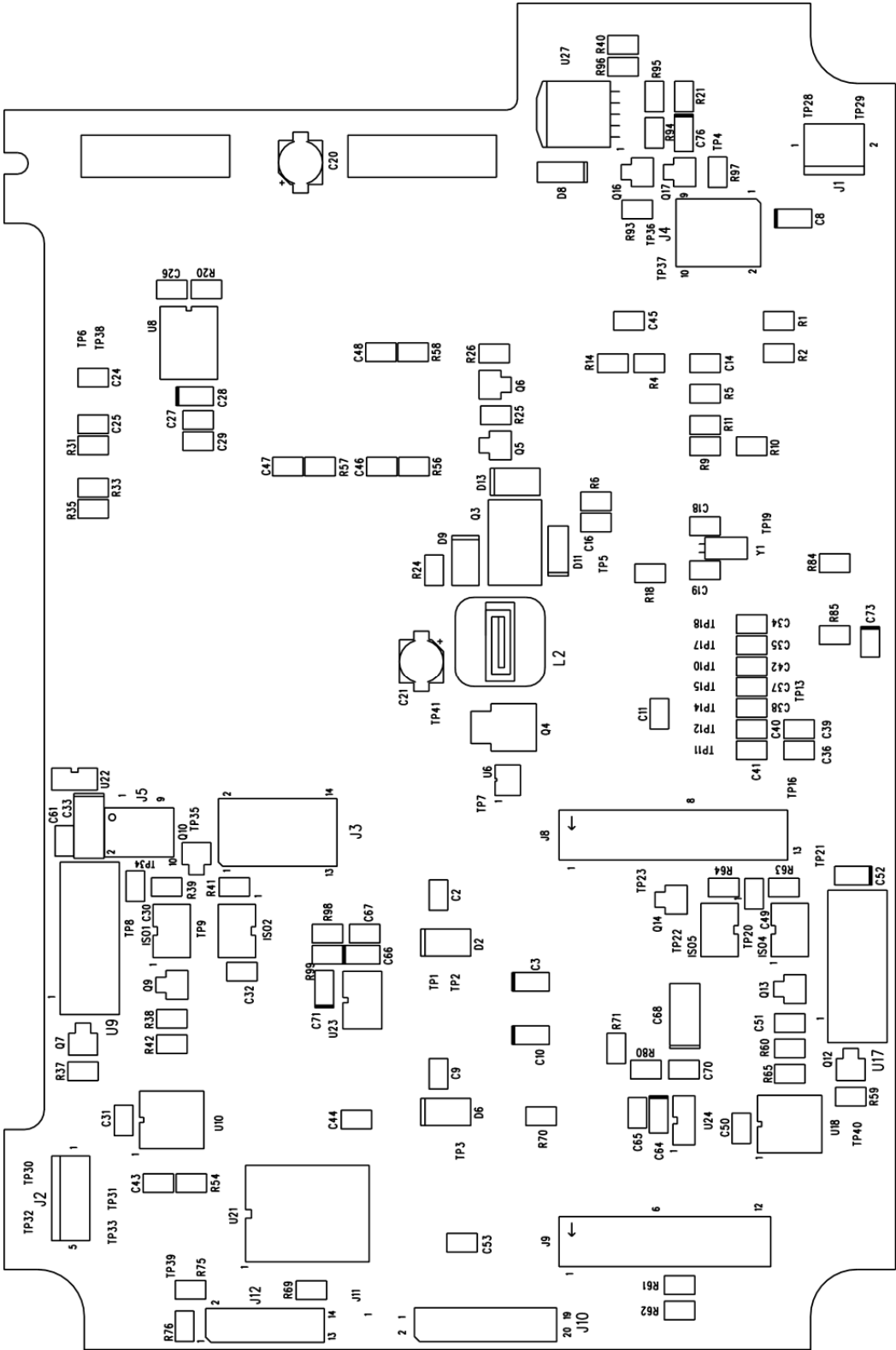

CARDELL MONITOR SERVICE MANUAL

NONIN INTERFACE BOARD

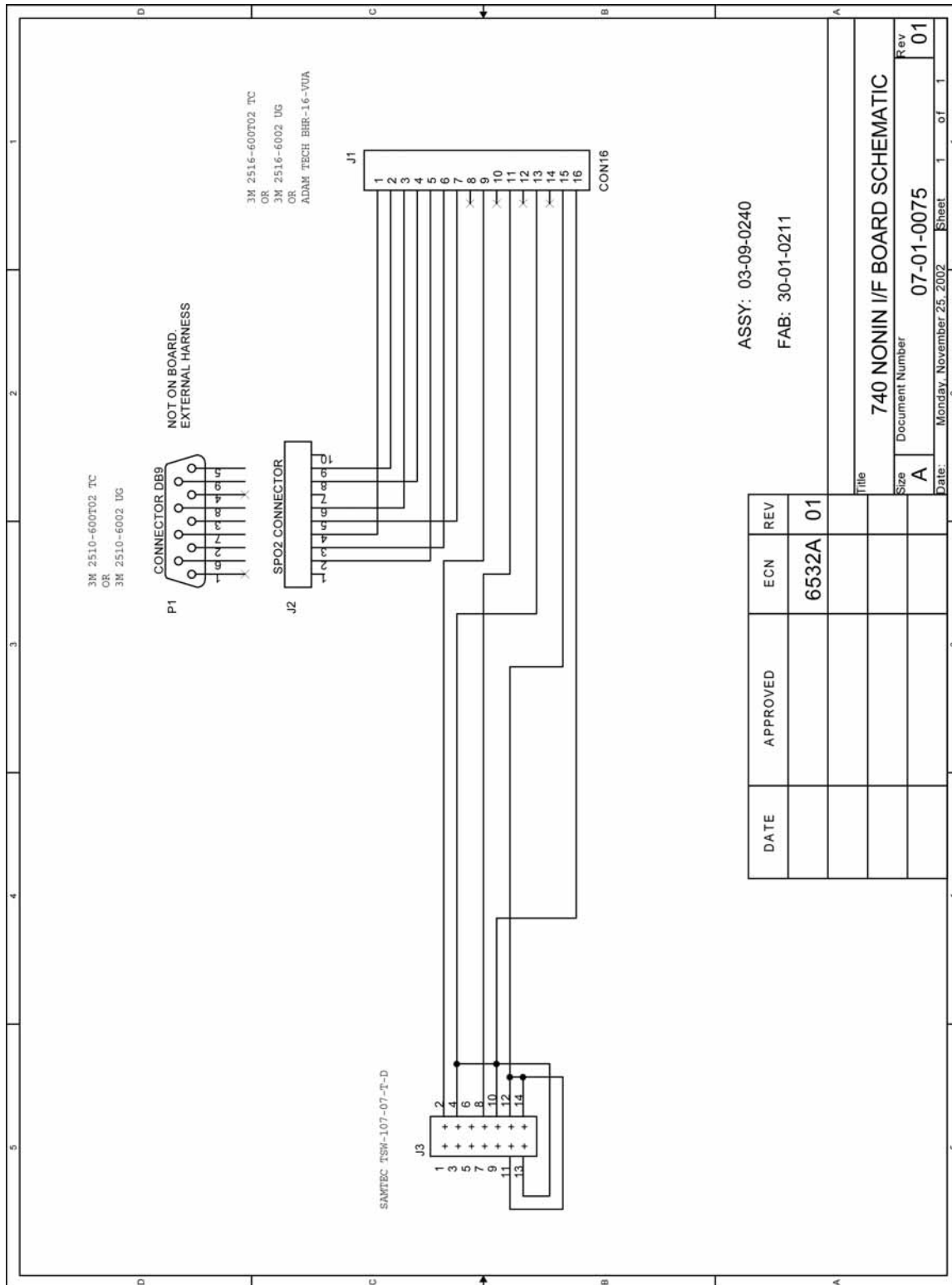

RS 232 INTERFACE BOARD

Page 1 of 2

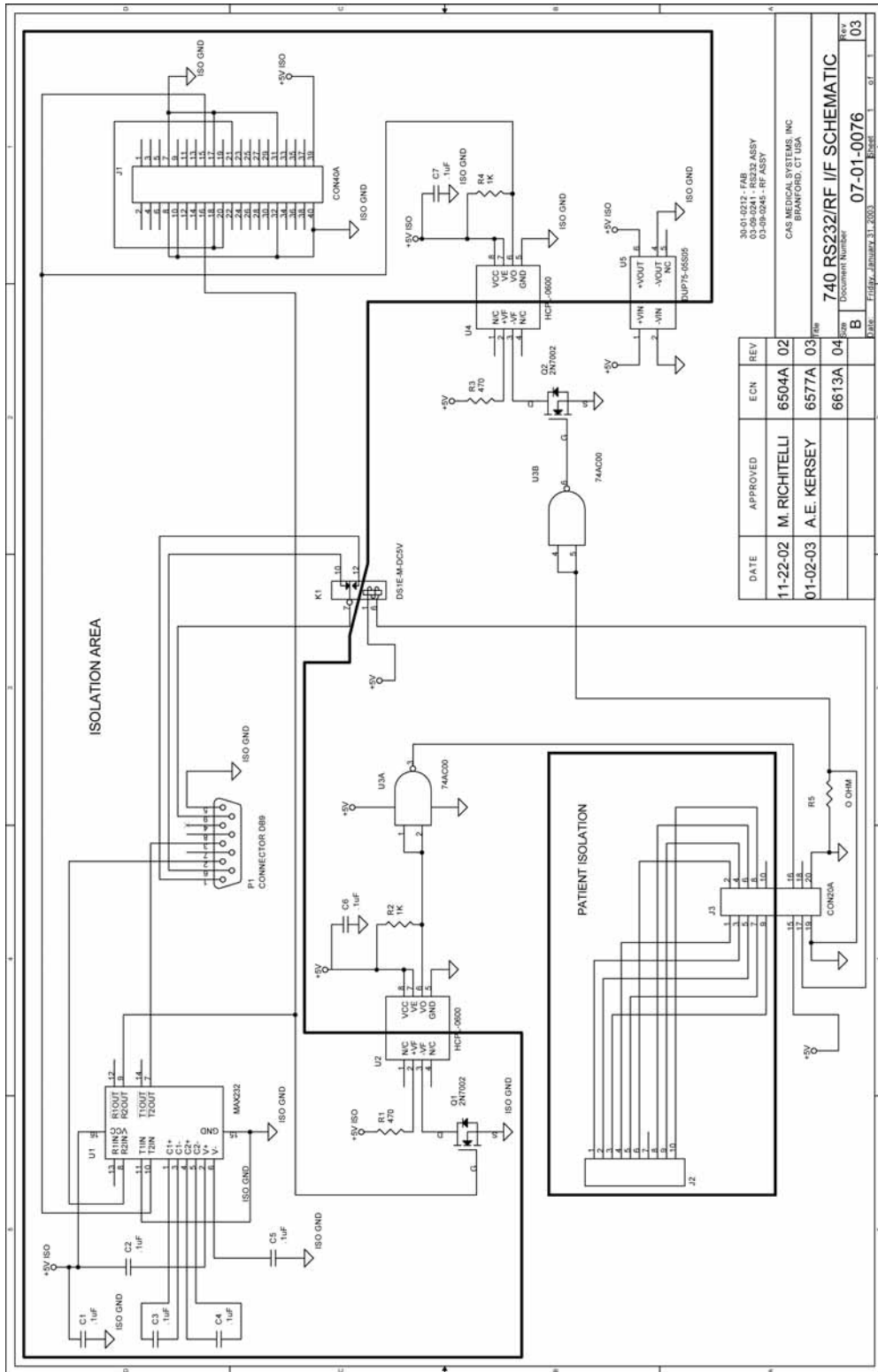

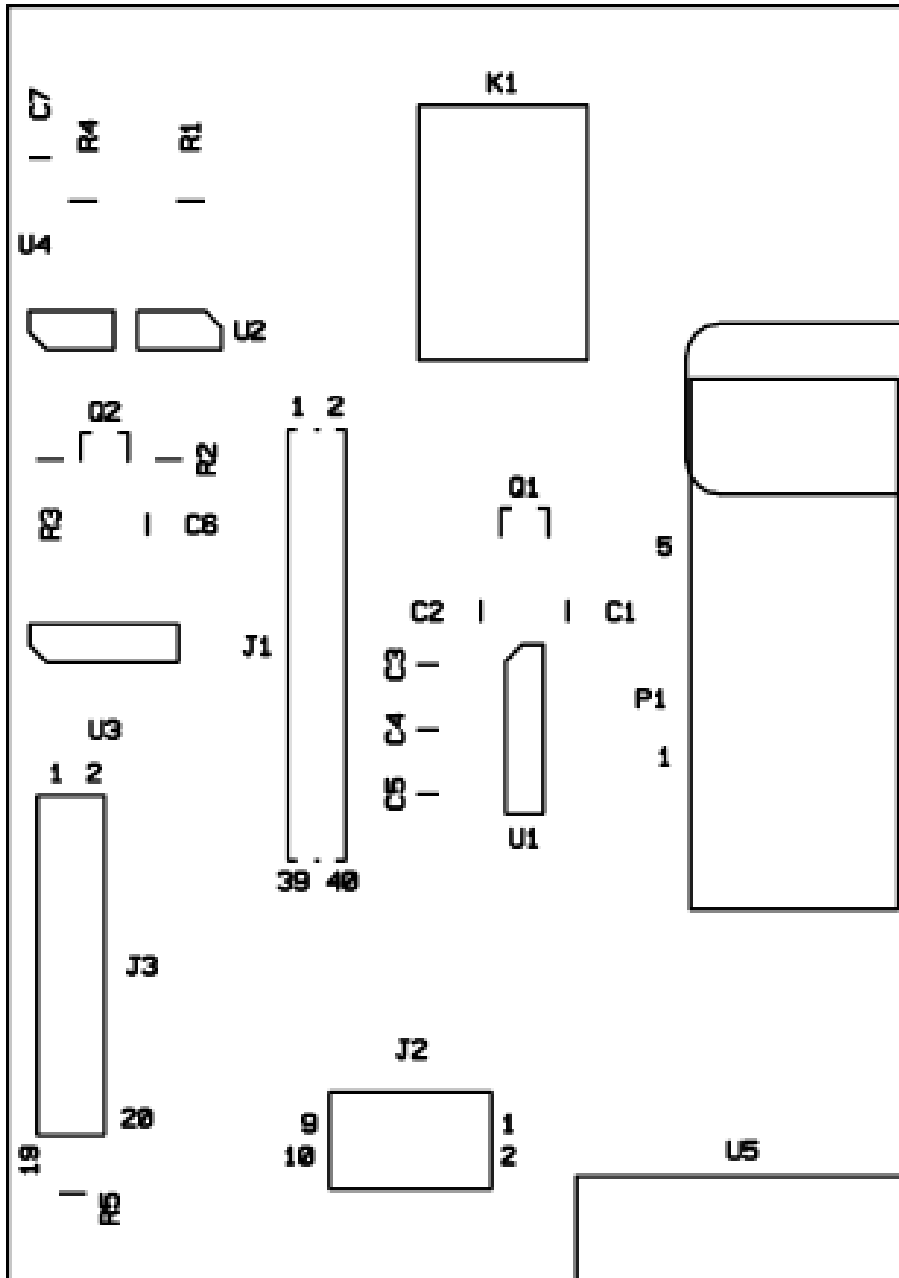

PROPRIETARY BOARDS

Due to the proprietary nature of the Power Supply Board from Condor, the SpO₂ Boards from Nellcor and Nonin, the schematics, board layouts and bill of materials could not be placed into this service manual.

Contact Condor, Nellcor and Nonin directly for this information.

This page is intentionally left blank.

14. SPARE PARTS

PRINTED CIRCUIT BOARDS

<u>Part Number</u>	<u>Description</u>
03-09-0262	Main Control Board (Need to provide complete model number and serial number when ordering)
03-08-0615	ND+ NIBP Module
28-02-0424	Nellcor SpO ₂ Board
28-02-0106	Nonin SpO ₂ Board
11-01-0057	Power Supply Board
03-09-0241	RS232 Interface Board

SWITCHES/CONTROLS/CONNECTORS

<u>Part Number</u>	<u>Description</u>
21-06-0016	Membrane Keypad Panel
27-03-0094	NIBP Input Connector
22-01-0271	Power Entry Module with Line Filter
22-01-0289	Power Entry Module used with Ground Lug (>7/04)

CABLES

<u>Part Number</u>	<u>Description</u>
18-02-0220	Control Board to Battery Harness
18-02-0226	Nellcor to Main Control Board I/F Cable
18-02-0224	Nellcor SpO ₂ Input Cable
18-02-0222	Nonin SpO ₂ Input Cable
18-02-0219	Power Supply to Main Control Board Harness

MISC PARTS

<u>Part Number</u>	<u>Description</u>
23-01-0118	Battery Harness Plate
29-01-0300	Case, Front for 9402
29-01-0294	Case, Front for 9401
29-01-0295	Case, Rear
29-01-0301	Case, RS232 Module
28-02-0422	Foot Pad
09-01-0002	Fuse, 500mA, 5x20mm, SLO-BLO
09-01-0034	Fuse, 1.25A, 5x20mm, SLO-BLO
28-02-0433	Gasket, Side Module
29-01-0299	IR Window
21-01-1317	Label Set
01-02-0248	Pressure Cylinder, 500 mL
29-01-0298	Sensor Connector Panel, Nellcor
29-02-0020	Sensor Connector Panel, Nonin

15. SPECIFICATIONS

NIBP MEASUREMENT

Characteristic	Specification
Technique:	Oscillometric (MAX NIBP® Technology) Microprocessor software eliminates most ambient noise and motion artifact.
Blood Pressure Range	
Systolic:	25 to 265 mmHg
Diastolic:	15 to 220 mmHg
MAP:	20 to 235 mmHg
Pulse Rate Range:	30 to 300 BPM
Accuracy	
Blood Pressure:	+/-5 mmHg with a standard deviation no greater than 8 mmHg (See Standards)
Pulse Rate:	+/-2% or +/-2 BPM, whichever is greater

OXIMETRY (OPTIONS)

Characteristic	Specification
Nellcor®	
Type:	Functional Oxygen Saturation
SpO ₂ % Range:	1 - 100%
SpO ₂ Accuracy:	70 - 100%, +/-2 digits (1 S.D.) Adult 70 - 100%, +/-3 digits (1 S.D.) Neonate
Measurement Wavelengths:	Red 660 Nanometers Infrared 890 Nanometers
Power:	Not exceeding 15 mW
Pulse Rate Range:	20 - 300 BPM
Pulse Rate Accuracy:	+/-3 digits
Numerics:	Updated every one (1) second.

NOTE:

Accuracy is specified for adult human hemoglobin measured at the fingertip. Although animal hemoglobin has similar optical characteristics, other types of hemoglobin may affect the accuracy.

CARDELL MONITOR SERVICE MANUAL

Characteristic	Specification								
Nonin®									
Type:	Functional Oxygen Saturation								
SpO ₂ % Range:	0 - 100%								
SpO ₂ Accuracy:	<table border="0"> <tr> <td style="text-align: center;"><u>Sensor</u></td> <td style="text-align: center;"><u>Accuracy</u></td> </tr> <tr> <td>8000AA</td> <td>70 - 100%, +/-2 digits (1 S.D.)</td> </tr> <tr> <td>8000AP</td> <td></td> </tr> <tr> <td>8000K2</td> <td></td> </tr> </table>	<u>Sensor</u>	<u>Accuracy</u>	8000AA	70 - 100%, +/-2 digits (1 S.D.)	8000AP		8000K2	
<u>Sensor</u>	<u>Accuracy</u>								
8000AA	70 - 100%, +/-2 digits (1 S.D.)								
8000AP									
8000K2									
	<table border="0"> <tr> <td style="text-align: center;"><u>Sensor</u></td> <td style="text-align: center;"><u>Accuracy</u></td> </tr> <tr> <td>8000J</td> <td>70 - 100%, +/-3 digits (1 S.D.)</td> </tr> <tr> <td>8000R</td> <td></td> </tr> </table>	<u>Sensor</u>	<u>Accuracy</u>	8000J	70 - 100%, +/-3 digits (1 S.D.)	8000R			
<u>Sensor</u>	<u>Accuracy</u>								
8000J	70 - 100%, +/-3 digits (1 S.D.)								
8000R									
	<table border="0"> <tr> <td style="text-align: center;"><u>Sensor</u></td> <td style="text-align: center;"><u>Accuracy</u></td> </tr> <tr> <td>8000Q</td> <td>70 - 100%, +/-4 digits (1 S.D.)</td> </tr> </table>	<u>Sensor</u>	<u>Accuracy</u>	8000Q	70 - 100%, +/-4 digits (1 S.D.)				
<u>Sensor</u>	<u>Accuracy</u>								
8000Q	70 - 100%, +/-4 digits (1 S.D.)								
Measurement Wavelengths:	Red 660 nanometers								
	Infrared 910 Nanometers								
Power:	3 mW nominal								
Pulse Rate Range:	18 - 240 BPM								
Pulse Rate Accuracy:	+/-3% or +/-1 digit, whichever is greater								
Numerics:	Updated every one (1) second.								

NOTE:
For further information on sensors and sensor accuracy, contact Nonin.

PATIENT ALARMS

Patient Parameters	9401		9402	
	Low Limit	High Limit	Low Limit	High Limit
SYS:	30 – 260	30 – 260	30 – 260	30 – 260
DIA:	20 – 215	20 – 215	20 – 215	20 – 215
MAP:	25 – 230	25 – 230	25 – 230	25 – 230
Pulse:	35 – 295	35 – 295	35 – 295	35 – 295
% SpO ₂ :			70 – 95	80 – 99
SpO ₂ Pulse:			25 – 295	25 – 295

NOTE:

Each alarm limit may also be selected “OFF” individually or as a whole.
 Low Limits cannot be set above the associated High Limit.
 High Limits cannot be set lower than the associated Low Limit.

CONTROL PANEL

Characteristic	Specification
Display:	LED display of measurement results, instructions, troubleshooting messages and signal strength bar.
Parameters Displayed:	Systolic Pressure, Diastolic Pressure and Mean Arterial Pressure (MAP) Pulse Rate %SpO ₂

SAFETY LIMITS

Characteristic	Specification
Automatic Cuff Deflation:	If cuff pressure exceeds 290 mmHg If measurement time exceeds 150 seconds If safety timer detects microprocessor failure

CARDELL MONITOR SERVICE MANUAL

OPERATING MODES

Characteristic	Specification
Patient:	Veterinary
NIBP:	Manual, STAT or Automatic (at preset intervals)
History:	Review of previous measurements
%SpO ₂ :	Continuous Monitoring
Temperature:	Predictive or Continuous Monitoring

POWER

Characteristic	Specification
Source:	External line or internal battery
AC Power:	100 - 240 VAC, 50/60 Hz, 0.5A; Fuse Rating – T500mAL250V or T1.25AL250V (two provided) Refer to monitor rear panel labeling for actual fuse rating.
Battery:	Nickel Metal Hydride (NiMH) battery pack (user removable) Charge Time: 4 hours Operation on battery: 100 NIBP readings when set in the 5-minute Automatic Mode
Leakage Current:	100 microamp (maximum)

FEATURES

Characteristic	Specification
Self Test:	System self test is performed each time power is turned on.
Auto Zero:	Zero pressure reference is automatically established after every reading.
Inflation:	Initial inflation to 150 mmHg or user selectable. (80, 100, 120, 140, 150, 160, 180, 200). Subsequent inflation to approximately 30 mmHg greater than previous Systolic pressure.
Deflation:	Automatic
Max Measurement Time:	Limited to 150 seconds

OPERATING ENVIRONMENT

Characteristic	Specification
Operating Temperature:	0°C to 50°C (32°F to 122°F)
Humidity:	15 to 95%, non-condensing
Altitude:	10,000 to -1,250 ft (700 – 1050 hPa)

Monitors may not meet performance specifications if stored or used outside temperature and humidity ranges. When moving the monitor from a storage location, wait at least one-hour prior to use to allow the monitor to adjust to room temperature.

STORAGE/TRANSPORT ENVIRONMENT

Characteristic	Specification
Storage / Transport Temperature:	-20°C to 60°C (-4°F to 140°F)
Humidity:	15 to 95%, non-condensing
Altitude:	10,000 to -1,250 ft (700 – 1050 hPa)

PHYSICAL DIMENSIONS & WEIGHT

Characteristic	Specification
Base Unit	
H x W x D:	6.75 in x 8.5 in x 3.0 in (17 cm x 21.5 cm x 7.5 cm)
Weight:	3 lbs approx. (1.4 kg)

SERIAL INTERFACE

Characteristic	Specification
Interface:	Bi-directional serial communication
Speed:	9600 for Printer 115200 for CAS Serial Protocol
Signal Level:	RS232C
Data Length:	8 bits
Start Bit:	1 bit
Stop Bit:	1 bit
Parity:	None
Flow Control:	None

STANDARDS

Accuracy complies with that given in American National Standard for Electronic or Automated Sphygmomanometers, ANSI/AAMI SP10, 2002. Adult blood pressure measurements determined with this device are equivalent to those obtained by an auscultatory blood pressure measurement device and neonatal ones are equivalent to those obtained by an intra-arterial blood pressure device, within the limits prescribed by the American National Standard for Electronic or Automated Sphygmomanometers. The 4th Korotkoff sound was used to determine Diastolic pressure. Study findings are available.

Units comply with the following requirements:

- IEC 60601-1
- IEC 60601-1-2
- IEC 60601-2-30
- IEC 60601-2-49
- EN 865
- ETL Listed - UL 2601, CAN/CSA C22.2 No.601.1

CARDELL® is a registered trademark of Midmark.

Nellcor®, VetSat® and OxiMax® are registered trademarks of Mallinckrodt Inc. SatSeconds™ is a trademark of Mallinckrodt, Inc.

NONIN®, NONIN® Finger Clip Sensor and Flexi-Form Sensors are registered trademarks of Nonin Medical, Inc.

CASMED®, **MAXNIBP**®, Tuff-Cuff®, Safe-Cuff®, SoftCheck®, UltraCheck® and “FOR WHAT’S VITAL” are registered trademarks of CAS Medical Systems, Inc.

All units covered by U.S. patent 4,796,184 and 5,022,403. Other patents pending.

Monitors are  marked.

Midmark Corporation
60 Vista Drive
Versailles, OH 45380-0286
Phone: 937-526-3662
Fax: 937-526-5542
midmark.com



Because we care.