



Artizan® Expressions Streamline-Center™ Installation

Applies to Models:
SC144-200
SC120-200
SC96-200

Special Tools:
None

Language of origin: English

Note:
All wiring, including disconnect, and plumbing must be installed by a licensed electrician or plumbing contractor following applicable local, city, and national codes.

 **Equipment Alert**
Inspect all components for shipping damages. A concealed damage report must be filed with the carrier (by the person receiving the goods) within 15 days of delivery.

Note:
Cabinet hardware, configuration, and options may vary. General cabinet hardware, configuration, and options shown for assembly example purposes only.

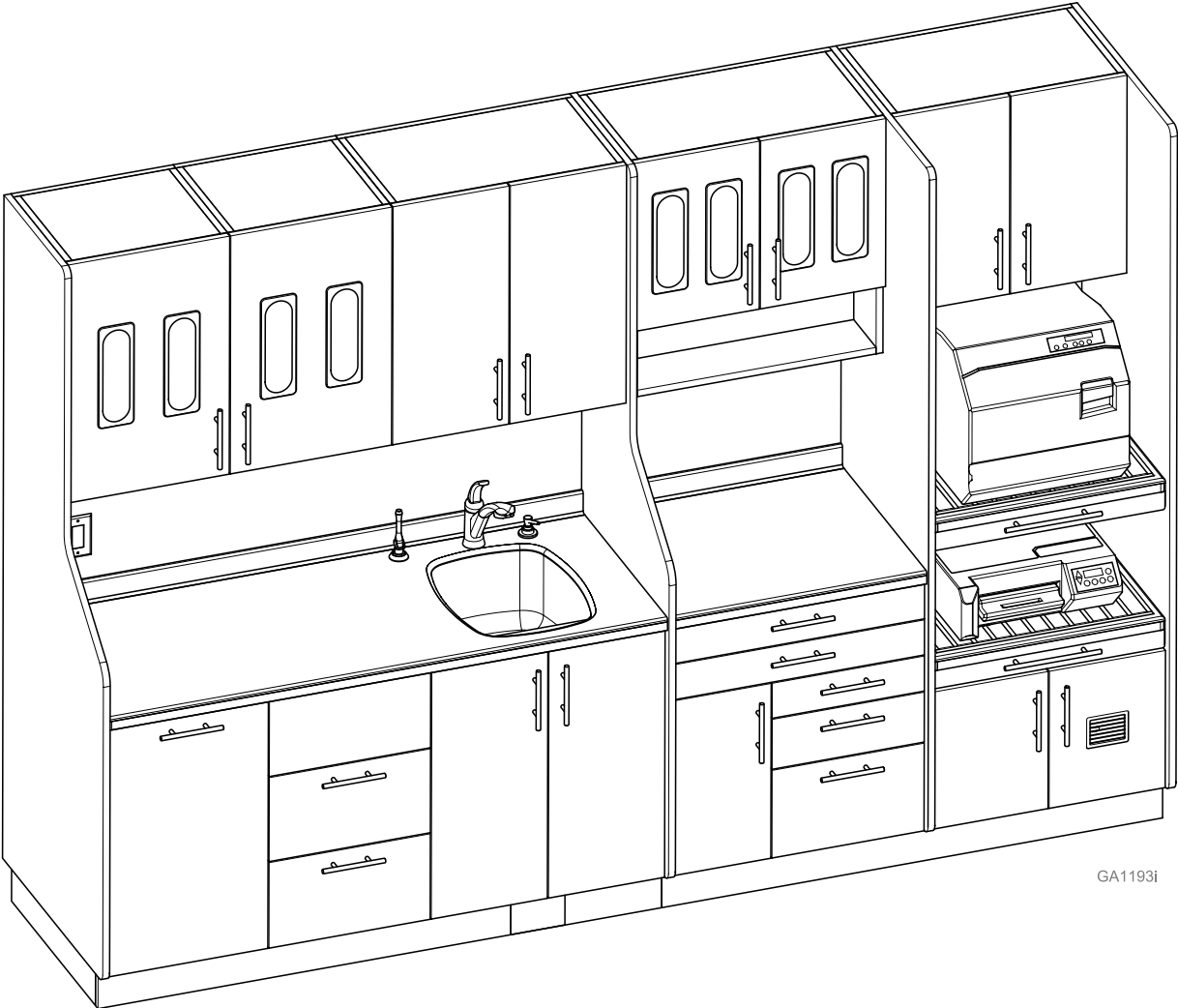

GA1193i

TP201 Rev. A

Important Information and Symbols

These symbols may appear on your equipment and / or in the manuals.



WARNING

Indicates a potentially hazardous situation which could result in serious injury if not avoided.



Caution

Indicates a potentially hazardous situation which may result in minor or moderate injury if not avoided. It may also be used to alert against unsafe practices



Equipment Alert

Indicates a potentially hazardous situation which could result in equipment damage if not avoided.

Note:

Amplifies a procedure, practice or condition.

Contact Information:

Midmark Corporation
115 G.L. Comer Road
Glasgow, Kentucky 42141
Phone: 1-800-643-6275 ext. 88015
Fax: (270)-651-1732

Intended Use

The Artizan® Expressions line of cabinetry is intended for use by the professional dental practitioners as supporting products in their practice providing adequate storage and technology integration for typical operator products and equipment while still retaining an aesthetic appeal. The cabinetry should be designed to address the needs that the dental practitioners have when working in the operator.



Proper Shipping Orientation



Fragile



Keep Dry



Consult User Guide



AC (Alternating Current)



Corrugated Recycle



Pressure Limits



Humidity Limit

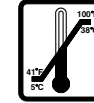

Temperature Limit



Type B Applied Part



Protective Earth Ground



No Stacking

Transportation / Storage / Operating Conditions

Transportation / Storage Temperature Range: ..0°F to 140°F (-18°C to 60°C)
Relative Humidity:.....10% to 90% (Non-Condensing)
Atmospheric Pressure:.....7.2 PSI to 15.3 PSI (50 kPa to 106 kPa)
Operating Temperature Range.....59°F to 95°F (15°C to 35°C)

Disposal of Equipment / Consumable Goods

At the end of this products life, the unit, accessories and other consumable goods may be contaminated from normal use. Consult local codes and ordinances for proper disposal of this equipment and other consumables.

Floor Layout

Note:

Have licensed electrical and plumbing contractors position and install electrical outlet receptacles and related plumbing using the pre-installation layout. Assure floor is of such construction that the cabinet assembly will be adequately supported and anchored if necessary. If necessary contact a licensed contractor to reinforce the flooring.

Note:

A full size, pre-installation floor template is available upon request. Contact your Midmark Customer Experience representative.

**FREESTANDING STERILE
SINK BASE**

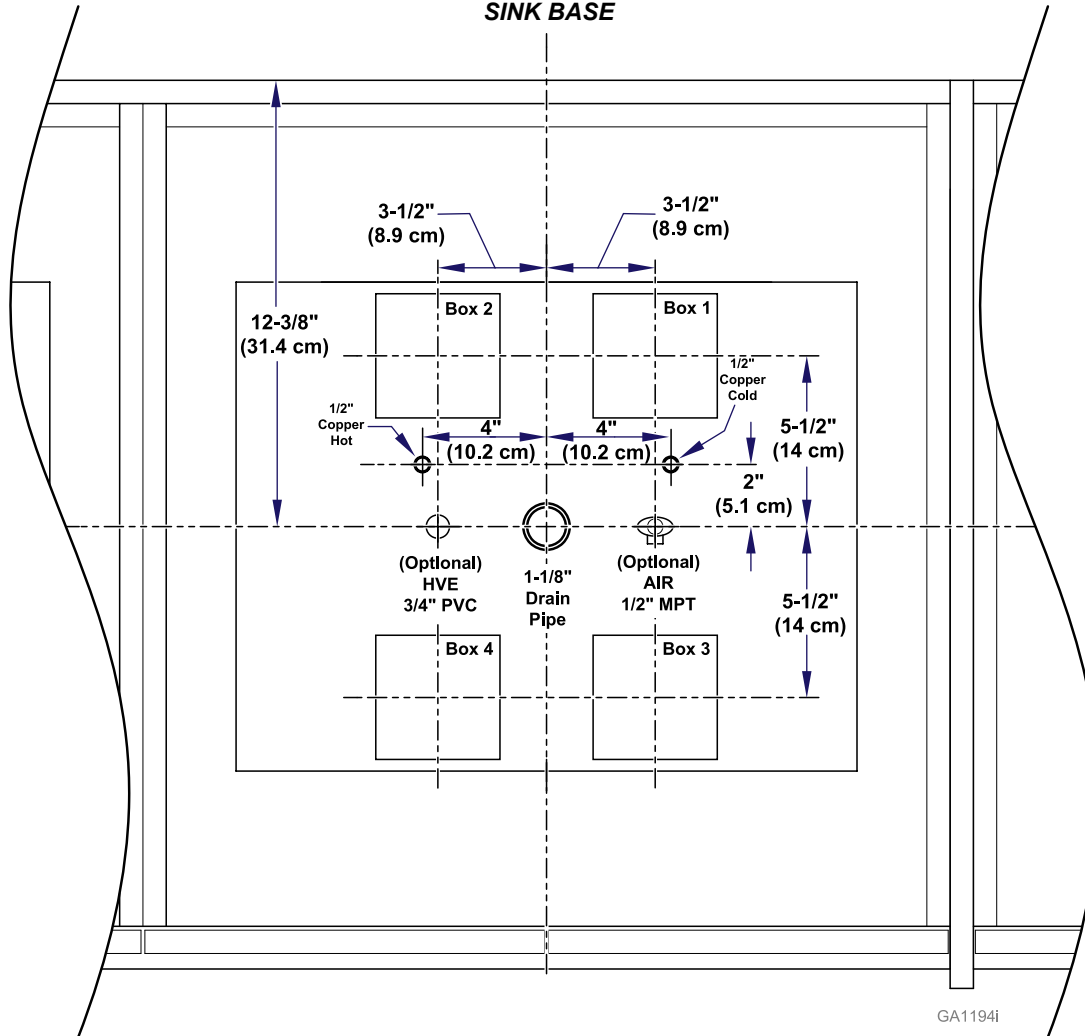

Note:

Vertical dimensions specified from the floor are to the **finished floor**.

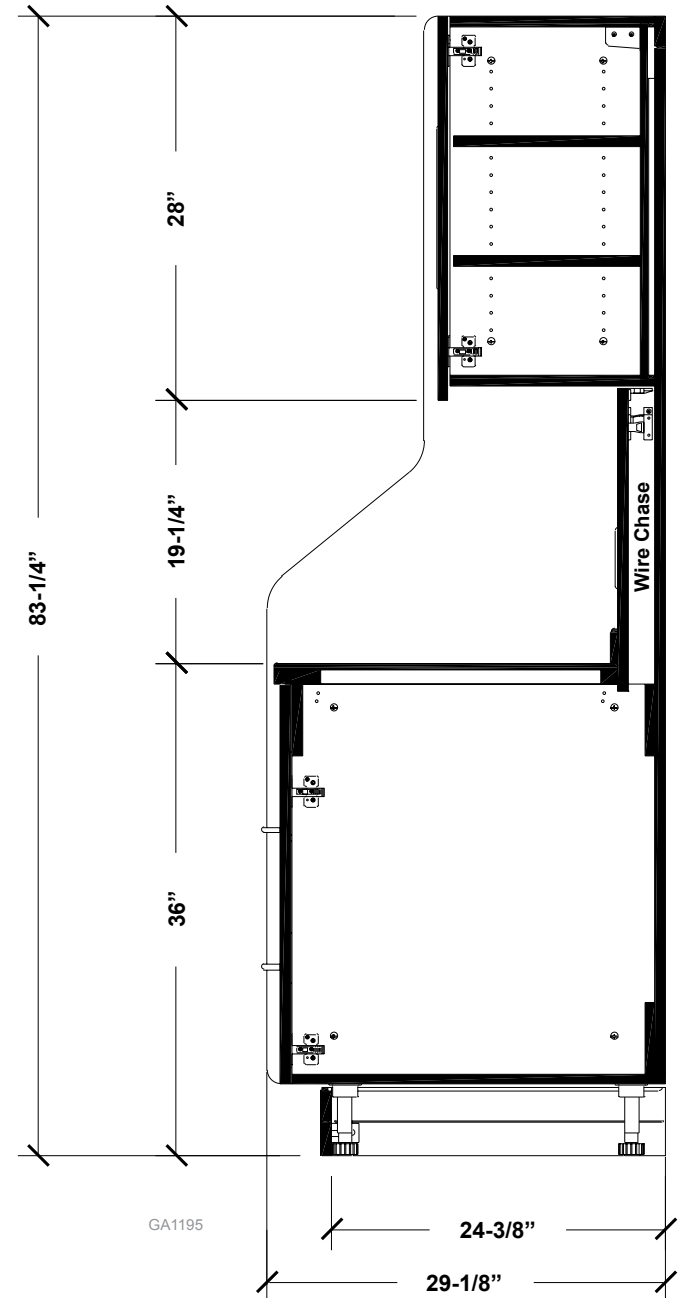

Tower Installation (Sterilization Tower)

Install Sterilization Tower...

- Cut straps and remove lower tower cabinet from packaging.
- Remove cabinet drawers. (See [Drawer Removal, Installation, and Adjustment](#) in this manual)
- Remove cabinet doors and shelves. (See [Door Removal, Installation, and Adjustment](#) in this manual)
- Tip base cabinet on its back and install leg levelers. Adjust leg levelers to 5-1/4" and set base cabinet upright when finished.
- Align the holes of the hang rail with the dado and screw hang rail onto dress panel with the provided 5/8" screws.
- Attach cabinet dress panel using (6) 1/4-20 x 1-1/4" LG machine screws and position the cabinet.

Sterilizer Shelf Glide Removal & Installation...

Removal

- Pull the drawer fully open so levers are visible.
- Push down on the right lever and up on the left lever.
- Hold the levers in place and pull the drawer out further to remove.

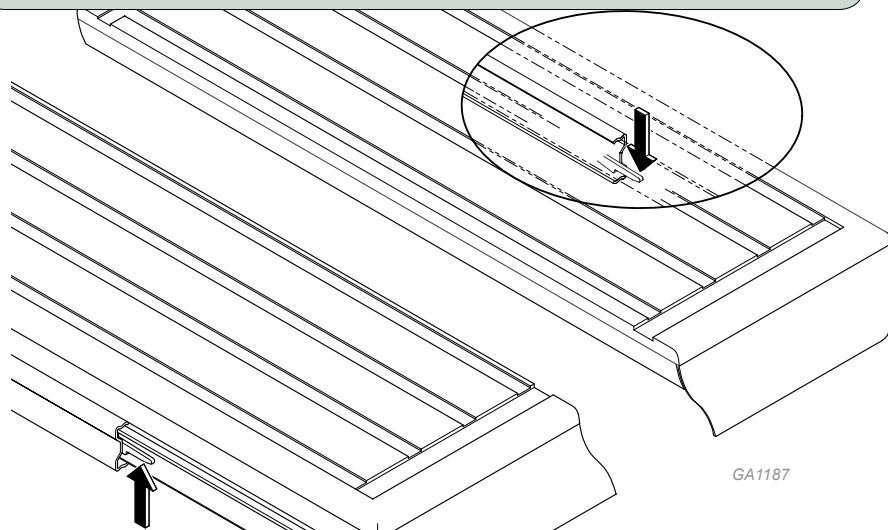

Installation

- Carefully reinsert the drawer member slide into the cabinet member slide.
- Completely close the drawer.
- Open and close the drawer to ensure the slide is fully engaged into the ball bearing track.

Equipment Alert: Maximum Shelf Load is 175lbs.

- Level the lower cabinet by adjusting the leg levelers. See [Adjustable Camar Leg Leveler \(Cabinet Height Adjustment\)](#) in this manual.
- Attach left and right finished walls to the base cabinet using (8) 1/4-20 X 1-1/4" LG machine screws.
- Extend upper hang blocks and hang upper. Retract the hangers to tighten it to the dress panel and adjust upper flush with the top of the dress panels. See [Hang Block Adjustments](#) in this manual.
- Connect the upper cabinet to the finished walls with (8) 1/4-20 X 1-1/4" LG machine screws.
- Install finished back panel. Place the bottom of the panel in notches found in the top rear of the base cabinet, then press the panel into the panel connector until it snaps into place.
- Attach glide cabinet members to the finished walls using (6) M6 x 14mm LG Euro screws with shoulder and install sterilizer shelves. See [Sterilizer Shelf Glide Removal & Installation](#) In this manual. Cabinet members are shipped with the sterilizer shelf.

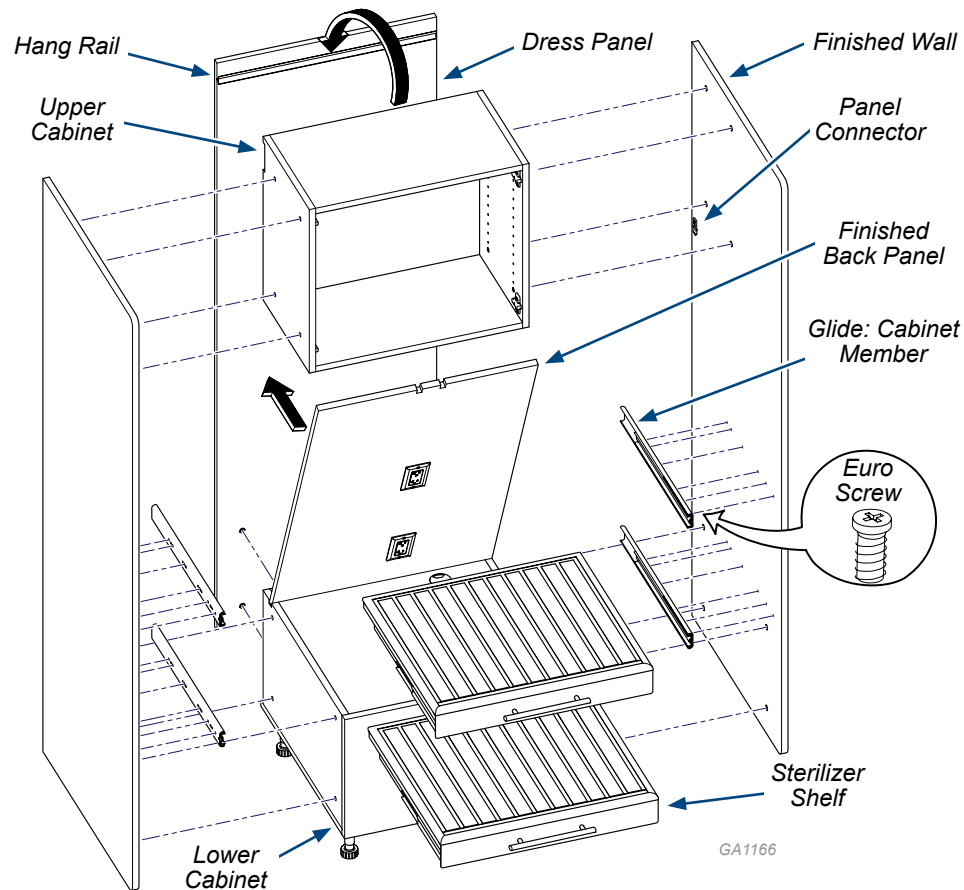

Tower Installation (Clean Storage Pantry)

Install Clean Storage Pantry

- A) Cut straps and remove box from the clean storage pantry.
- B) Install the leg levelers and adjust to 5-1/4" See Adjustable Camar Leg Leveler (Cabinet Height Adjustment)
- C) Before standing the tower upright, place a piece of packaging under the pivot point to take the weight off the legs. Stand the cabinet upright and remove the packaging before moving into place.
- D) Level the cabinet by adjusting the leg levelers. See Adjustable Camar Leg Leveler (Cabinet Height Adjustment)
- E) Make cabinet connections with 1/4-20 X 1-1/4" LG machine screws or connection bolts if adjacent upper and lower connections are required.
- F) Open the door and hang the wire baskets on the frame.

Note: See Electrical Diagrams for electrical connections.



Equipment Alert

Use packaging material as a support while standing the cabinet upright to prevent damage to leg levelers and leg cups.

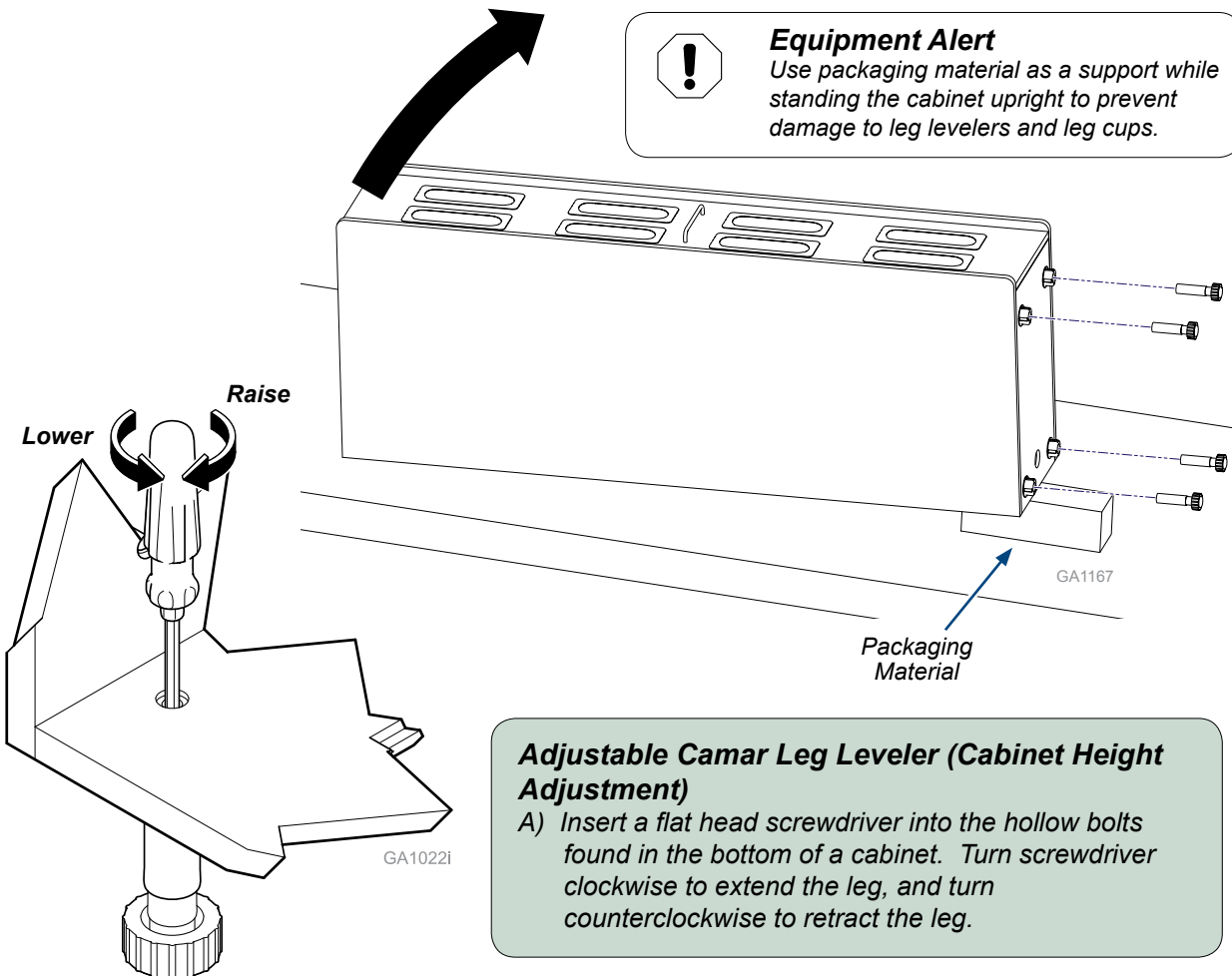

Adjustable Camar Leg Leveler (Cabinet Height Adjustment)

- A) Insert a flat head screwdriver into the hollow bolts found in the bottom of a cabinet. Turn screwdriver clockwise to extend the leg, and turn counterclockwise to retract the leg.

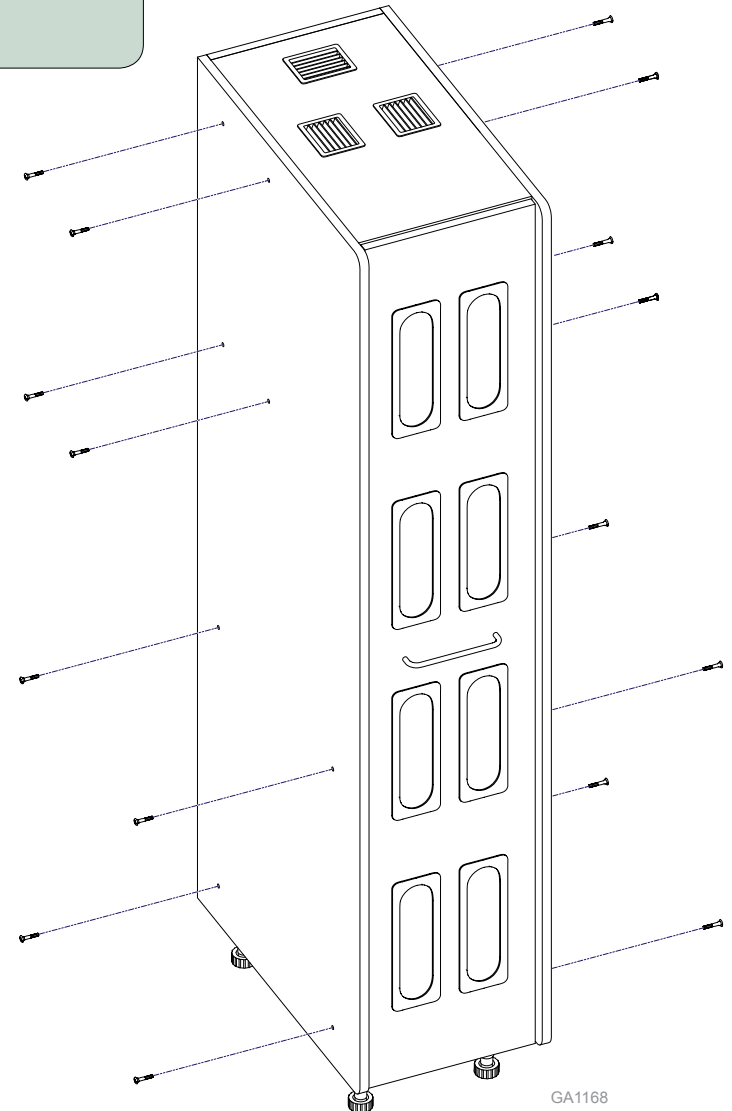

Tower Installation (Tray Storage Tower)

Install Tray Storage Tower

- A) Cut straps and remove lower tower cabinet from packaging.
- B) Remove the shelves and door from the lower cabinet.
See [Door Removal Installation and Adjustment](#) in this manual.
- C) Set lower tower on its back and install leg levelers. Adjust Legs to 5-1/4" and stand cabinet upright.
- D) Attach cabinet dress panel using (4) 1/4-20 X 1-1/4" LG machine screws.
- E) Position and level the lower tower by adjusting the leg levelers. See [Adjustable Camar Leg Leveler \(Cabinet Height Adjustment\)](#) in this manual.
- F) Un-package the upper tower and remove the shelves and door from the cabinet.
See [Door Removal Installation and Adjustment](#) in this manual.
- G) Place the upper tower on the lower tower and use (8) 1/4-20 X 1-1/4" LG machine screws to attach the top cabinet to the lower cabinet and dress panel.
- H) Attach left and right finished walls with (12) 1/4-20 X 1-1/4" LG machine screws or connection bolts if adjacent upper and lower connections are required.

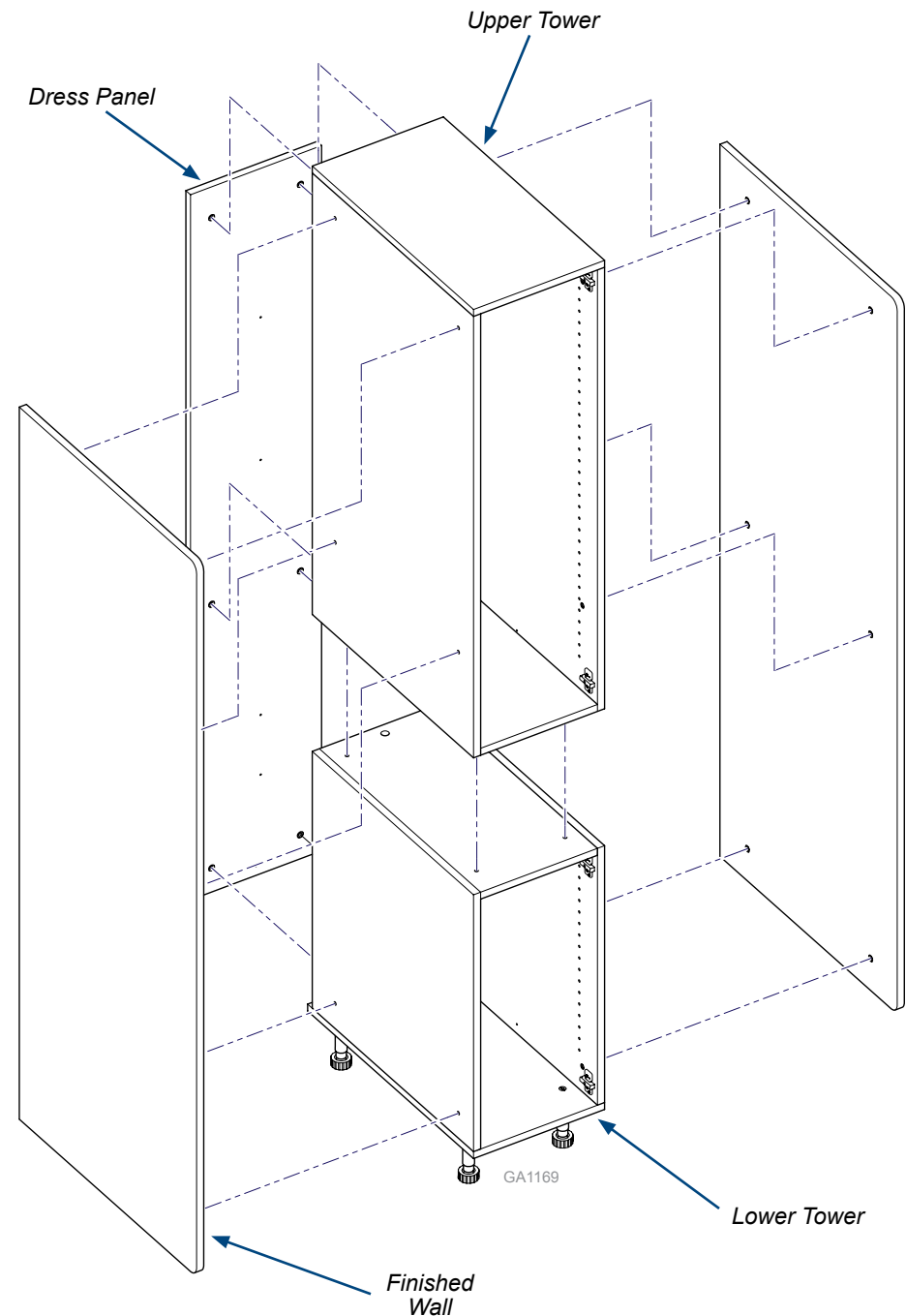
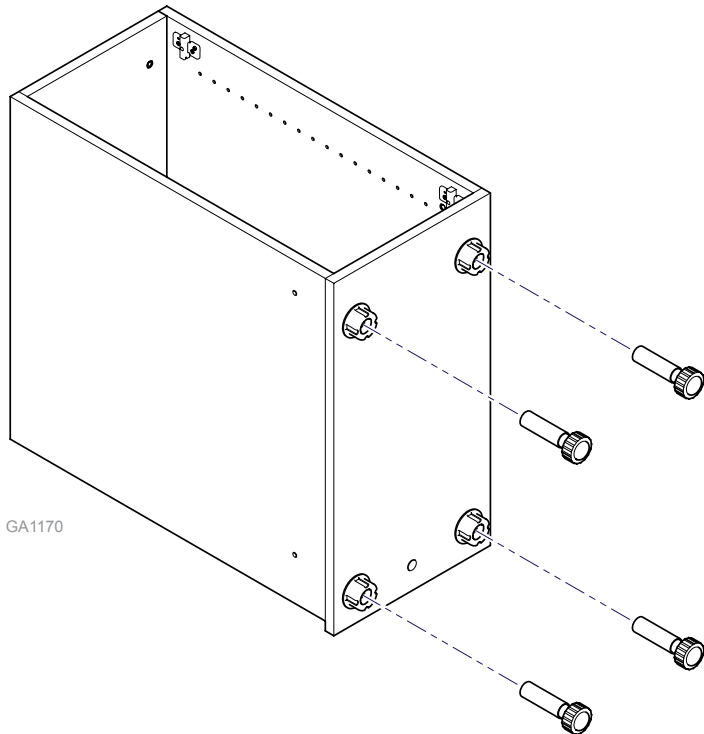

Base Cabinet Installation

Base Cabinet Installation

Step 1: Remove Base Cabinets From Pallet

- A) Remove base cabinets from boxes.
- B) Remove cabinet drawers (see Drawer Removal, Installation, and Adjustment in this manual)
- C) Remove cabinet doors, shelves, and false bottoms if applicable. (See Door Removal, Installation, and Adjustment in this manual)
- D) Tip cabinet onto its back and install the leg levelers.
- E) Adjust the leg levelers to 5-1/4" and stand cabinet upright when finished.
- F) Remove rear dress panels from boxes and attach to the back of each base cabinet using 1/4-20 X 1-1/4" LG machine screws.

Note

Custom casework designs may vary. General cabinet layout and assembly shown.

Note:

As a general rule, the connection hole type can be used as an indicator as to which hardware goes in what hole. Countersunk holes accept machine screws and holes without a countersink accept connection bolts.

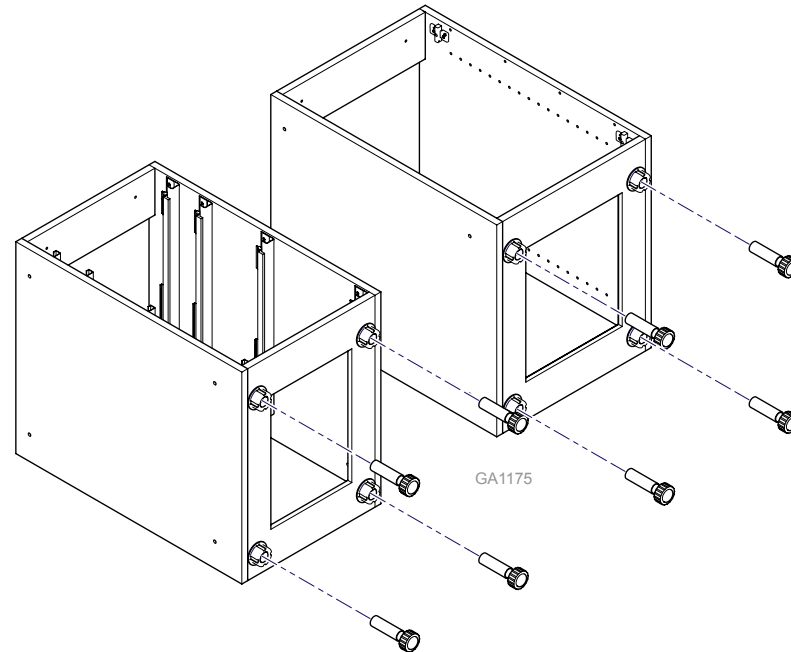
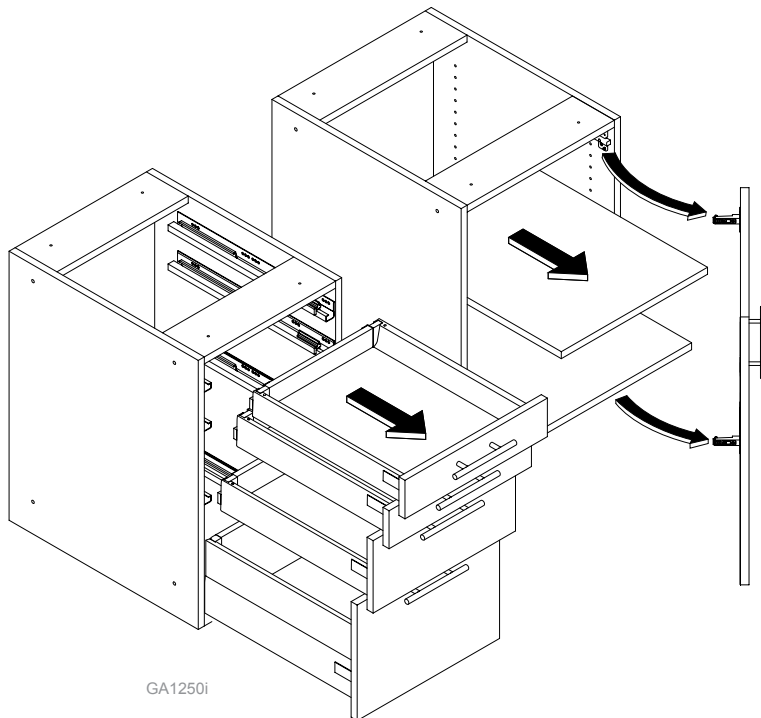
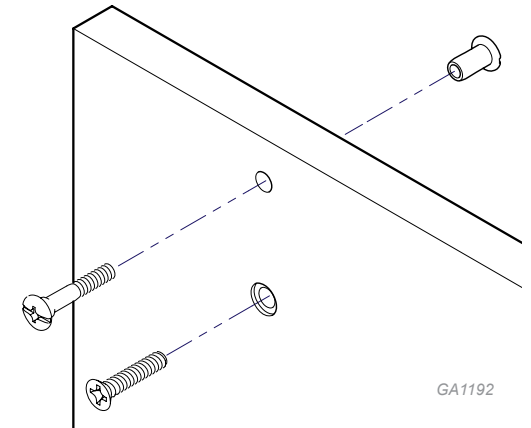

Base Cabinet Installation

Base Cabinet Installation

Step 2: Arrange and Make Base Connections

- A) Place base cabinet in desired location.
- B) Adjust cabinet height and level. See [Adjustable Camar Leg Leveler \(Cabinet Height Adjustment\)](#)
- C) Use either four 1/4-20 X 1-1/4" LG machine screws (for wall connections) or 4 connection bolts (for base cabinet connections) to attach cabinets. Ensure that cabinet shell fronts and bottoms are flush. Make fine adjustments to leg levelers as necessary.
- D) Repeat Steps 4 A-E and 5 A-D until base cabinet installation is complete.

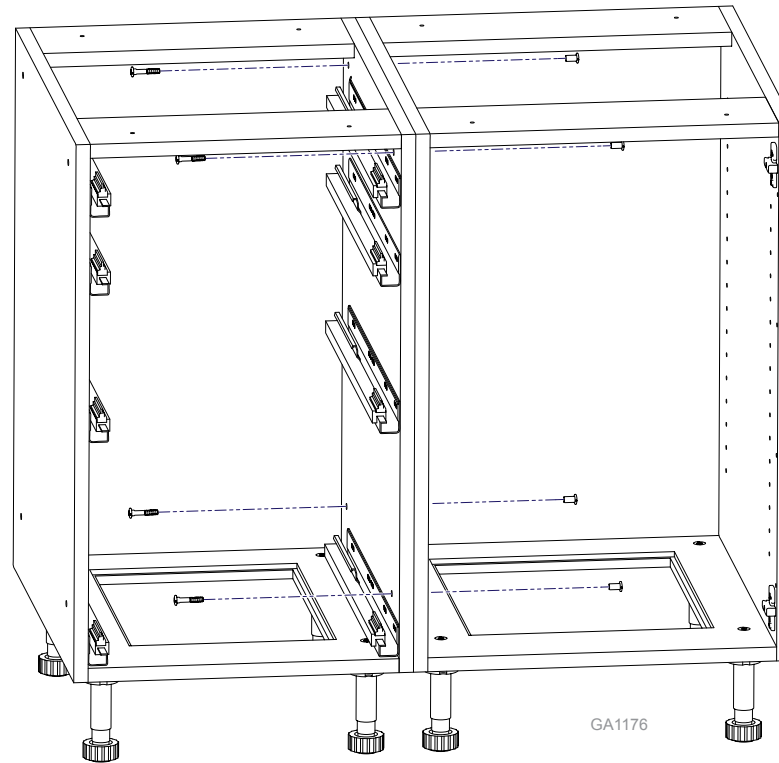

Equipment Alert

Adjusting both ends of the cabinet assembly may level the cabinets but will not support the load of the contents in the cabinet. Be sure that all leg levelers are adjusted such that they are in contact with the floor and thus supporting the load of the cabinets and its contents evenly.

Adjustable Camar Leg Leveler (Cabinet Height Adjustment)

- A) Insert a flat head screwdriver into the hollow bolts found in the bottom of a cabinet. Turn screwdriver clockwise to extend the leg, and turn counterclockwise to retract the leg.

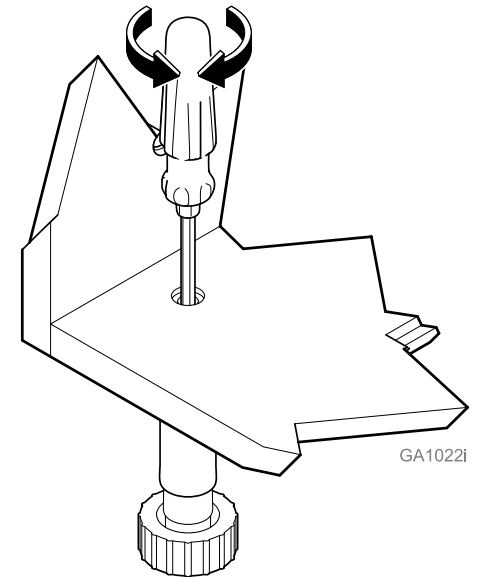

Hang Rail Installation

Step 3: Installing the Hang Rail

- A) Remove the hang rail from the packaging.
- B) Align the holes in the hang rail with the dado on the rear dress panels and attach with #8 X 3/4" flat head phillips at each end and every 8" or less.

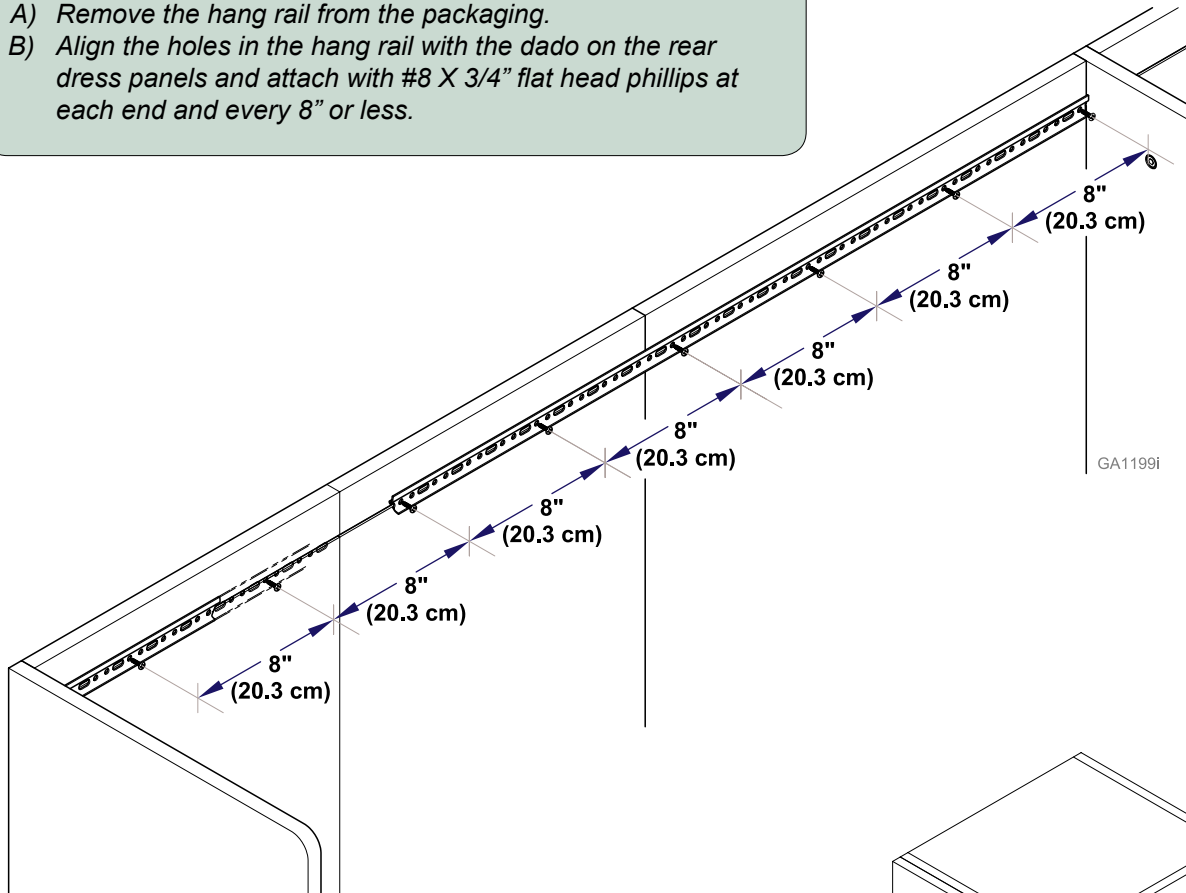

Step 4: Un-box Upper Cabinets

- A) Cut straps and remove shipping materials.
- B) Remove doors and shelves. See [Door Removal, Installation, and Adjustment](#) in this manual.



Caution

Upper cabinets may require 2 people to safely lift into position due to large size and/or weight.

Note

Do not fasten hang rail to the back panel less than 1 inch to the edge of the panel. If 8 inch spacing lands on a seam then use a 6 inch spacing where necessary.

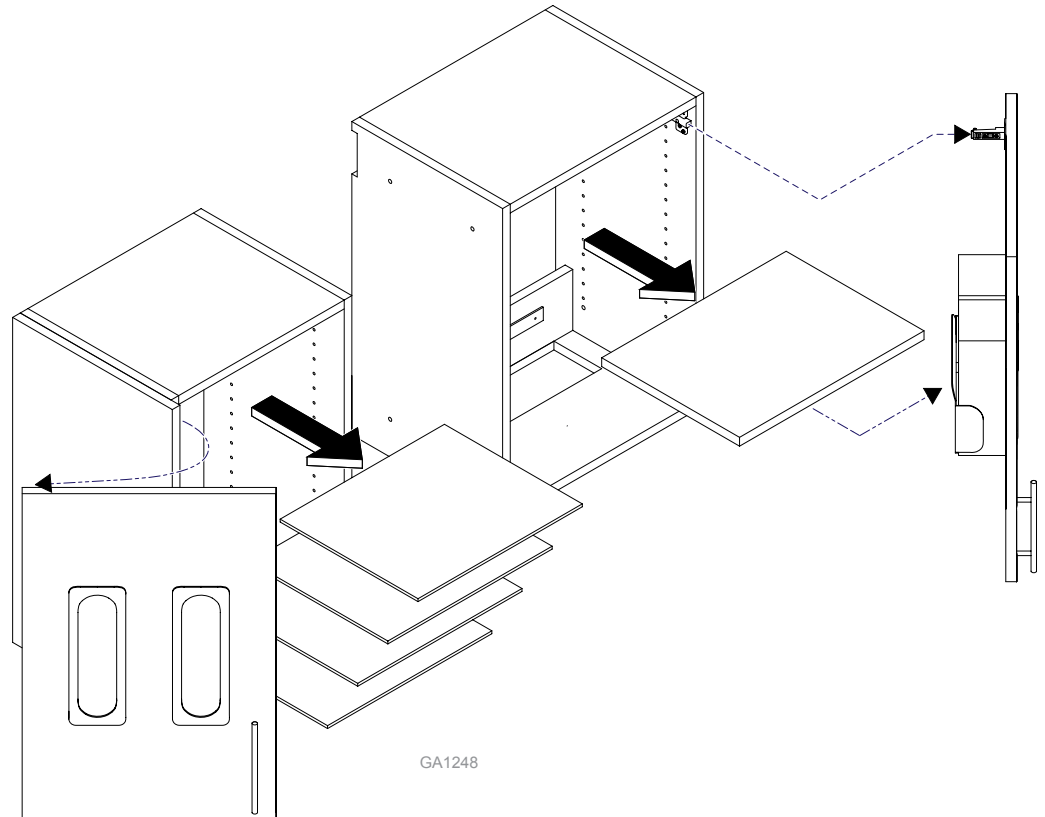

Installation (Freestanding Sterilization Casework)

Step 3: Upper Installation

- A) Adjust the cabinet hangers to the extended position in each cabinet.
(See [Hang Block Adjustments](#) in this manual)
- B) Hang upper on hang rail first next to a tower cabinet then continue off of the previous cabinet.
- C) Adjust the hangers in each cabinet until 1/16" gap is between the cabinet and the dress panel.
- D) Using a level, adjust the hangers to level the cabinet before tightening.
(See [Hang Block Adjustments](#) in this manual)
- E) Use either (4) 1/4-20 X 1-1/4" LG machine screws (for wall connections) or (4) connection bolts (for upper cabinet connections) to attach cabinets. Ensure that cabinet shell fronts and bottoms are flush. Make fine adjustments to hang blocks as necessary to level cabinet assembly.
- F) Continue by repeating steps 3 A-E until upper run of cabinets is complete.

Note: Be sure the face and top of each cabinet shell is flush before completing cabinet connections.

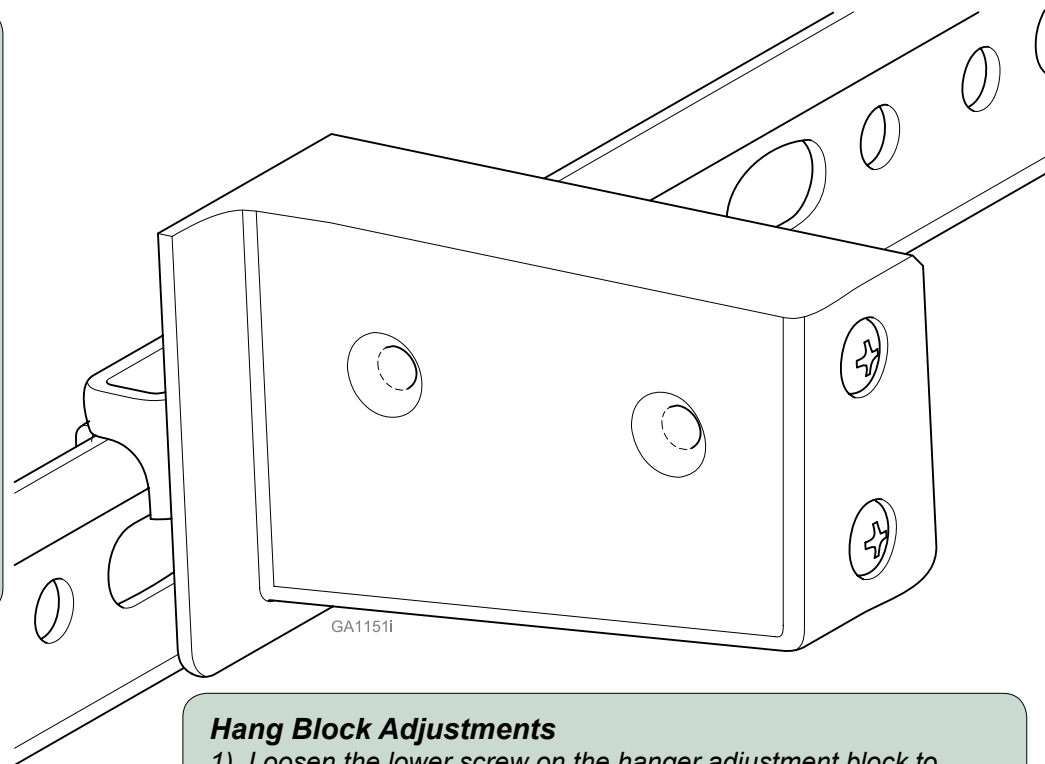
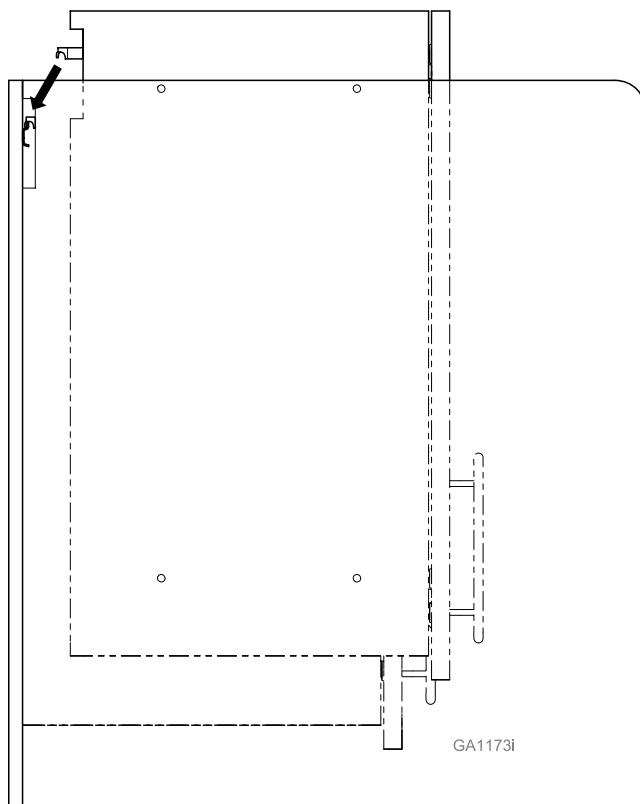

Hang Block Adjustments

- 1) Loosen the lower screw on the hanger adjustment block to extend the hanger outward equally beyond the back of the cabinet. (Clockwise retracts and counterclockwise extends the hanger.)
- 2) The top screw is used for vertical adjustment. Do not over tighten. (Clockwise raises the cabinet and counterclockwise lowers the cabinet.)



Equipment Alert

Adjusting both ends of the run of upper cabinets may level the cabinets but will not support the rated load. Be sure that all the Hang Blocks are adjusted vertically such that they are supporting the load of the cabinets evenly.



Caution

Verify that all the hangers are hooked on the rail before fully retracting the hangers. (See [Hang Block Adjustments](#) in this manual)

Installation (Freestanding Sterilization Casework)

Step 6: Electrical Connections

- A) Route metal clad cable through the wire chase and into the sink base.
See electrical specifications in this manual.

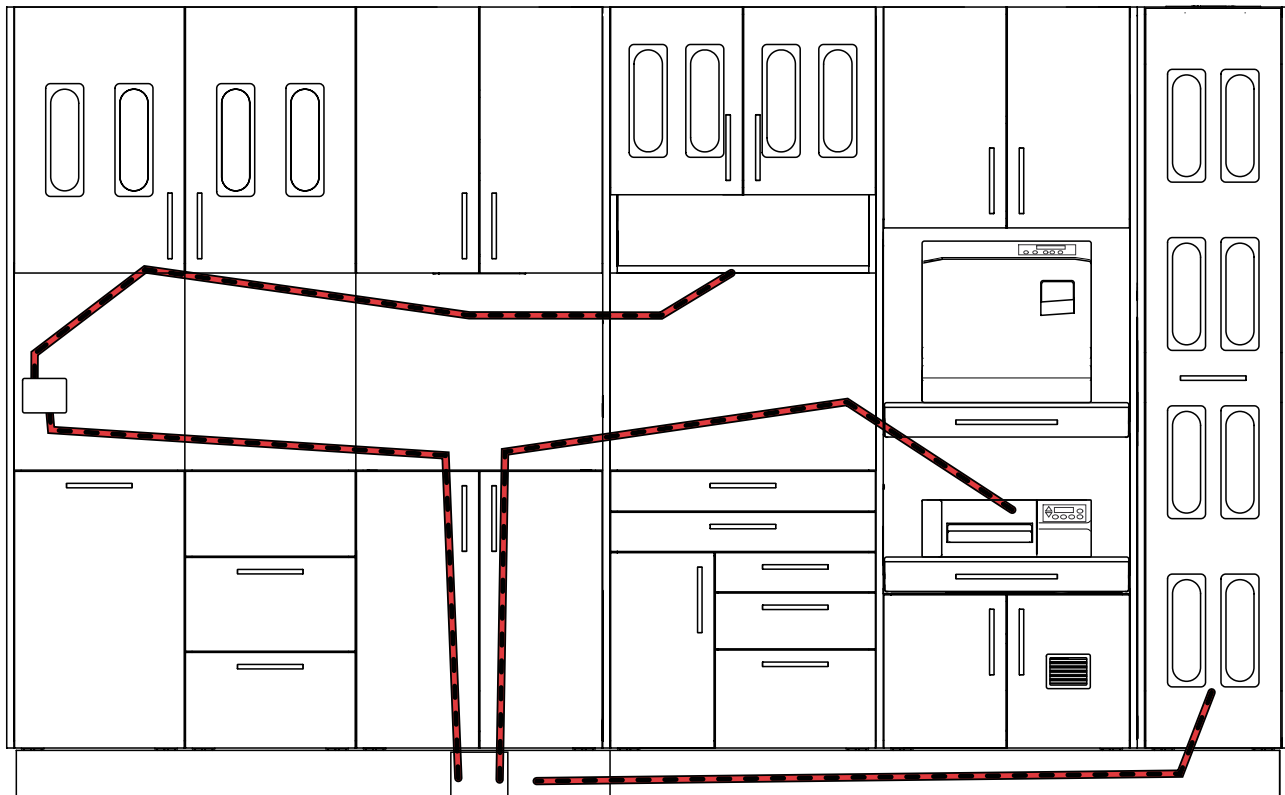

GA1198f

Step 7: Electrical Connections

- A) Install the finished back panels by inserting the bottom of the panel into the slot in the top of the cabinet sides. Tip the panel upright and press into the keku fasteners until they snap into place.

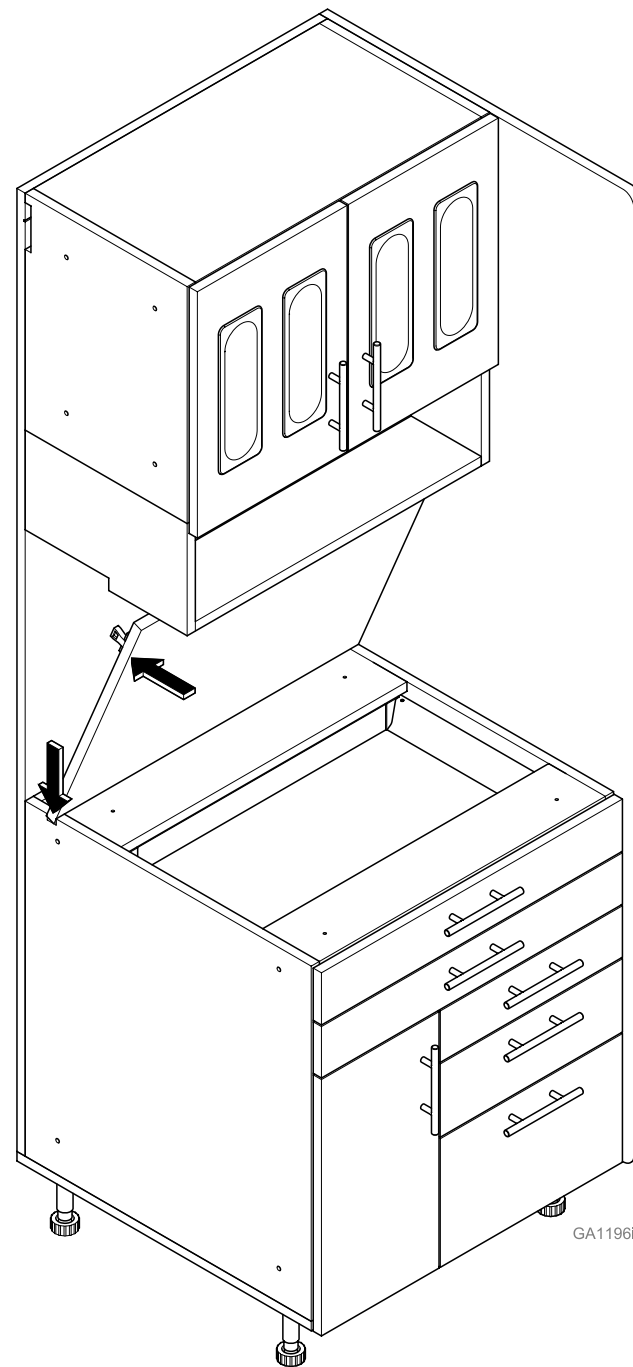

GA1196f

Countertop Installation (Freestanding Sterilization Casework)



Equipment Alert

Countertops need support at sink and other large cutout locations while being moved. Be sure to support the weight of the countertop with an extra person on either side of large cutouts.

Note:

For corners with dead space, frame up a rear countertop support or wall cleat to properly support the weight of the countertop at the wall.

Note:

For solid surface countertops that require a field seam, contact a solid surface fabricator to complete the seam using standard techniques and materials. Solid surface adhesive has been included with the countertop to appropriately match the color of the countertop.

Step 8: Solid Surface Countertop Installation

- A) Remove countertop from packaging and place on cabinets.
- B) If field seam is required, a solid surface fabricator should do so at this point.
- C) Adjust the countertop against the wall and overhanging the side of the cabinet by a 1/2" if on a finished end.
- D) In general, use the supplied 1" drywall screws to fasten L-brackets to the countertop and 1-5/8" screws through pre-drilled holes in the tops of all other cabinets.
- E) If backsplashes and/or sidesplashes are included, attach with silicone and clean off any excess.

Note: If countertop has blemishes after installation see [Cleaning and Maintenance \(Solid Surface\)](#) in this manual.

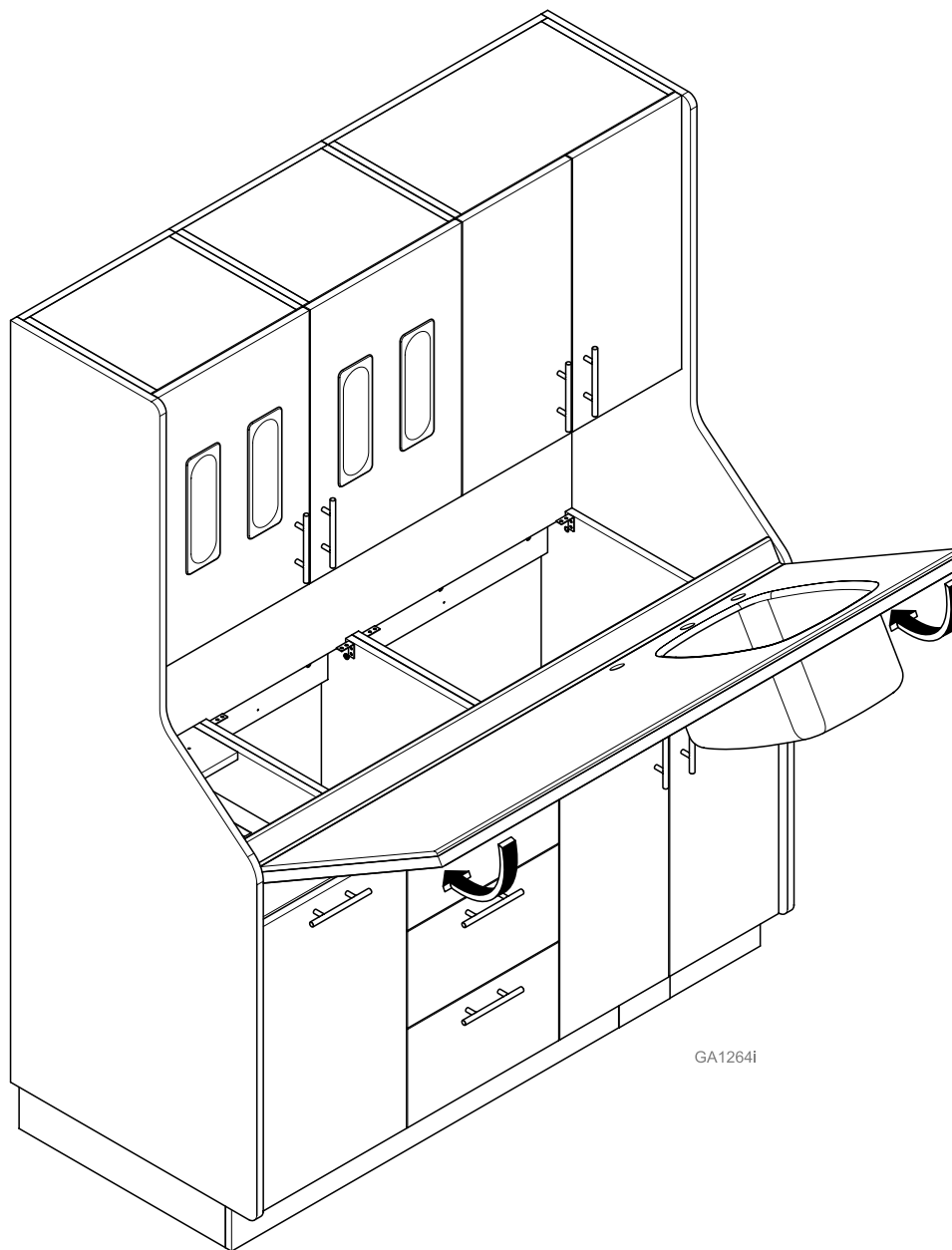

GA1264i

Countertop Installation (Freestanding Sterilization Casework)



Equipment Alert

Countertops need support at sink and other large cutout locations while being moved. Be sure to support the weight of the countertop with an extra person on either side of large cutouts.

Note:

For corners with dead space, frame up a rear countertop support or wall cleat.

Step 8: Laminate Countertop Installation

- A) Remove countertop from packaging and place onto cabinets.
- B) If field seam is needed...
 1. Place countertop seam together and make adjustments to the provided clamping H-bolts and clamp seam together.
 2. Remove clamping H-bolts and space seam a few inches apart.
 3. Use the provided adhesive caulk on the seam joint.
 4. Push both tops together and use the adjusted clamping H-bolts to clamp the countertop together.
 5. Move countertop into final position and use a rubber mallet to make fine adjustments to the seam to ensure that the joint is flush on the top as well as the front edge.
- C) Adjust the countertop against the wall and overhanging the side of the cabinet by a 1/2" if on a finished end.
- D) In general, use the supplied 1" drywall screws to fasten L-brackets to the countertop and 1-5/8" screws through pre-drilled holes in the tops or stretchers of all other cabinets.
- E) If backsplashes and/or sidesplashes are included, attach with silicone and clean off any excess.

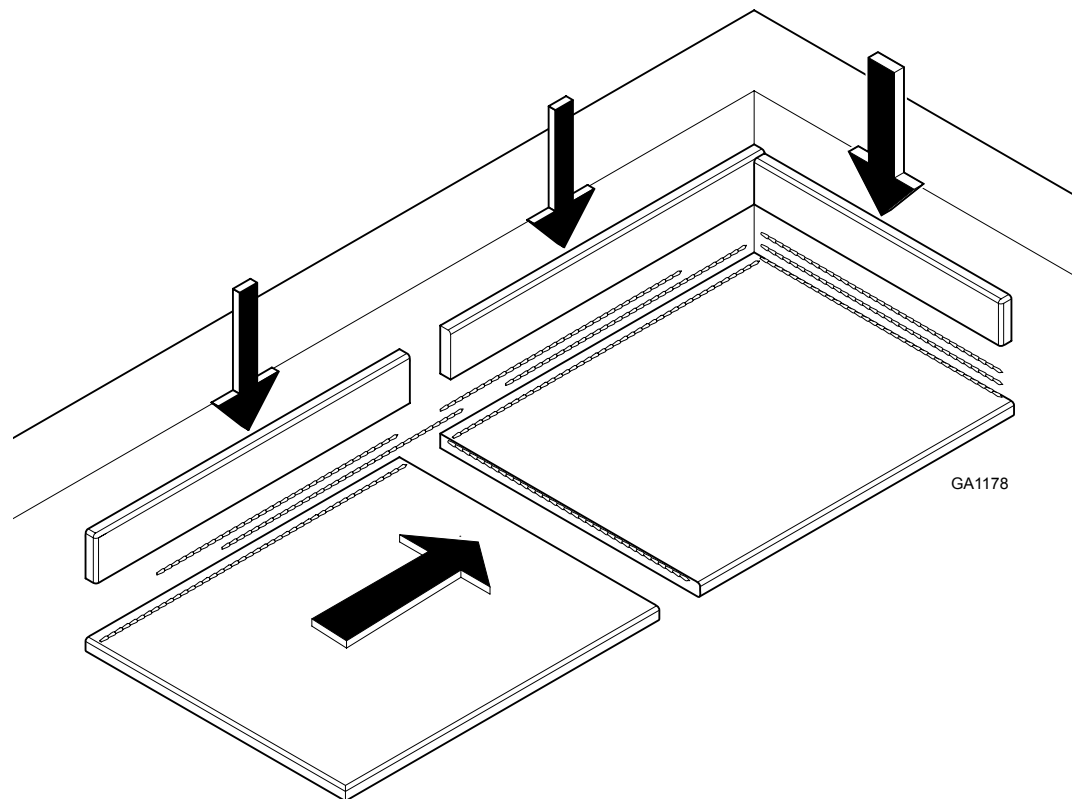

Step 8: Quartz Countertop Installation

- A) Remove countertop from packaging and place onto cabinets.
- B) If field seam is needed...
 1. Place countertops a few inches apart on the cabinets.
 2. Use a clear or appropriately colored silicone on the seam joint.
 3. Push both tops together.
 4. Move countertop into final position and use shims under the countertop to make any final adjustments to make the seam flush.
- C) Using a bead of silicone inside of the end cabinets, attach the countertop to the cabinets.
- D) If backsplashes and/or sidesplashes are included, attach with silicone and clean off any excess.

Installation (Freestanding Sterilization Casework)

Step 9: Install Toe Kick (If not Stainless Steel Base)

- A) Remove toe kicks from packaging. (Typically packaged with countertop.)
- B) Install Tapmaster® if necessary. See [Tapmaster® Installation](#) in this manual.
- C) Lay the toe kick face down in front of the leg levelers with the rabbet away from the cabinets.
- D) Align the plastic receivers with each leg and tap them into the dado in the back of the toe kick by using a rubber mallet.
- E) Install the metal leg clips into the plastic receiver.
- F) Tip the toe kick assembly up 90° and press onto the leg levelers until the metal leg clips snap into place.
- G) If stainless steel finish, remove protective plastic film.

Note: If stainless steel toe kick needs cleaning use an oil based cleaner or polish.
E.g. Sheila Shine.

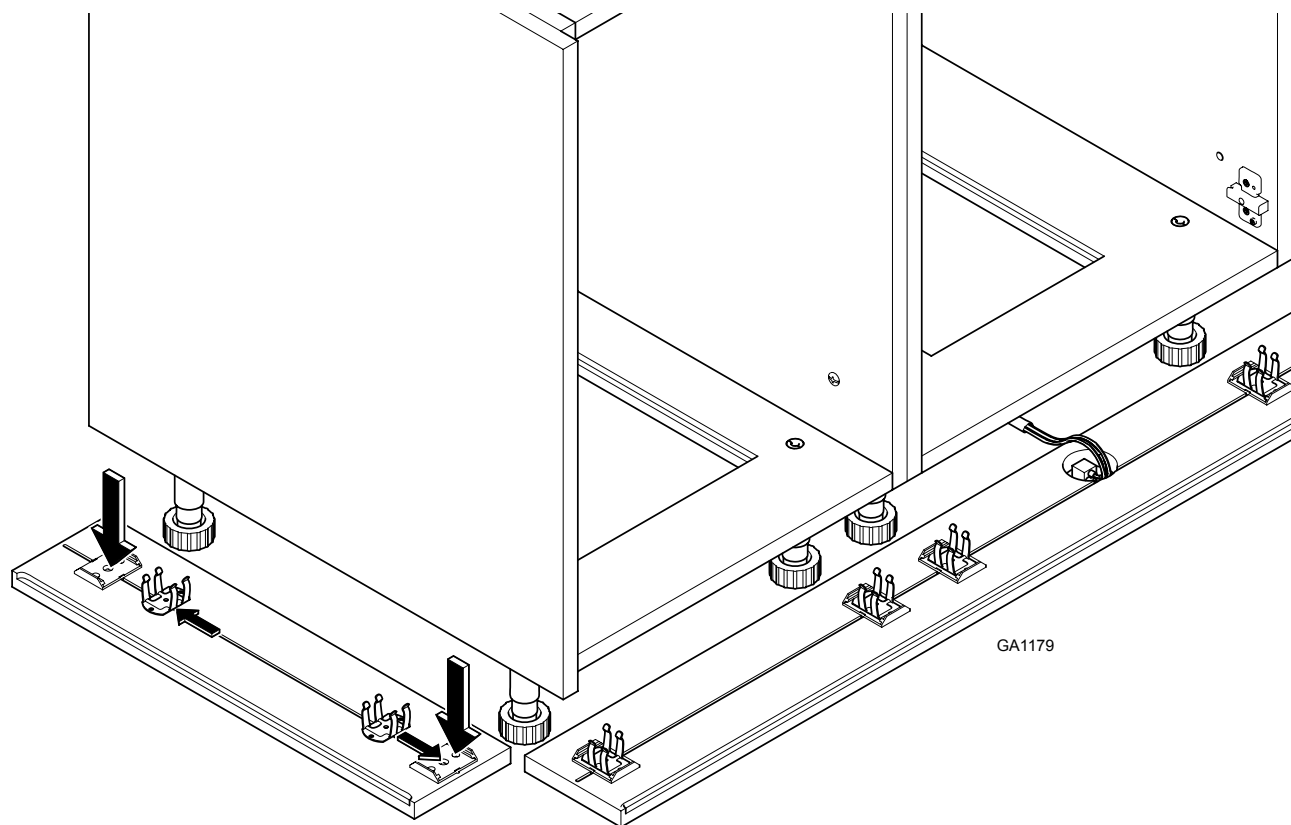
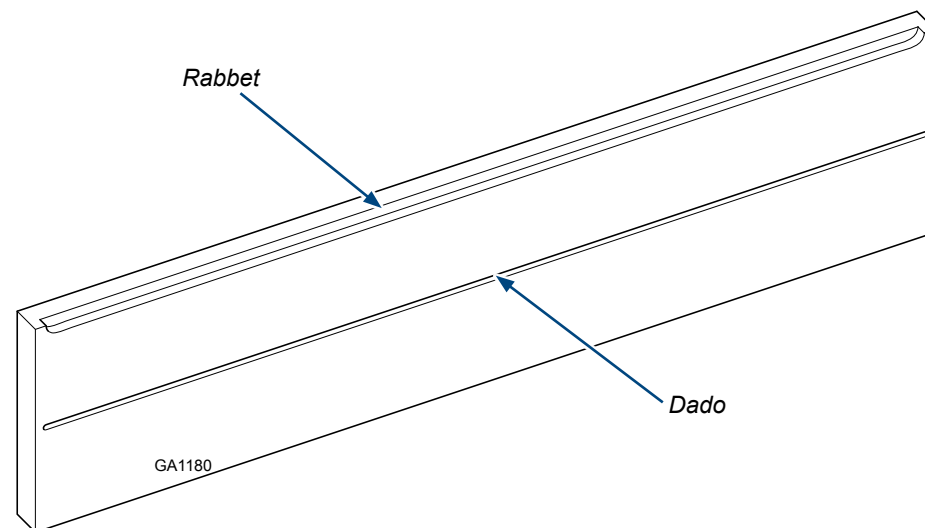

Tapmaster® Installation

Tapmaster Install...

- A) Remove hex head nut from valve block and leave the second nut and lock washer on the valve body.
- B) Insert the threaded valve body through the provided hole in the stainless steel base or mounting plate (If in a toe kick application.)
- C) Use the hex nut and tighten so that the nut is flush with the face of the valve body.
- D) Make additional valve body installations if necessary.
- E) Route water valves to sink base and allow a plumber to make connections.

Note: See instructions included in Tapmaster kit for additional install, operation, and troubleshooting information.

Note:

Knee activated Tapmaster® comes factory pre-installed onto cabinet. Only plumbing connections required.

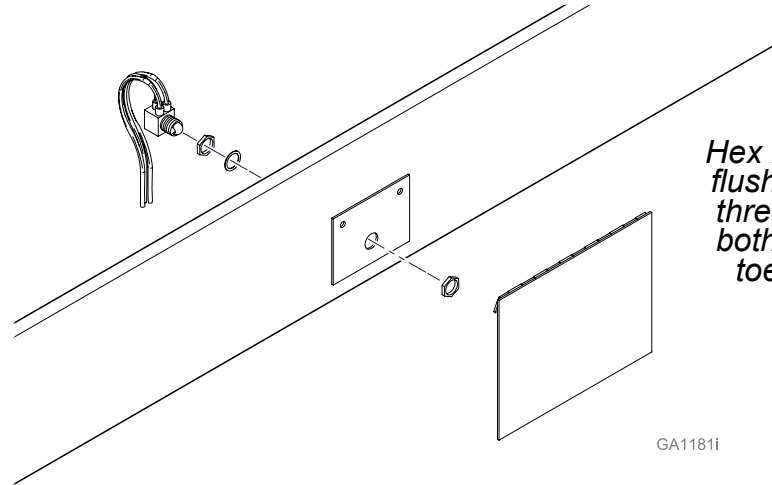

Hex nut is to be mounted flush with the face of the threaded valve body for both stainless steel and toe kick applications.

Cabinet Accessories

Towel or Towel / Cup Dispenser Install

- A) Hang dispenser on the mounting bracket in applicable upper cabinets.

Note: Use C-fold towels and cups with a major diameter of 2-1/2"

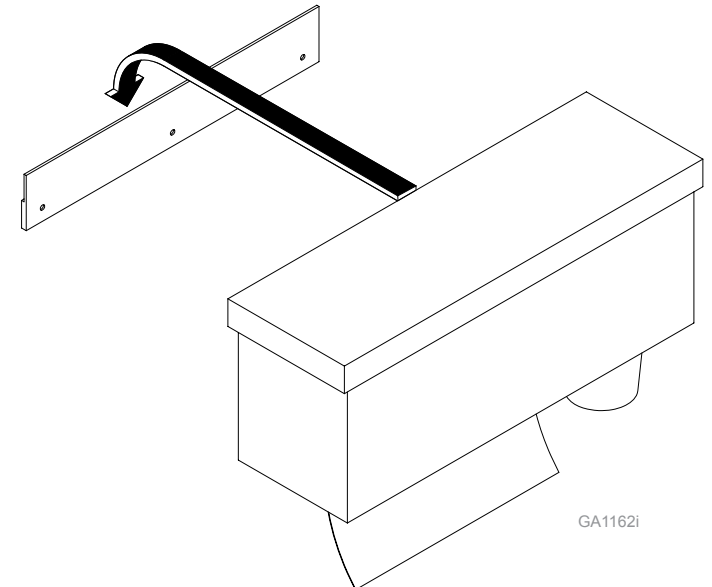

Installation (Freestanding Sterilization Casework)

Step 10: Doors and Drawers

- A) Re-install cabinet drawers (see Drawer Removal, Installation, and Adjustment in this manual) and make adjustments as needed.
- B) Install shelves.
- C) Re-install cabinet doors (see Door Removal, Installation, and Adjustment in this manual) and make adjustments as needed.

Note: Use rubber bumper shelf pegs for glass shelves and locking shelf pegs in pass through applications where shelf movement must be restricted.

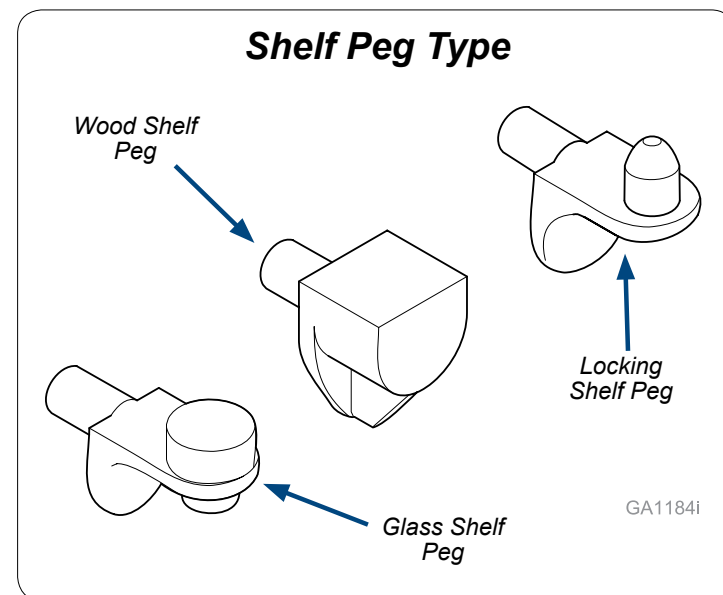
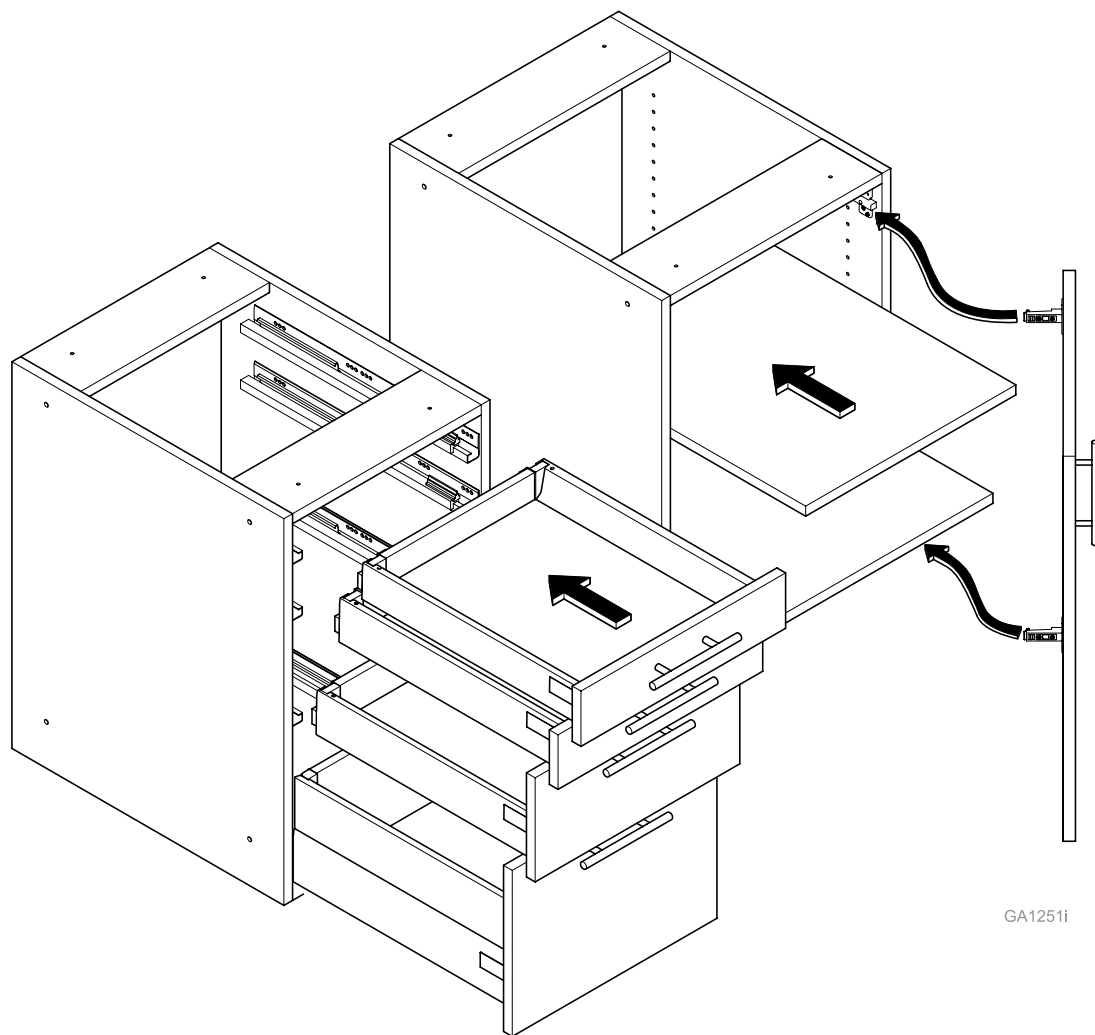

Drawer Removal, Installation and Adjustment

Drawer Removal

- A) Open drawer completely.
- B) Lift up on the drawer front until the front of the box releases from the glide.
- C) Pull out on the drawer slightly.
- D) Lower the drawer back down while pulling out on the drawer.

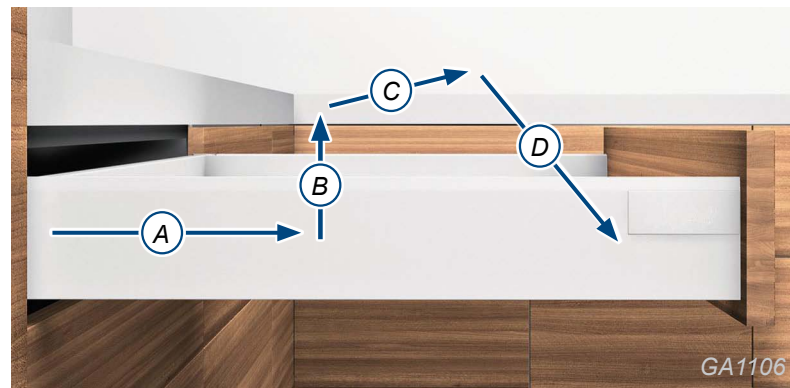

Drawer Installation

- A) Fully extend drawer glides from the cabinet. (Optional)
- B) Place the drawer on the glides.
- C) Push the drawer in completely.
- D) Cycle drawer a couple times to ensure that the drawer is securely attached to the glides.

Full Extension Glide Removal & Installation...

Removal

- A) Extend the glide to its outermost position. Push the release levers in and remove the drawer member of the sides.

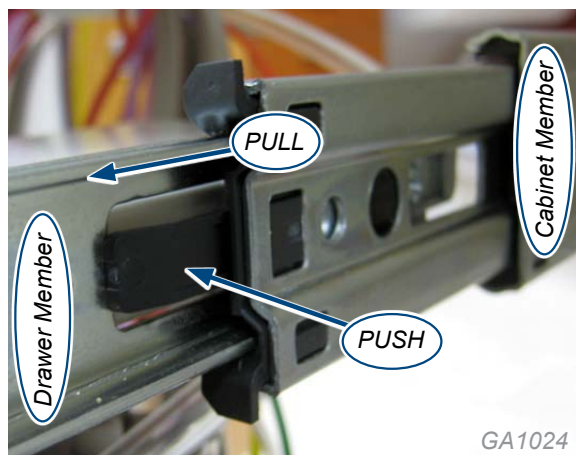

Installation

- A) Line up the drawer member to the cabinet member and push the drawer into its compartment.

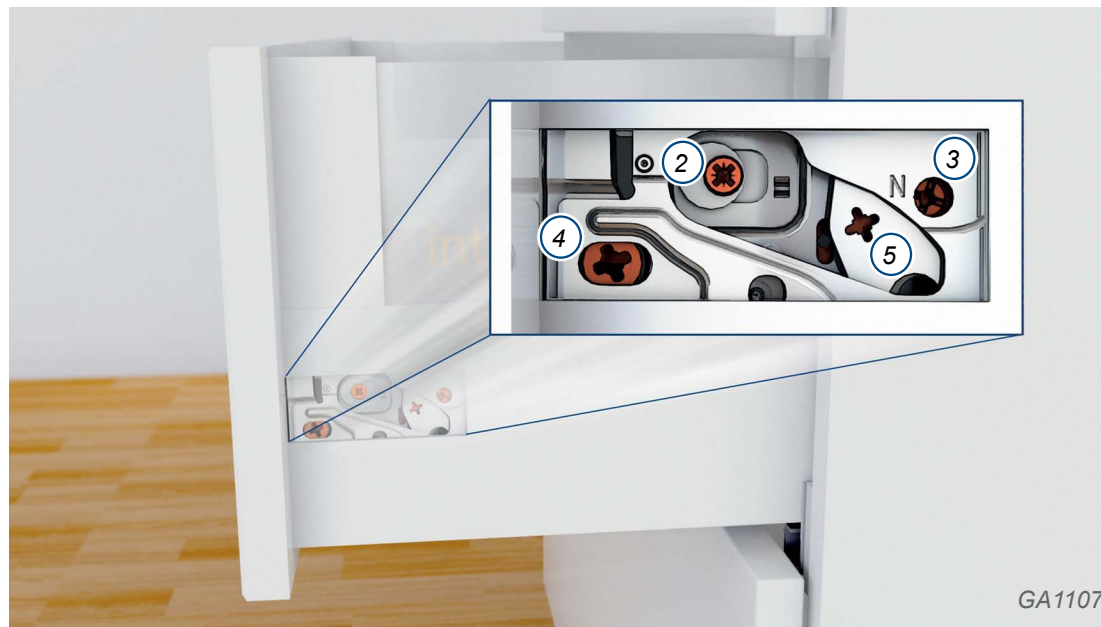

Drawer Front Adjustment and Removal

- 1) Remove the cover caps on the drawer side by hand.
- 2) Height Adjustment: Rotate in either direction to adjust the drawer front vertically.
- 3) Tilt Adjustment: Adjust after the drawer front is installed to ensure the drawer sides meet square with the drawer front. (Only available on large drawer boxes.)
- 4) Side Adjustment: Adjusts the drawer front horizontally. Turn in either direction.
- 5) Tension/Removal: For large drawers, turn the screw toward the front of the drawer until the front detaches from the box. Repeat this procedure on both sides of the drawer. For small and medium drawer boxes, turn the screw toward the back of the drawer to remove the front.

Door Removal, Installation, and Adjustment

Hinge 1 & 2 Adjustments

Use a phillips head screw driver for the following steps...

- Screw A adjusts the door in direction A seen in the Adjustment Direction Guide
- Screw B adjusts the door in direction B. Equal adjustment must be made to all hinges on the door for it to move the desired distance.
- Screw C adjusts the door in the C direction. Make adjustments to top and bottom hinge as necessary.

Note: Use a level to ensure the door is level and plumb. Preferred gaps are approximately 1/8" between doors and 1/16" between accents and doors.

Hinge 1 & 2 Removal

- Press button at point E at the back of the hinge and pull away from cabinet.

Hinge 1, 2, & 3 Installation

- Hook the hinge to the mounting block at point F
- Latch at point G by pressing the hinge against the hinge block.

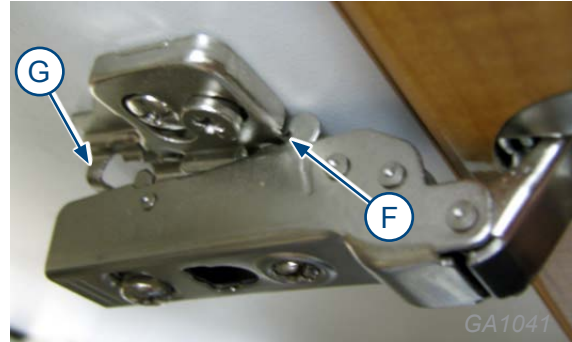

180° Hinge Adjustments

- Loosen screw D and adjust door gap and angle using a level. Tighten screw D when positioned correctly,

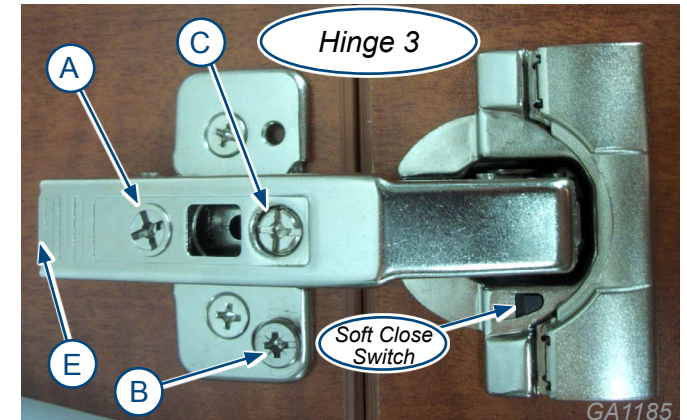
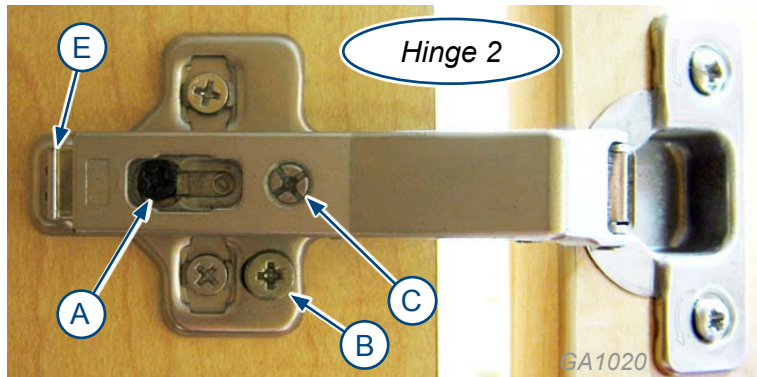
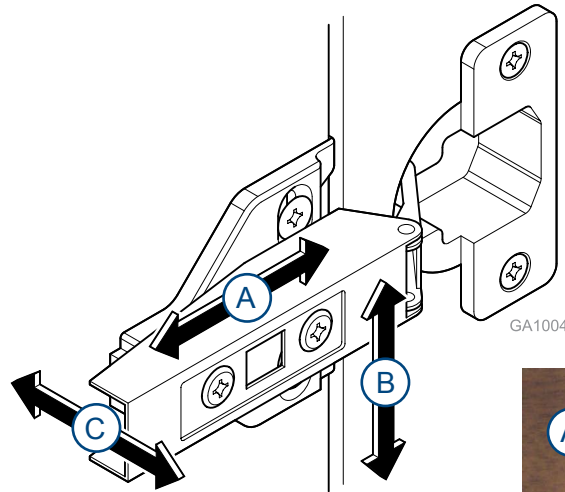
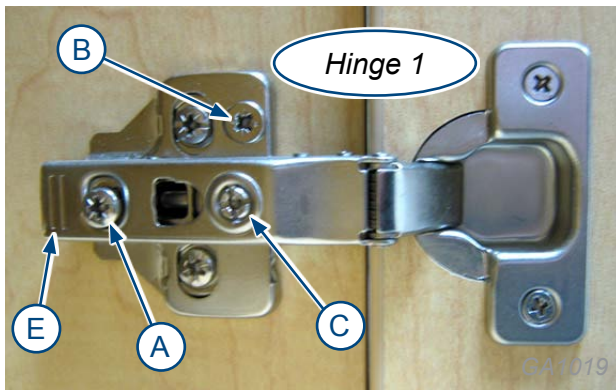
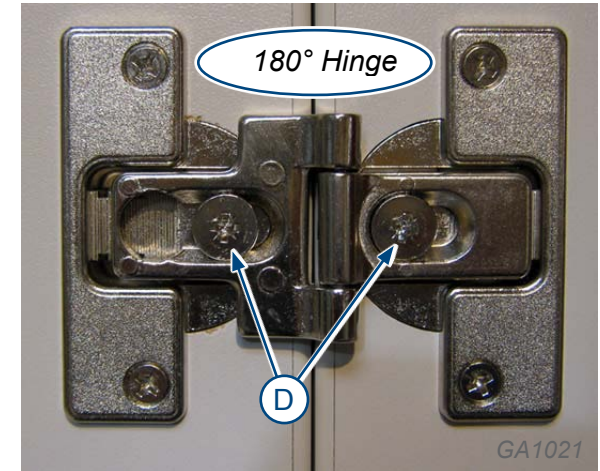

Electrical Diagrams (Freestanding Sterilization Casework)



Equipment Alert

Important Notice: This unit must be wired to a GCFI protected circuit.

Handy Box 027-1681-00
(used primarily in Drawer, Shelf or Ultrasonic bases)

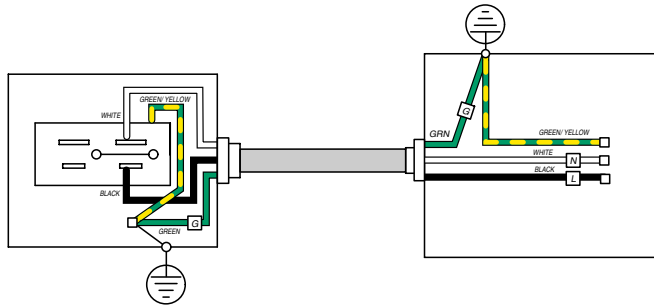

Sterilization Tower 027-1683-00

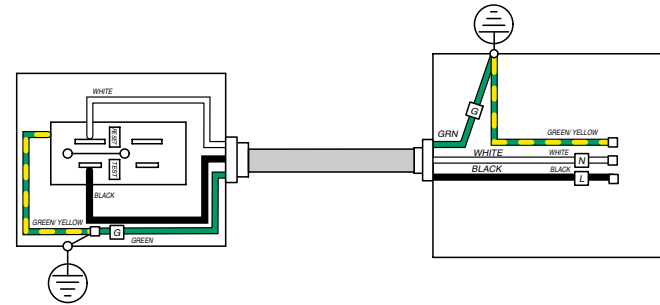

Clean Tower 027-1680-00

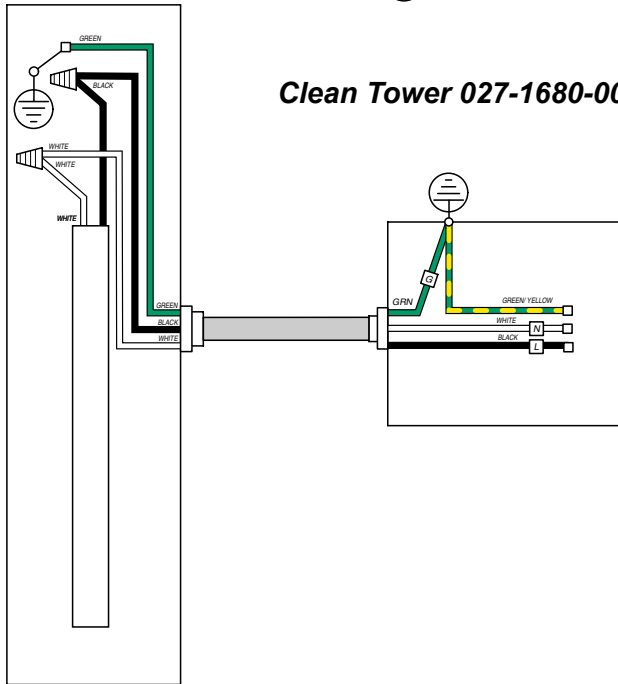

Storage Pantry Tower 027-1689-00

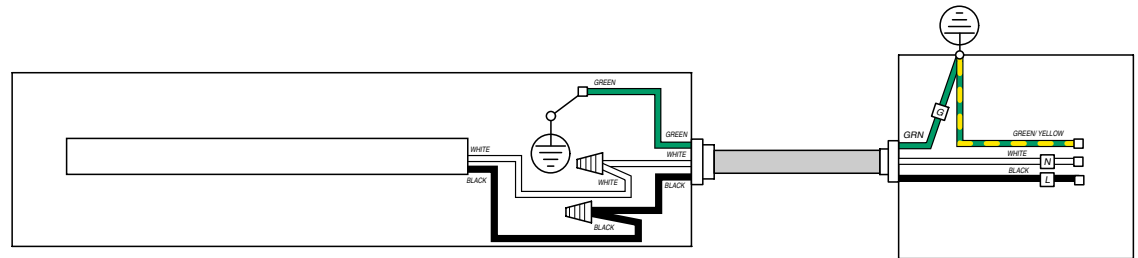

GA1253i

Note

Only Licensed Electricians following local and applicable electrical codes should install and connect the electrical supply power. Midmark cannot be held responsible for installations that do not conform to local codes.

Electrical Diagrams (Freestanding Sterilization Casework)



Equipment Alert

Important Notice: This unit must be wired to a GCFI protected circuit.

SC96-200 / SC120-200 / SC144-200 (w/ Task Light & Interior Lighting)

SC96-200 / SC120-200 (w/ Task Light)

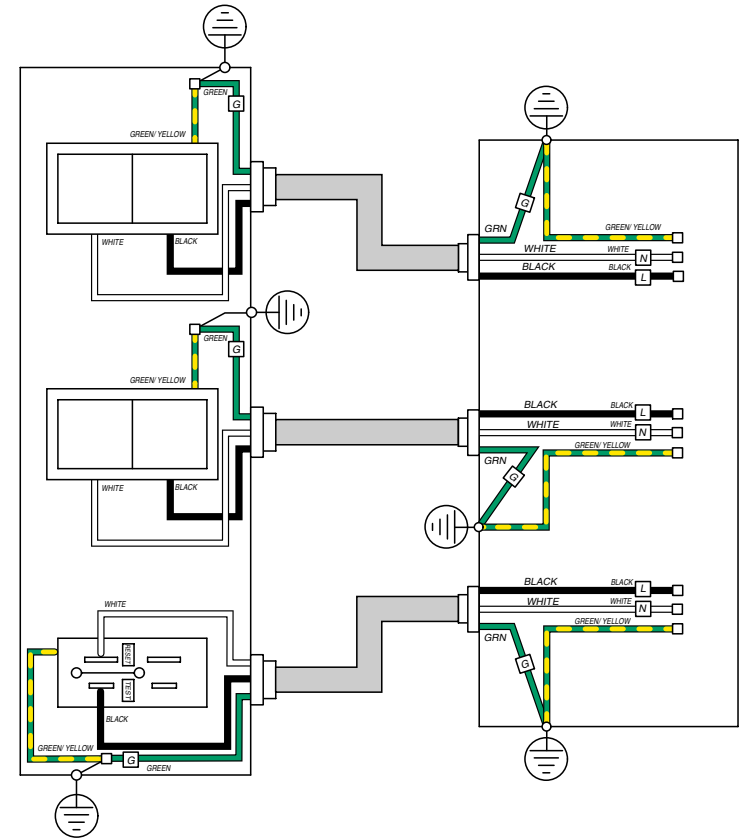
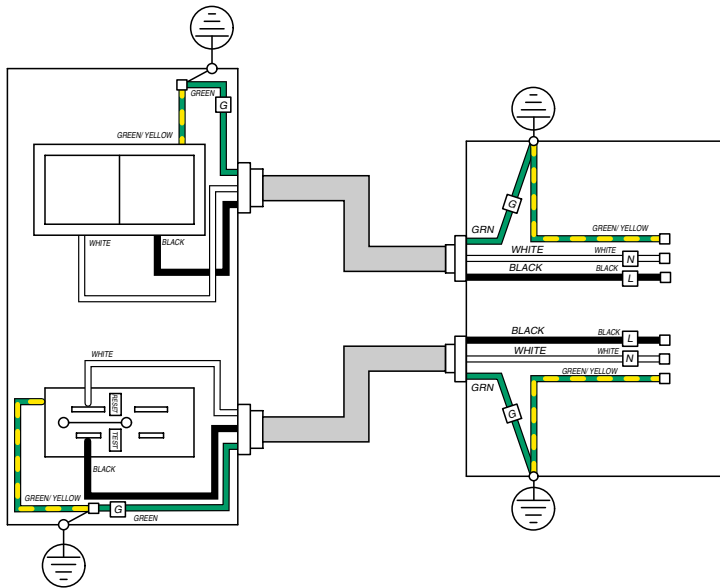

Note

Only Licensed Electricians following local and applicable electrical codes should install and connect the electrical supply power. Midmark cannot be held responsible for installations that do not conform to local codes.

GA1265i

Cleaning / Maintenance (Casework)

Disinfecting Procedures for External Surfaces

Attention!

Midmark assumes no responsibility or liability for any result, expressed or implied. These are suggested practices, based on the best information available at this time.



Equipment Alert

- Users should not use cleaning or decontamination methods different from those recommended by the manufacturer without first checking with the manufacturer that the proposed methods will not damage the equipment.
- Midmark's dental equipment is manufactured from the most chemical-resistant materials available. However, no material is impervious to every chemical. Using protective barriers is the most effective method to prevent equipment damage.
- Use only moist cloth with appropriate cleaner for cleaning casework.

Cleaning and Disinfectant Procedures

Use cleaners and disinfectants that are appropriate for the situation such as warm water and mild detergents, or an ammonia based cleaner.

NOTE: Every dental practice is different, and no single disinfectant is the best choice for every facility. Listed below are some organizations to assist you in choosing the best disinfectants available for your practice.

- Organization for Safety & Asepsis Procedures: <http://www.osap.org>
- American Dental Association: <http://www.ada.org>
- Dept. of Health & Human Resources Centers for Disease Control & Prevention (CDC): <http://www.cdc.gov>

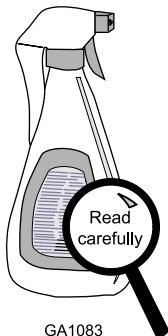

GA1083

When using disinfectants...

Carefully read the product label and directions for use.
Do not exceed the dilution rate.

Read all labels carefully!

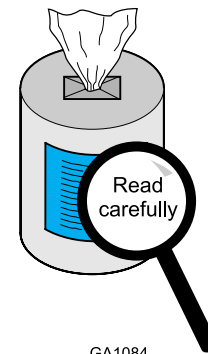

GA1084

Cleaning and Maintenance (Solid Surface)

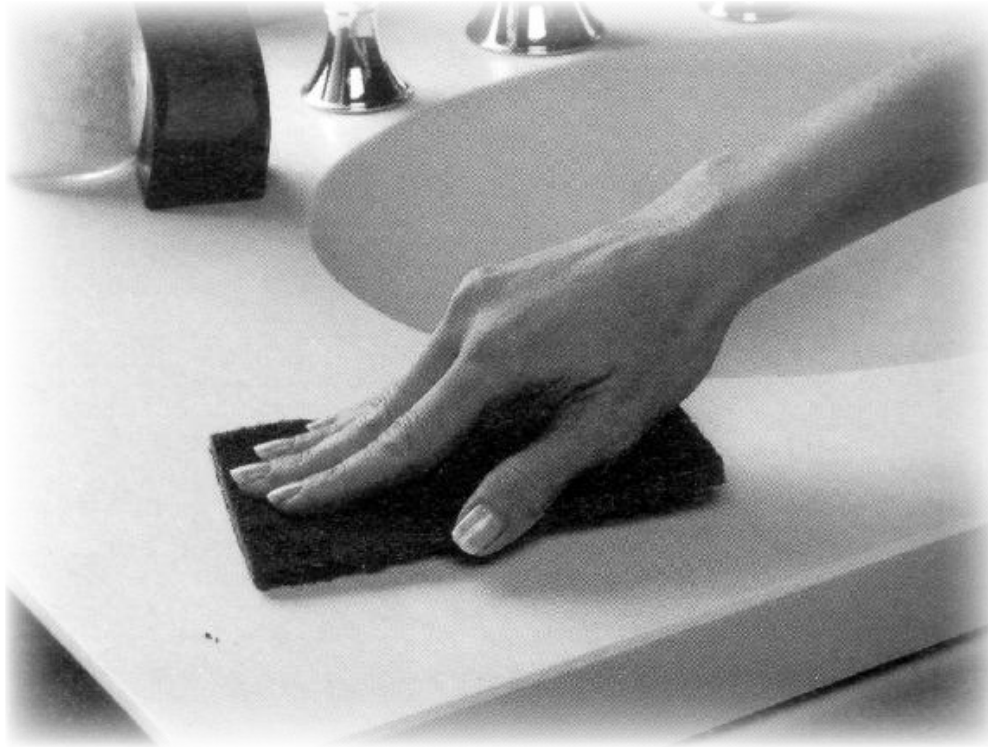

Caring for your Solid Surface countertop is as simple as wiping the surface with a damp cloth. If a stain develops, wipe it away with soap and water. Or if you prefer wipe it clean with ammonia based cleaner.

If a stain doesn't respond to soap and water, for a matte finish, apply an abrasive cleanser and buff with a Scotch-Brite pad using a circular motion. The same technique can be used for burns. **If you have a gloss finish, please contact your dealer or fabricator before attempting repairs.**

For minor cuts and scratches, simply sand lightly with a medium (220 grit) sandpaper, then follow with a fine (320 grit) sandpaper. Finally, touch up the finish by buffing with a Scotch-Brite™ pad.



Caution

Do not expose the surface to harsh chemicals, such as paint remover, turpentine, nail polish remover or stove and drain cleaners. If these chemicals come in contact with the surface, immediately wash them off with water, using appropriate safety measures to avoid injury.



Because we care.