



Installation Instructions for Back-to-Back FRP Sani- Kennel

Introduction

Thank you very much for your investment in Mason kennels. We take great pride in providing our customers with the highest quality animal enclosures combined with an enjoyable ordering experience. The following instructions will assist you with proper assembly, cleaning, and maintenance of your Mason kennels. It is important to follow these guidelines to receive the best results and maximum life from your investment.

Assembly

The following pages will show you how to assemble your new Mason kennel. Since every order is custom built to your specifications, the instructions are designed to show the various methods used to assemble our kennels and some of the demonstrations may not apply to your order. Be sure to use the enclosed scale drawings at the end of this document of the hardware provided to ensure proper identification and usage.

Hardware

Depending on your Kennel project you may have some or all of the following hardware:

Part #	Description	Part #	Description
2222	#10-32x 5/8" TEK screw(s)	8081	Triple SS clamp(s) -1" (w/stainless steel gate option)
2449	Sealant	8082	Double SS clamp(s) -1" (w/stainless steel gate option)
356	5/16" x 1-1/2" carriage bolt(s)	8083	Single SS clamp(s) -1" (w/stainless steel gate option)
357	5/16" x 1-3/4" carriage bolt(s)	330	Panel clamp (w/chain link gate option)
1771	5/16" x 1-3/4" SS carriage bolt(s)	328	Triple clamp (w/chain link gate option)
1955	5/16" x 1-1/2" SS carriage bolt(s)	8404	Large Corner Gusset
423	5/16" – 18 nut	8405	Small Corner Gusset
424	5/16" – 18 SS nut	8406	Long Panel Horizontal Gusset
369	1/4"-20 x 1-1/2" hex head bolt (w/stainless steel gate option)	8416	Long Panel Vertical Gusset
421	1/4"-20 nylok nut	366	1/4"-20 x 1" hex head bolt
422	1/4"-20 hex nut	891	#12 x 1" Hex Head Sheet Metal Screw
1400	1/4" x 1-1/2" Rawl spike(s) (anchored systems only)	8399	71.875" Panel Connection H
933	1/4"-20 x 1/2" round head screw	8400	83.875" Panel Connection H
2438	1/4"-20 x 1-1/4" truss head screw	8406	Wall Shim
454	1/4" Washer	6724	Gate Mounted Pulley Assembly
1468	Square to Round Clamp (w/chain link gate option)	6726	Wall Mounted Pulley Assembly

Aluminum Panel Attachment Angle (May be attached to side panels from factory in some cases)

“Sanislope T”

Note: Wall mounting hardware is shown only for reference purposes and is not included

Installation

Required installation tooling:

- Level (4' preferred)
- 1/2" combination wrench
- 7/16" combination wrench
- Hammer
- Hammer drill (anchored systems only)
- 1/4" masonry bit (anchored systems only)
- 5/16" drill bit (anchored systems only)
- #2 Phillips bit (2-3)
- Caulk gun
- Variable speed drill (cordless preferred)
- 11/64" drill bit
- Tape measure
- Chalk line
- Denatured alcohol
- Shop rags
- 5/16" nut driver bit

Optional tools

- Vise grips – 8" locking C-clamps (3 pair recommended)
- WD40 or other thread lubricant

Section A Panel Identification

Refer to the floor plan supplied.

Depending on the nature of your kennel project you will have either letter and or number designations on the tag(s) wired to the top of the panel as shown in Figure 1.

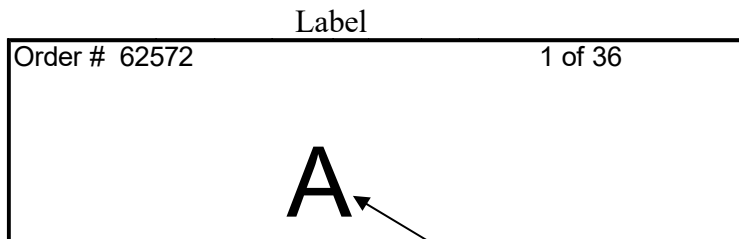

Letter / Number designation

Figure 1

Each connection point of the panels should be aligned as shown on the floor plan. Note the difference in the alignment of the two panel connections shown in Figure 2. It will make a difference as to how your runs go together if you do not align the panels properly, and in some cases, they may not go together at all.

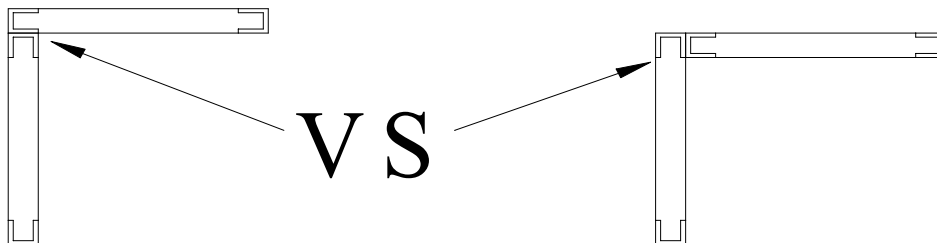

Figure 2

Section B Panel Assembly

Sometimes the length or layout of the division panels in a kennel requires that they be made up from multiple panels. Each of the multiple panel assemblies must be connected before assembling the runs. Referring to the Floor Plan and using the Panel Identification Tag as described in Section A, make all multi-division panel connections that are in line with one another using the following steps:

1. Place the rear division panel on the floor-T with the rear edge of the panel flush with the rear edge of the floor-T.
2. Set the Panel Connection H extrusion on the floor-T and slide it over the front edge of the rear division panel.
3. Using six of the #10-32 x 5/8" TEK screws provided, secure Panel connection H extrusion to the rear panels. (Three screws should be used for each side of the panel, one each in the top middle and bottom). See Figure 3A.

Note: To avoid screw interference, offset the screw location by 1/4 - 3/4" on either side of the panel

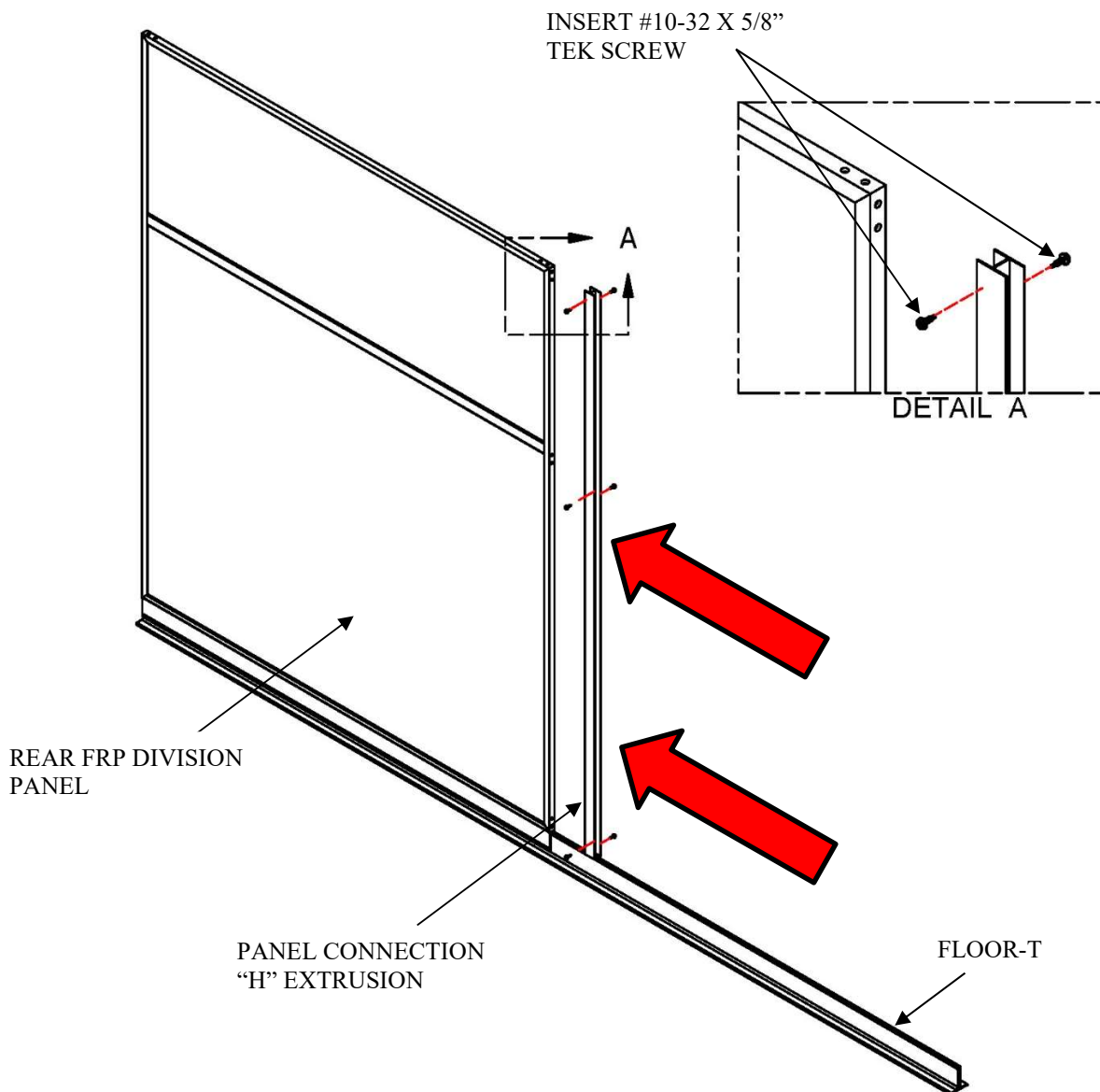

Figure 3A

- Place the front division panel on the floor-T and slide it into the Panel Connection H extrusion.
- Using six of the #10-32 x 5/8" TEK screws provided, secure Panel connection H extrusion to the rear panels. (Three screws should be used for each side of the panel, one each in the top middle and bottom). See Figure 3B.

Note: To avoid screw interference, offset the screw location by 1/4 - 3/4" on either side of the panel

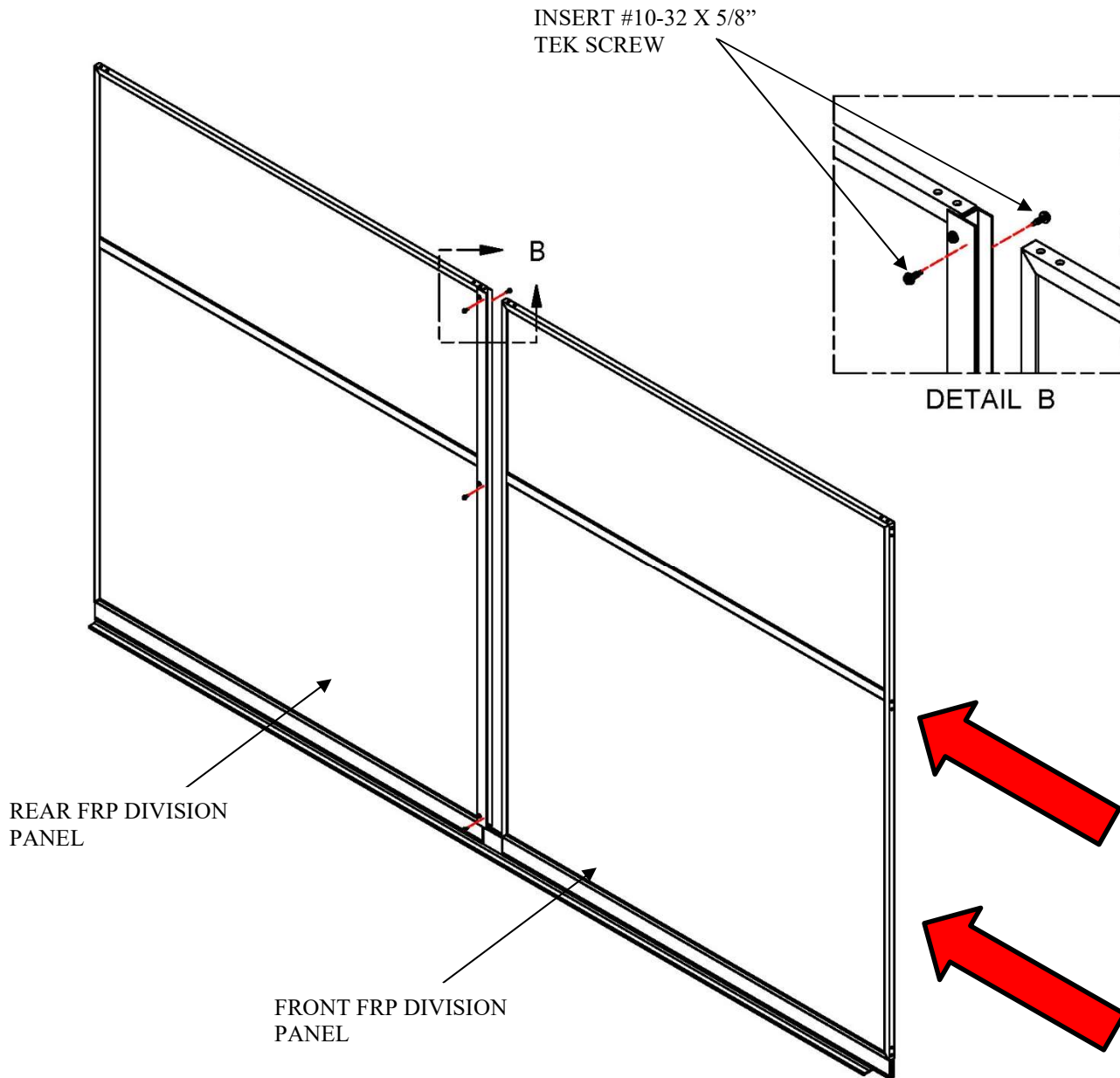

Figure 3B

Section C Run Assembly

- Refer to the floor plan and select a starting point for assembling the runs (preferably on the end of a bank of runs at the intersection of the back panel and outside division panel), which is best

for your application. Once selected, identify the exact location of the outside corner of that run. Mark both sides of the corner on the floor with a chalk line (or other preferred method) as shown in Figure 6. **Important:** Make sure that the two lines are perpendicular and in the exact final location desired for the corner of your kennel.

2. If your system is using Silvis Seals, you must apply them to the Sanislope T's now. Orient the "T" as shown in Figure 4. Apply the end blocker by peeling off the backing strip and positioning the blocker at the end of the "T".

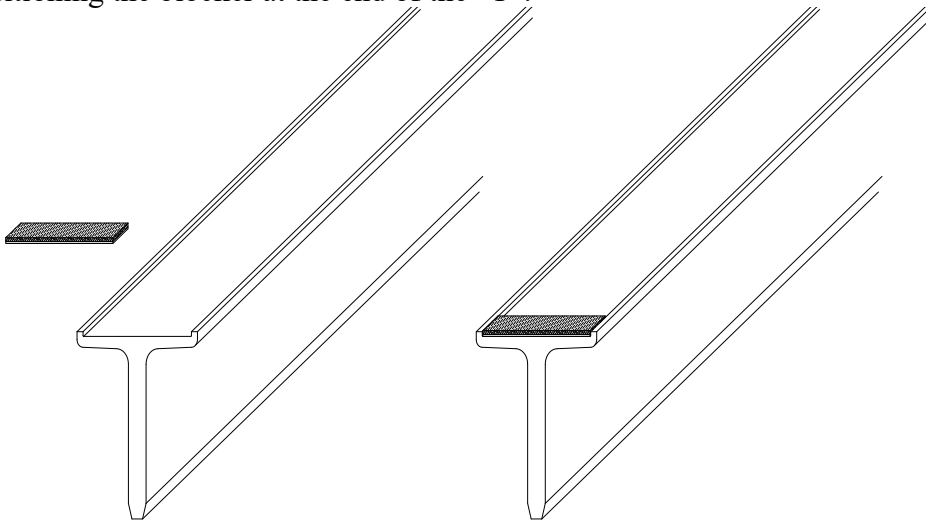

Figure 4

3. Apply the Silvis Seal to the "T" by removing approximately 2 ft. of backing tape. Starting at the end blocker, apply the Seal to the recessed channel in the "T" being careful to orient the Seal in line with the "T". Lay the rest of the Seal in the recessed channel. Carefully pull the remaining backing tape from the "Seal" and using light pressure adhere it to the aluminum as shown in Figure 5.

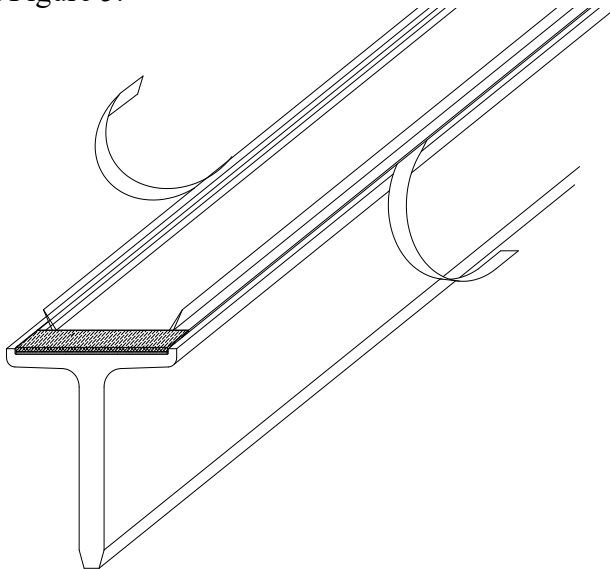

Figure 5

4. Layout the "Sanislope T" sections approximately where they will lie on the final floor plan as shown in Figure 6. **Note: be sure that the end blocker that was installed in step 2 is at the outside or gate end of the run.**
Optional: This system is designed to function equally well whether it is fastened to the floor or not. If you do not want to fasten it the floor skip to Step 6; otherwise proceed with Step 5.

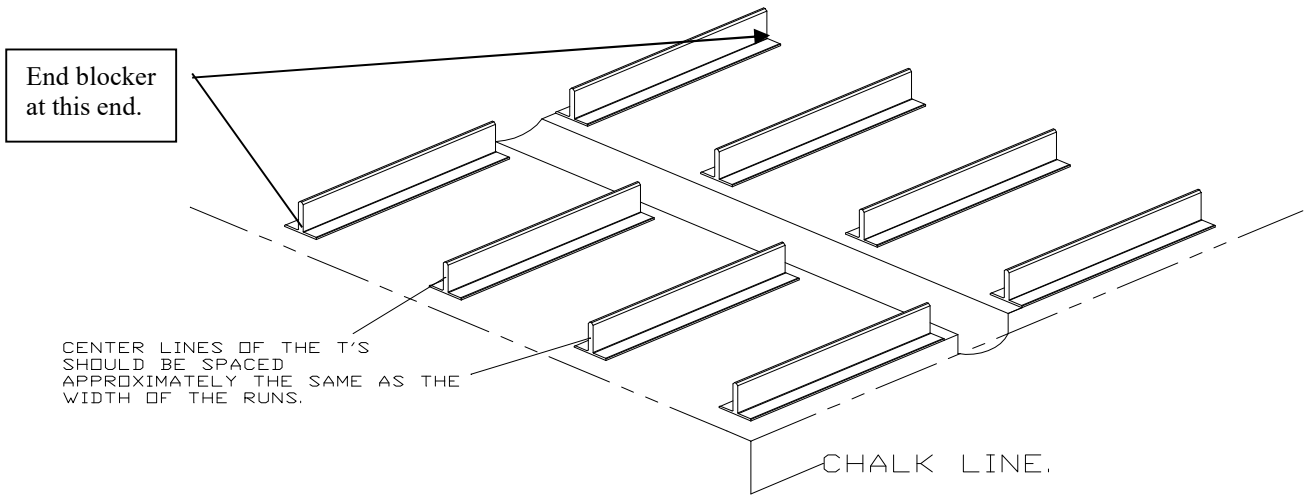

Figure 6

5. Using the 5/16" drill bit, pre-drill the "Sanislope T's" for the outside division panels only, as shown in Figure 23. These holes will be used later to anchor the system to the floor.
6. Install supplied full-length Aluminum Panel Attachment Angle flush with top and back edges of Side Panel. Using the pre-punched holes, install the #10-32 x 5/8" TEK screws provided, apply a screw in every hole. See Figure 7A-B. **These may be preinstalled from the factory in certain cases.**
7. Starting from the point you selected in step C-1 place the first "outside division panel" on the corresponding "Sanislope T". See Figure 7A for the sequence in which to assemble the panels. Orient the first specified "back panel" against the division panel as shown in the exploded view of Figure 7A. **Note:** If your back panels have "Kennel Doors", for appearance sake you may want to locate them all on the same side of the run.

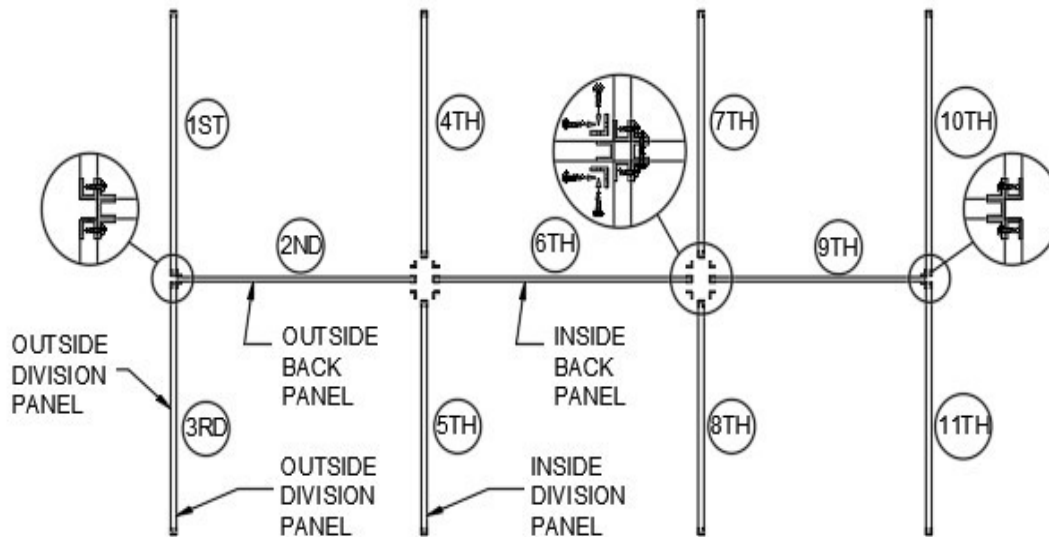

Figure 7A

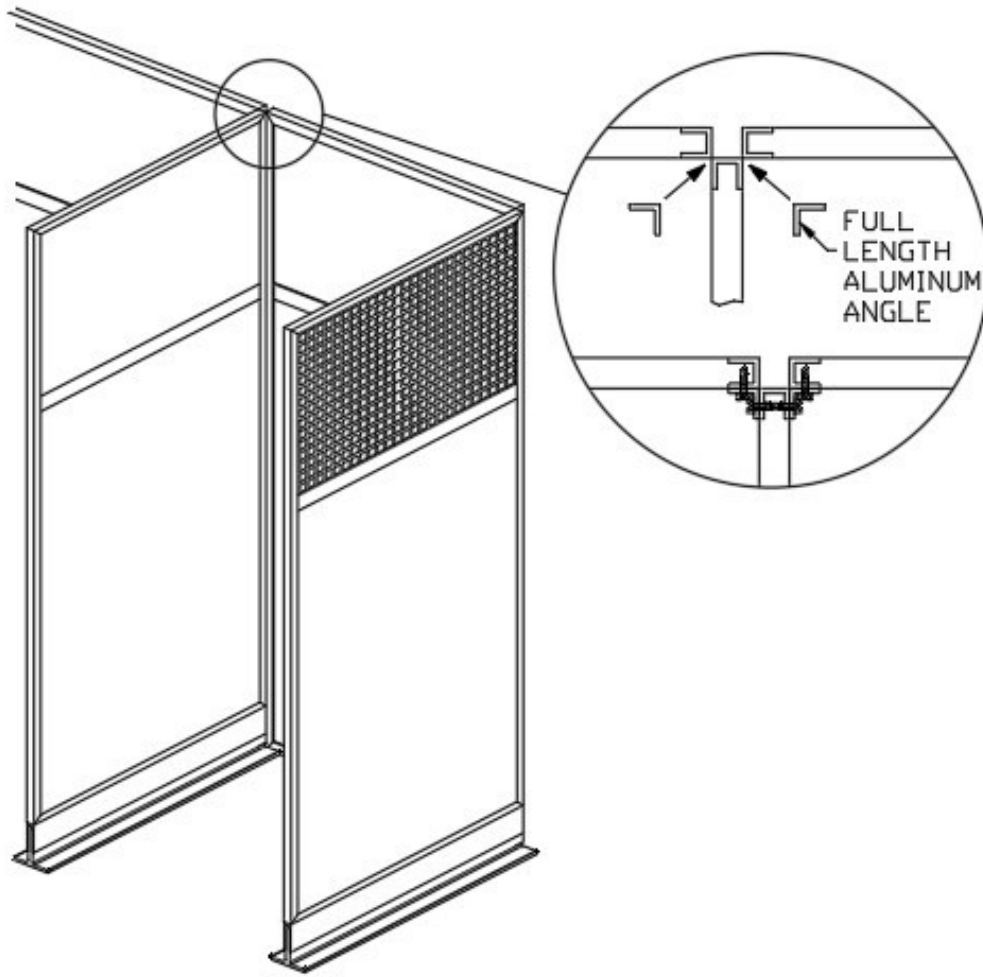

Figure 7B

8. With the tops of the back and division panels aligned and the mating edges of the panels pulled tightly together, as shown in Figure 8, attach the Back Panel to the Division Panel. Connect using the pre-punched holes to install the #10-32 x 5/8" TEK screws provided. Apply a screw in every hole.

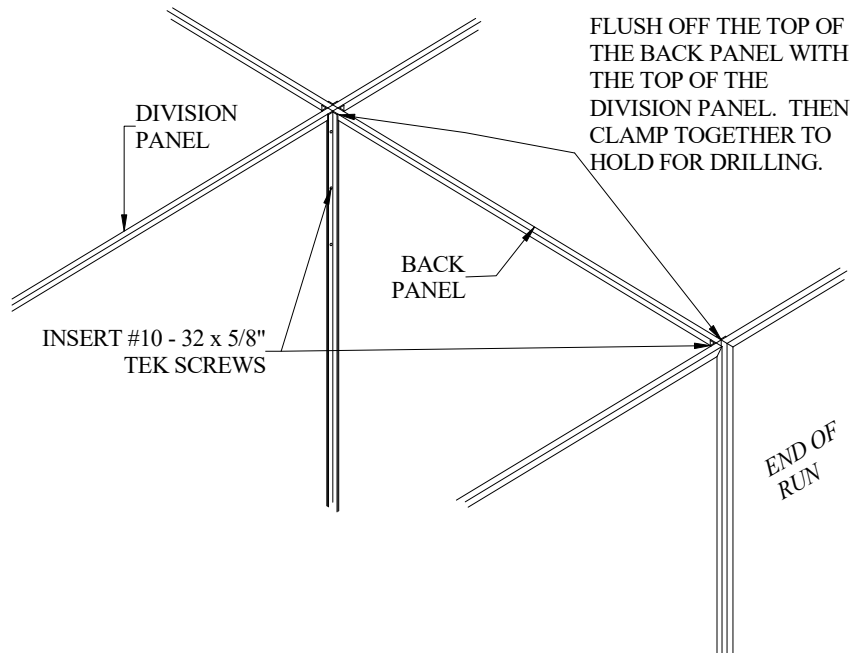

Figure 8

9. Repeat steps C-1 through C-2 to assemble the next division panel to the same back panel in the series opposite of the one just assembled as shown in Figure 7A.
- Note:** If you have sloped floors you will have to raise the panels to ensure that they are aligned and are in contact with each other for the full length of the panel as shown in Figure 9.

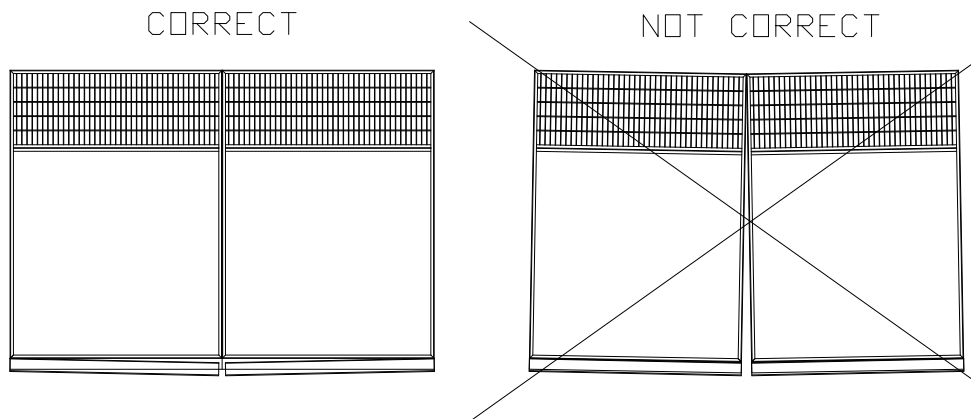

Figure 9

Align the next division panel (4th on Figure 7A) as shown so that the edge of the flange on the division panel lines up with the inside edge of the aluminum frame of the back panel just assembled. With the tops of the two panels aligned and the mating edges of the panels pulled tightly together, as shown in Figure 8, and using the pre-punched holes in the side flange of the back panel as a template, drill an 11/64" hole into the division panel through all holes in the flange. Using the #10-32 x 5/8" TEK screws provided, apply a screw in every hole drilled as you go.

Warning – Do not drill completely through the division panel but only through the first layer of the aluminum channel (1/8" thick).

10. Continue the process until all back panels and remaining division panels of a given bank of runs have been completed. Align and check panels periodically.
11. Repeat Steps B-1 through C-10 for all other banks of runs.

Section D

Leveling the System

1. Using a hammer, tap all the "Sanislope T's" on the front end of the run, back until they are flush with the front edge of the division panel as shown in Figure 10.
2. Holding a level on the top of the first row of outside division panels, carefully pry up the connecting back panel of the first run until the division panels are level. Shim the back panel to hold the division panels level.
3. While the panels remain level, apply downward pressure to the Sanislope T, drill a 11/64" hole at least 1/2" deep, through the "Sanislope H" at the bottom of the division panels into the "Sanislope T", as shown in Figure 10. After each hole is drilled, drive a #10-32 x 5/8" TEK screw into the hole. Spraying a little WD40 into the hole before driving the screws will simplify the process. (**NOTE:** if your system is using the Silvis Seal, it is the downward pressure on the Sanislope Tee that ensures the Silvis Seal performs properly.)
4. Repeat step D-3 for all screw locations shown on Figure 10 for both division panels.

- Repeat steps D-1 through D-3 for all remaining division panels following the same sequence used to assemble the panels as shown in Figure 7A. Continue the leveling process for all runs and or banks of runs.

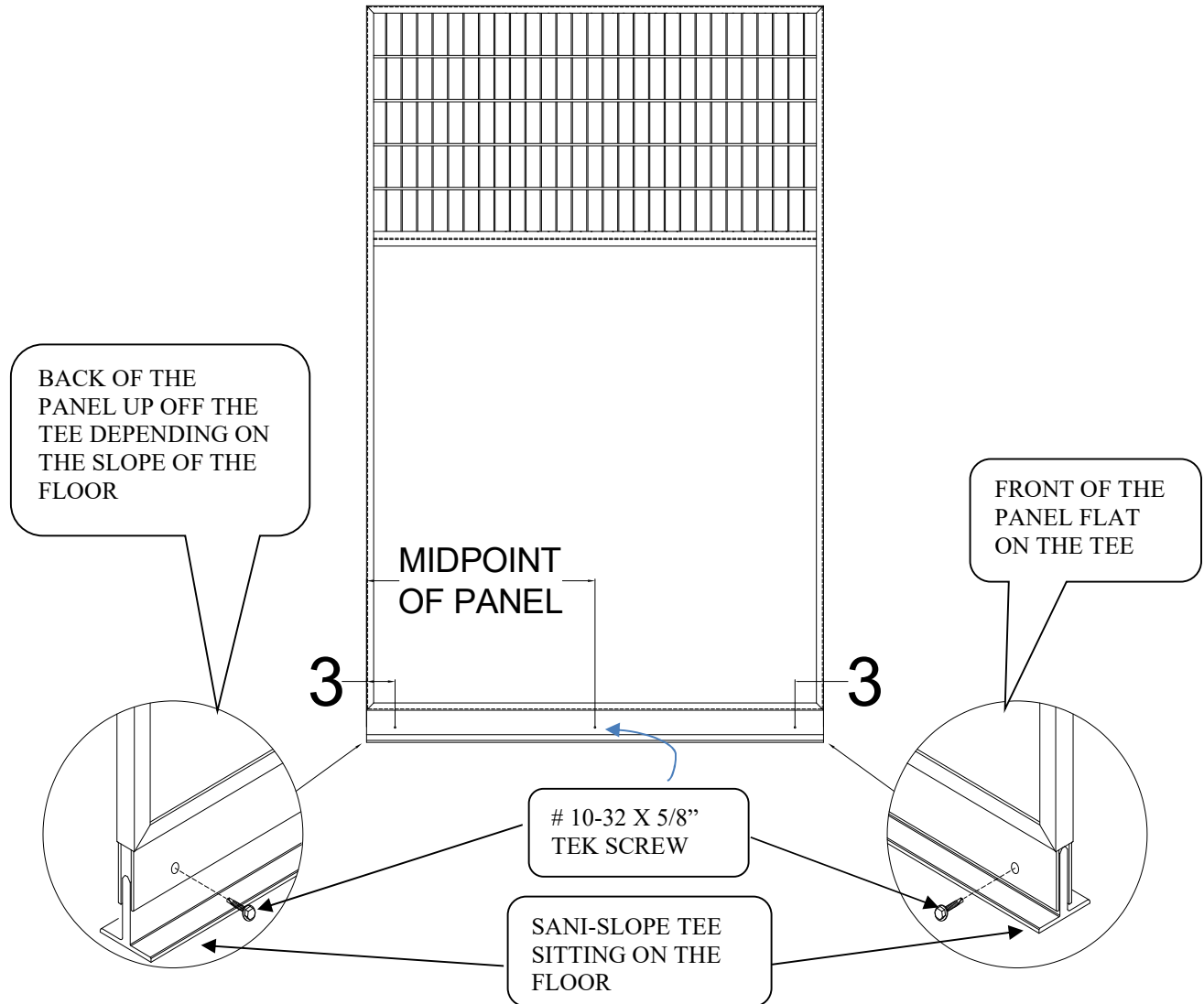

Figure 10

Section E

Gate / Stall Front Hanging

Your system may include chain link or stainless steel gates or stall fronts or both. Use the appropriate instructions for hanging your gates and or stall fronts.

Chain link Gates / Stall Fronts

- Attach the filler pipes to the front end of each division panel with two square-round clamps (it takes two halves to make up one clamp) approximately 6" from either end of the filler pipe using the 5/16" x 1-3/4" carriage bolts and 5/16" nuts provided as shown in Figure 11.

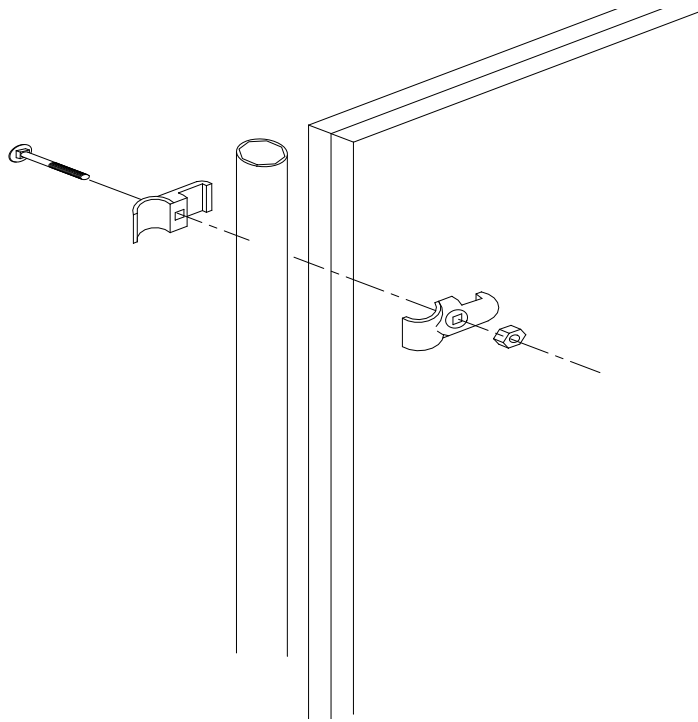

Figure 11

2. Attach the gate/stall front on the front of each run between the filler pipes with two clamps on each side using the 5/16" x 1-1/2" bolts and nuts provided as shown in Figure 12. Note: It takes two halves to make up one clamp. Attach gates / stall fronts to outside division panels using "panel clamps". All other gates/stall fronts will use "triple clamps". **To help ensure the safety of the animals the round head of the bolt should be assembled toward the inside of the run.** Note: The triple clamps attach two gates/stall fronts together. Therefore, you will have to hang two gates/stall fronts at the same time (see Figure 13).
3. Adjust the gate latch following the instructions in section J, "Gate/Stall Front Latch Adjustment".

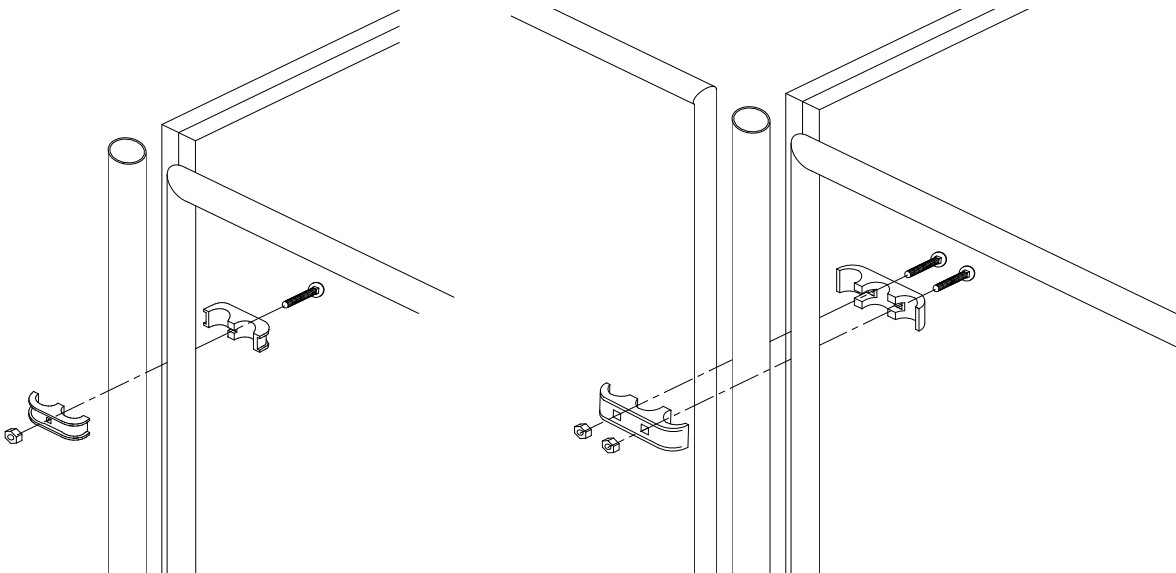

Figure 12

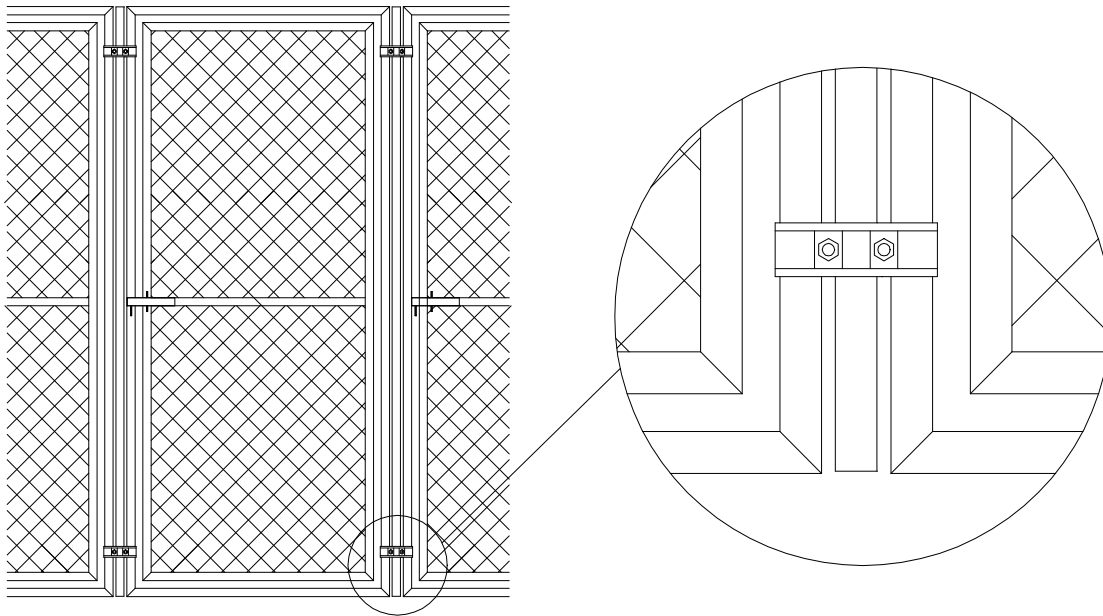

Figure 13

Stainless Steel Gates/Stall Fronts

1. Attach the gate/stall front on the front of each run between the division panels with three clamps on each side using the 5/16” x 1-3/4” bolts and nuts provided as shown in Figure 14. Note: It takes two halves to make up one clamp. Attach gates/stall fronts to outside division panels using “square – 1” panel clamps”. All other gates/stall fronts will use “square – 1” triple clamps”. **To help ensure the safety of the animals the round head of the bolt should be assembled toward the inside of the run.** Note: The triple clamps attach two gates/stall fronts together. Therefore, you will have to hang two gates/stall fronts at the same time (see Figure 15).
2. Adjust the gate latch following the instructions in section J, “Gate/Stall Front Latch Adjustment”.

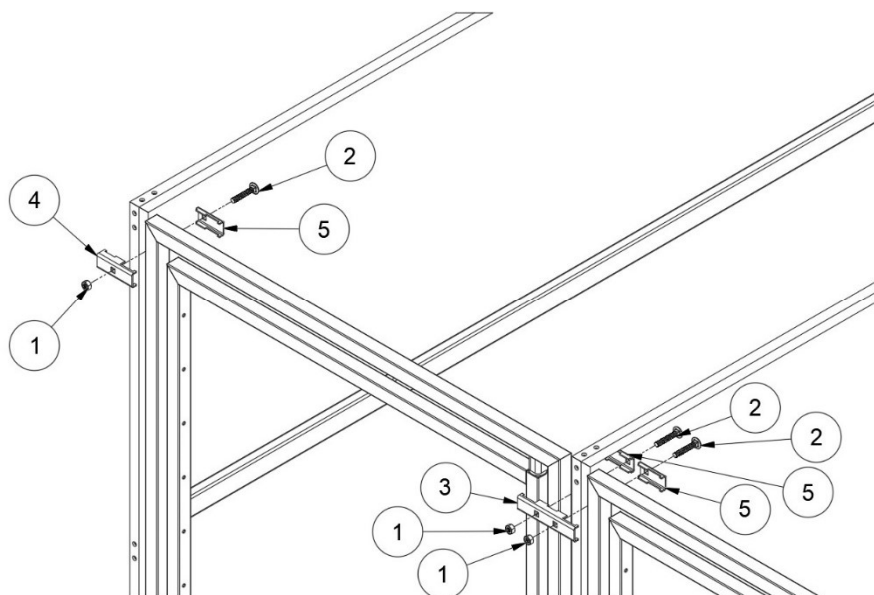

Figure 14

Parts List		
ITEM	PART NUMBER	DESCRIPTION
1	424	5/16-18 SS nut
2	1771	5/16-18 x 1.75" SS carriage bolt
3	8081	1in to 0.75in_Triple Gate Clamp
4	8082	1in to 0.75in_Double Gate Clamp
5	8083	1in to 0.75in_Single Gate Clamp

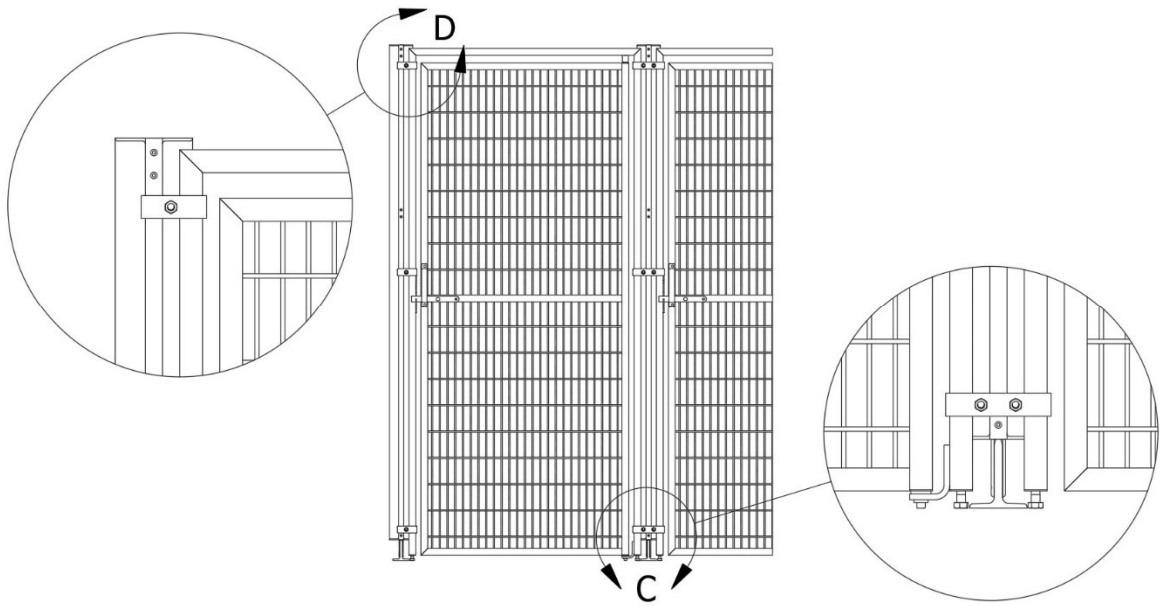

Figure 15

Section F

Gusset Installation

Unless your system is using top covers, you will receive corner gussets and/or overhead bracing to increase the strength and stability of the Sani-Kennel run.

1. Starting in the rear of the kennel, place a gusset against the back and side panel. Align the gusset's upper surface flush with the top of the panels and secure to the aluminum framework using the supplied Tek screws.

Note: If the kennel run is 36" wide or smaller and has a transfer door in the back panel, a small gusset should be used as shown in Figure 17. All other applications will use the large gusset shown in Figure 16.

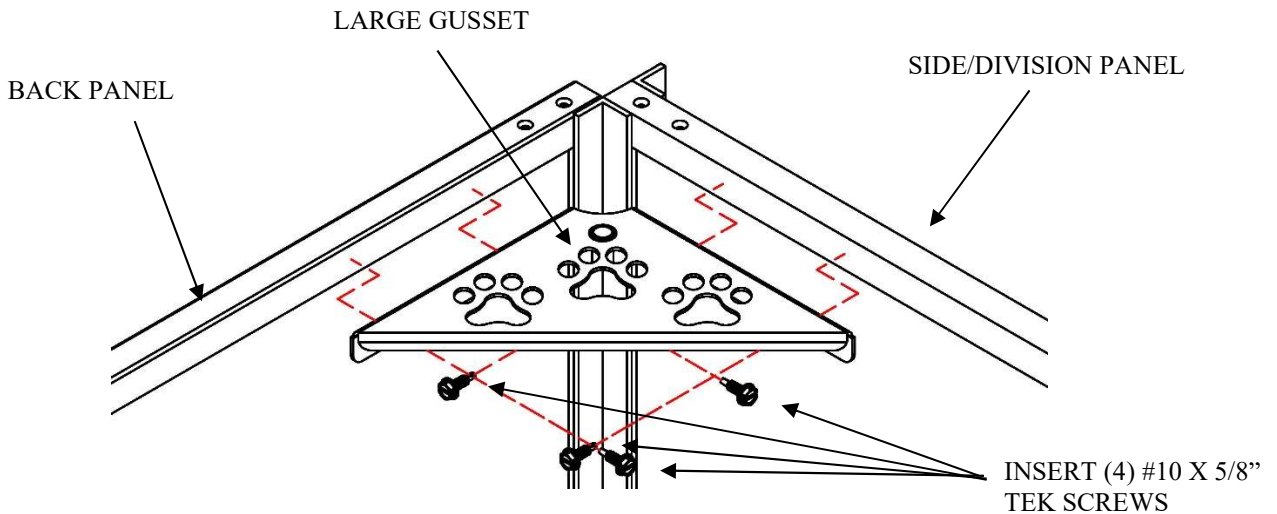

Figure 16

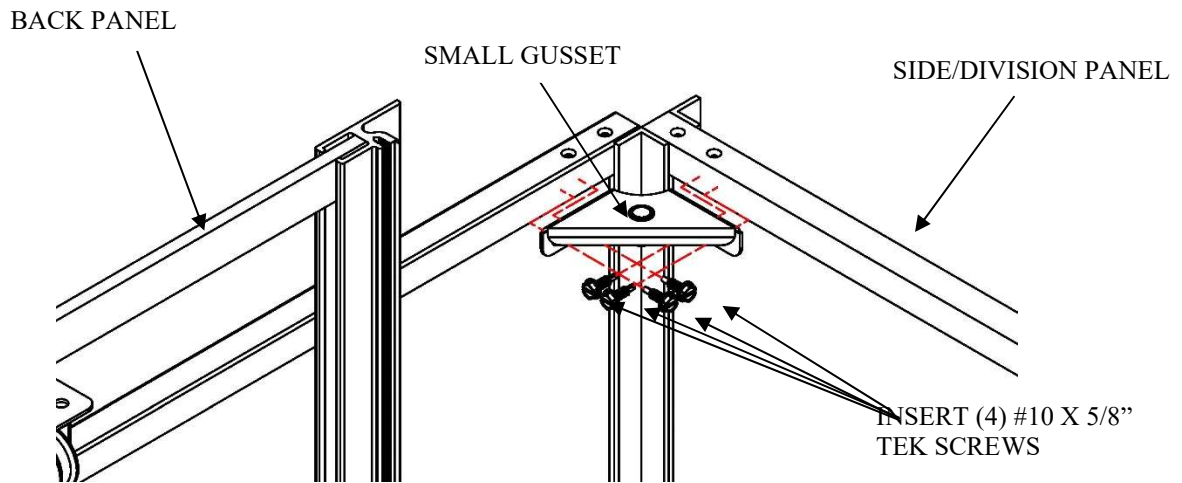

Figure 17

2. Repeat step one for the opposite rear kennel corner.
3. Moving to the front of the kennel, use the previous method and supplied Tek screws to attach a large gusset to the side panel and gate. See Figure 18.

Note: Top surface of gate and side panel should be flush with each other before attaching gusset.

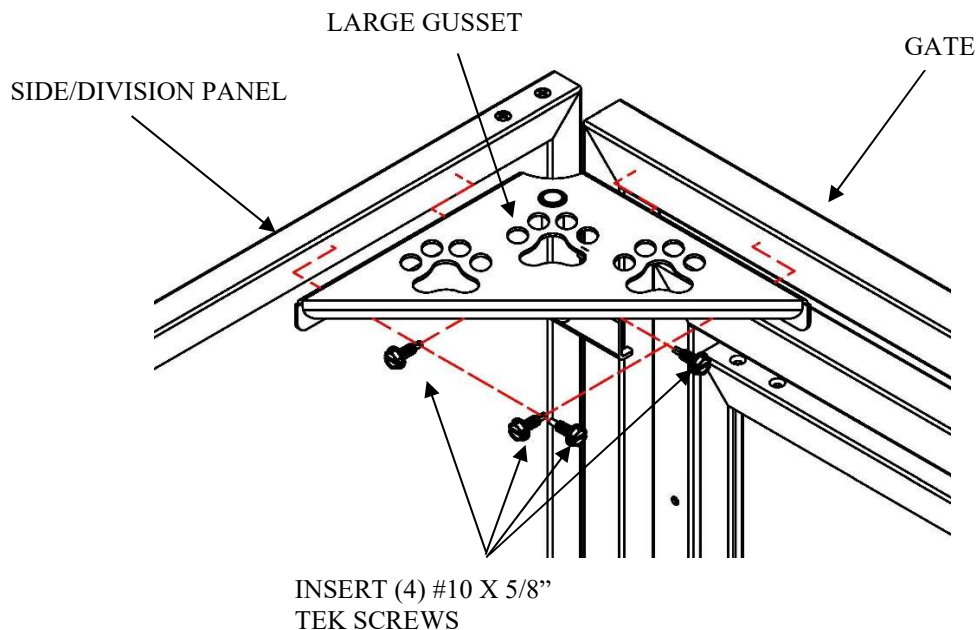

Figure 18

4. Repeat step three for the opposite front kennel corner.
5. For kennels deeper than eight-foot, an additional gusset is required at the side panel connection point. This gusset may or may not be preassembled from the factory. To assemble see Figure 19.

Parts List			
ITEM	QTY	PART NUMBER	DESCRIPTION
1	2	421	1/4-20 Nylock Nut - SS
2	2	933	1/4-20 x 1/2" Truss Head Screw - SS
3	6	2222	#10 x 5/8" Self Drilling Screw - SS
4	1	8415	Long Panel Horizontal Gusset - SS
5	1	8416	Long Panel Vertical Gusset - SS

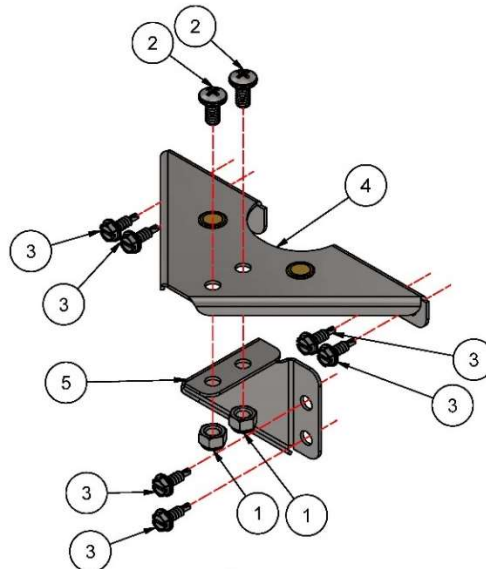

Figure 19

- Once gusset has been assembled, ensure that the top of the gusset and top of the panel are flush. Then, attach gusset to the side panel connection point using the supplied Tek screws, as shown in Figure 20.

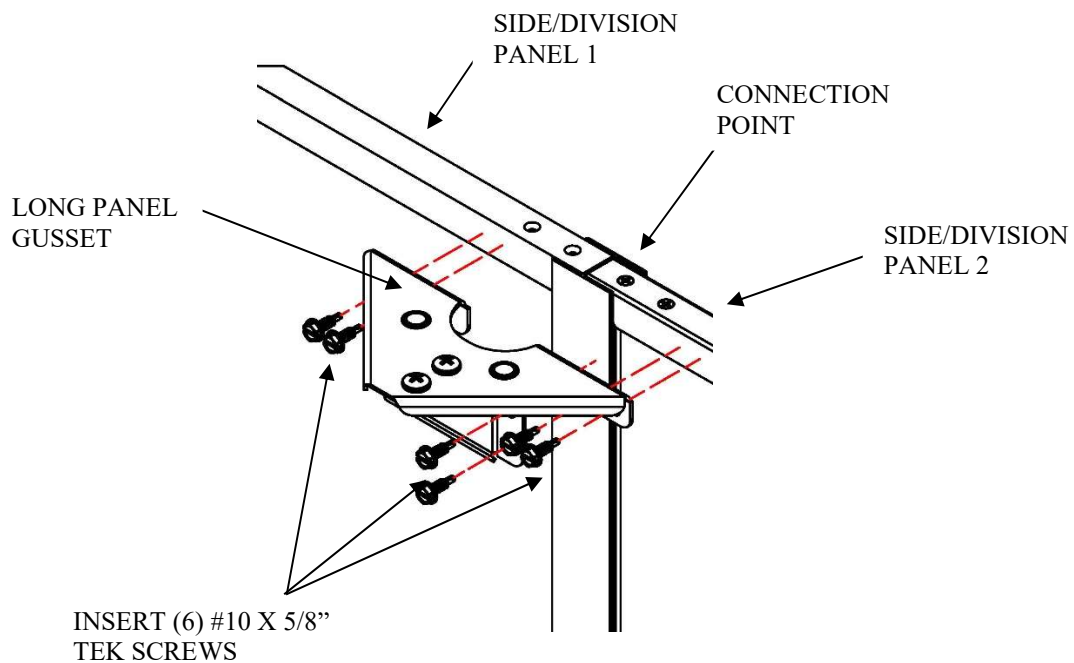

Figure 20

- Repeat step six for the opposite kennel side.

Section G

Overhead Bracing Installation

Some systems may require the use of overhead bracing in addition to the corner gussets to further increase the strength and stability of the Sani-Kennel run. If required, all bracing and mounting hardware will be included.

1. Place overhead brace diagonally on top of the previously installed gussets. The front of the brace should be on the hinge side of the gate as shown in Figure 21.

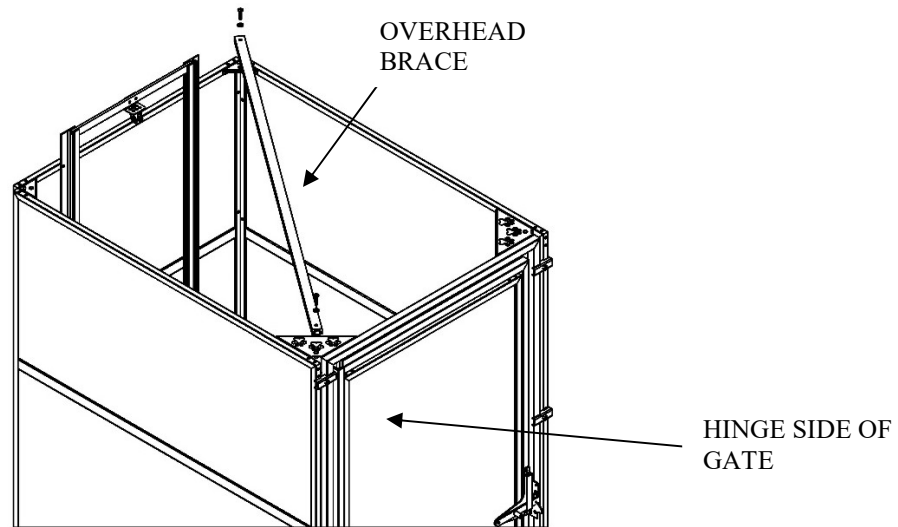

Figure 21

2. Using one of the supplied screws and washer, loosely attach the brace to the threaded insert in the rear gusset. Do not fully tighten!
3. Next, loosely attach the brace to the threaded insert in the front gusset. See Figure 22.

Note: It is unlikely that the front hole in the overhead brace will line up exactly with the threaded insert in the front gusset. Pushing on the side panel where it connects to the hinge side of the gate will allow the holes to line up and will square the system.

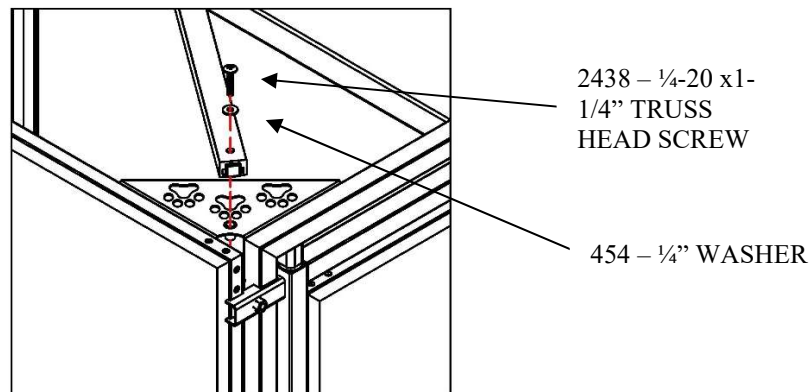

Figure 22

4. Once the system is square, fully tighten the screws attaching the overhead brace.

This Mason system is designed to work equally well whether it is anchored to the floor or not. If you desire to anchor it to your floor proceed with Section H otherwise skip to Section I.

Section H

Anchor System to Floor

Important: Before anchoring your system to the floor verify the entire installation is where you want it, square to the lines marked in step C-1 and leveled. Once you have verified this, you can anchor the “Sanislope T”s on the outside division panels to the floor using the following steps:

1. Using the holes you drilled in step C-3 as a template, drill a 1/4” hole using a hammer drill, with a 1/4” masonry bit to a minimum of 1-1/4” deep.
2. Insert a 1/4” x 1-1/4” Rawl spike (provided) into the hole and drive it in with a hammer until the “Sanislope T” is tight against the floor and the head of the Rawl Spike is tight against the “Sanislope T”.
3. Repeat steps H-1 and H-3 for all hole locations shown in Figure 23.
4. Repeat steps H-1 through H-4 for all outside division panels.

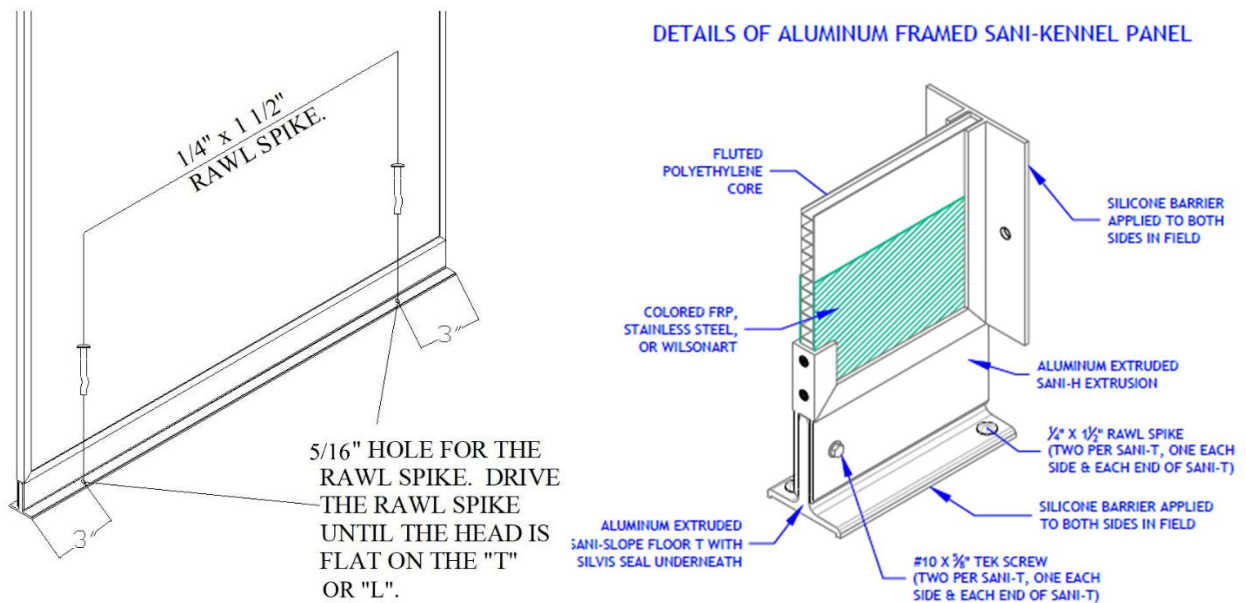

Figure 23

Section I

Sealing

1. Clean along the edge of all the “Sanislope T’s” where they meet the concrete using denatured alcohol applied to a shop rag.
2. Apply a thin bead of sealant provided along the seam created between the “Sanislope T” and the concrete as shown in Figure 23.
3. **If your system is built with Stainless Steel panels you will need to seal the perimeter of the stainless steel on both sides of the panels. Apply a thin bead and wipe away excess with denatured alcohol applied to a shop rag. Refer to Figure 24.**

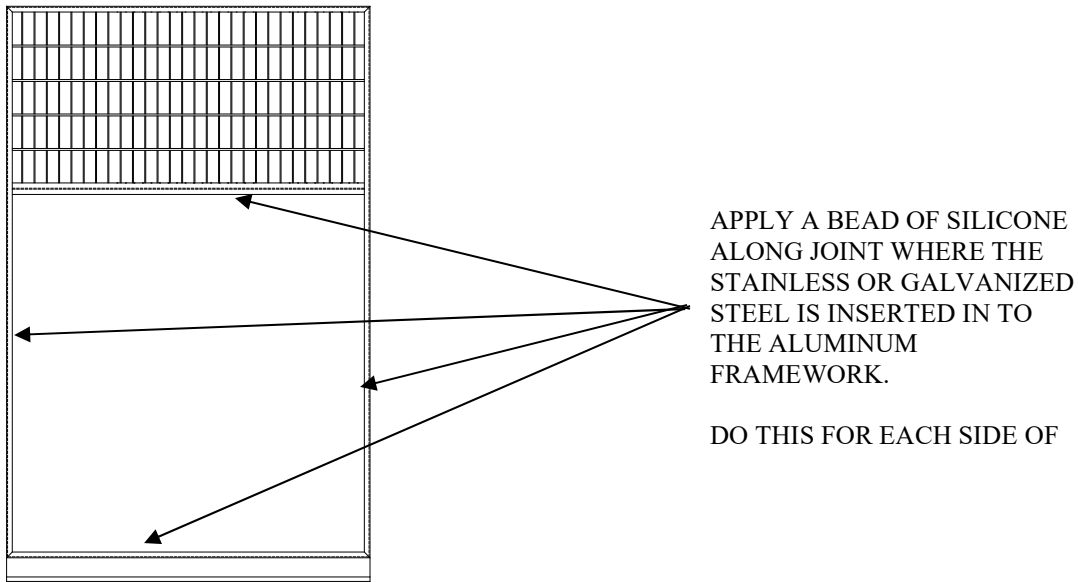

Figure 24

Section J

Gate / Stall Front Adjustment

During shipment and installation, gate assemblies may be forced out of adjustment. If your gate does not latch automatically when pushed closed, the latch can be adjusted by following these instructions.

Chain link Gate / Stall Front (Reference Figure 25)

During the following adjustment process you may need to move the wire mesh slightly. If necessary, use a small block of wood and hammer to tap the wire out of the way.

1. Loosen the latch catch bolt just enough to allow the latch catch to slide up and down.
2. Tap the latch catch up or down until the inside latch bar handle rests on the horizontal brace pipe and the latch bar rests in the bottom of the latch catch.

3. Check to insure the pendant swings freely. If it catches on the latch catch bolt or you've run out of adjustment in the latch catch slot you may have to raise the gate inside of its frame.
4. If the gate needs to be moved, loosen the top and bottom hinge bolts and raise (or lower) both the gate and the top hinge as needed then tighten both hinge bolts.
5. Re-adjust the latch catch.
6. Tighten latch catch bolt.

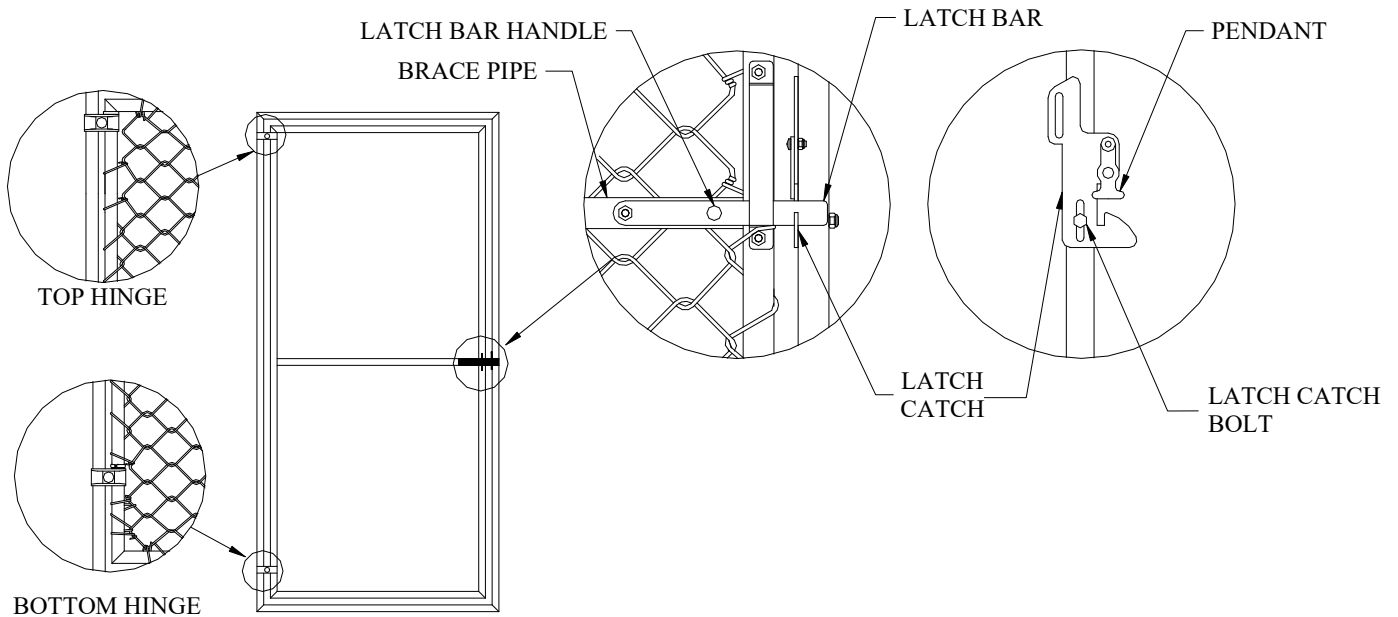

Figure 25

Stainless Steel Gate/Stall Front (Reference Figure 26)

1. Loosen the latch catch bolts just enough to allow the latch catch to slide up and down.
2. Tap the latch catch up or down until the inside latch bar handle rests on the inside of the keeper and the latch bar rests in the bottom of the latch catch.
3. Tighten latch catch bolts.

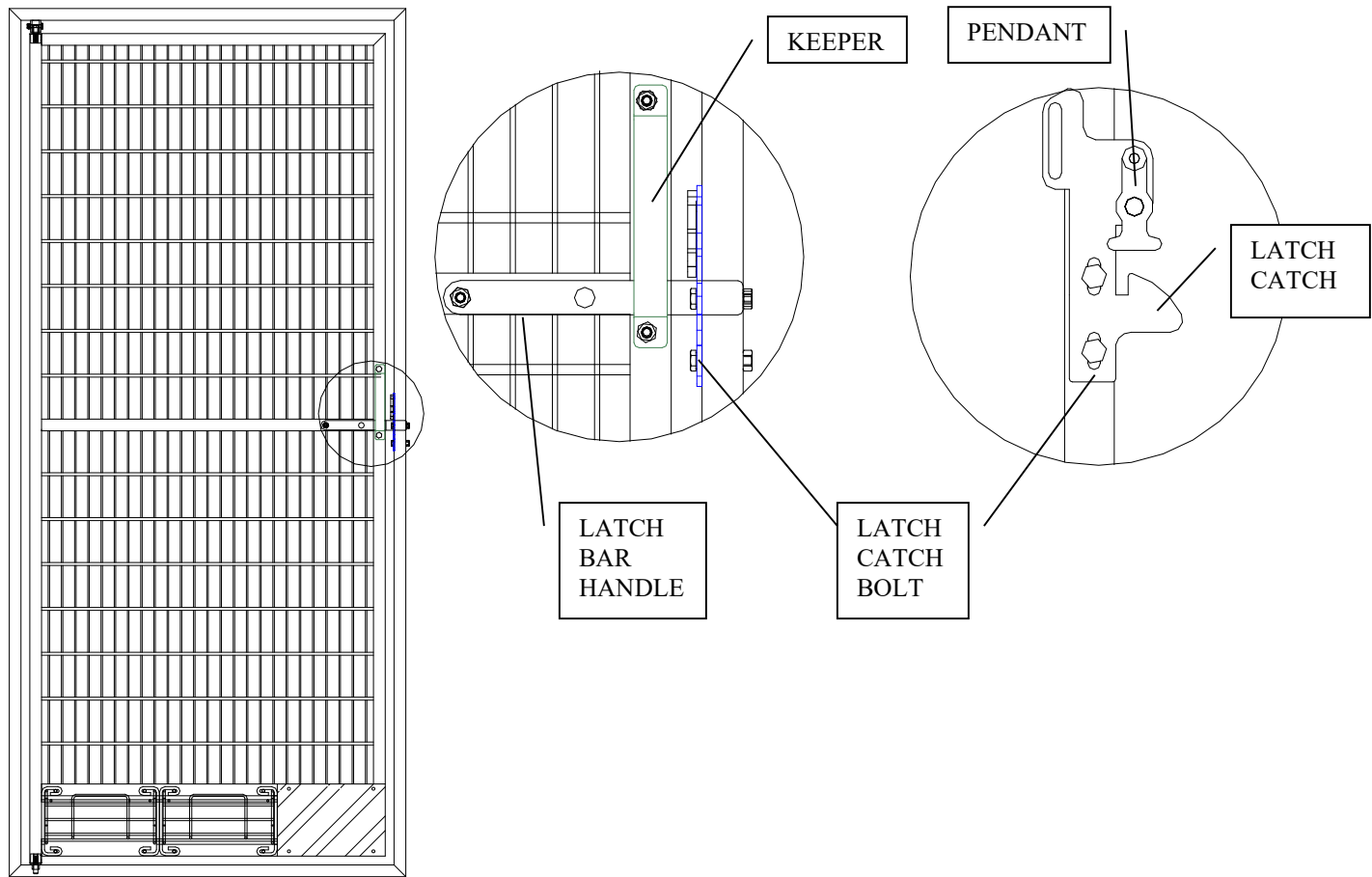
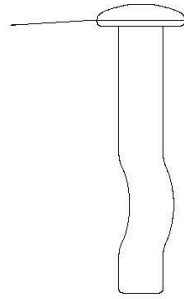

Figure 26

Maintenance

Over time, your Mason kennels might require adjustments, lubrication, or replacement parts remain in top working condition. We recommend a yearly maintenance schedule to lubricate door hinges, adjust gate locks and any other moving parts. A standard, industrial grease works well. If your kennels should need any replacement parts, our professional sales engineers will be happy to review your original order and assist you.

1/4" X 1 1/2"
RAWL SPIKE.
PART # 1400



#12 X 1" SELF TAPPING
SCREW HEX HEAD
PART # 891



5/16-18 NUT
PART # 423

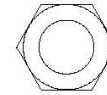

1/4-20 X 1-1/2 HHCS.
PART # 369

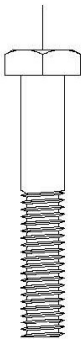

1/4-20 X 1" HHCS.
PART # 366

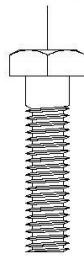

#10 X 32 X 5/8"
HEX WASHER HEAD
TEK SCREW
PART # 2222

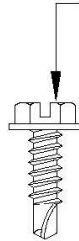

5/16-18 NUT
STAINLESS STEEL
PART # 424

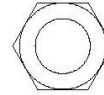

1/4-20 NUT
PART # 422



5/16" X 1-1/2"
GALVANIZED
CARRIAGE BOLT
PART # 356

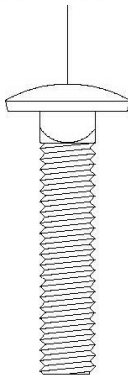

5/16" X 1-3/4"
GALVANIZED
CARRIAGE BOLT
PART # 357

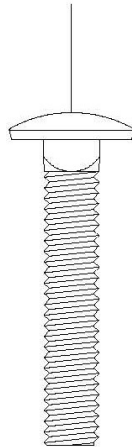

5/16" X 1-1/2"
STAINLESS STEEL
CARRIAGE BOLT
PART # 1955

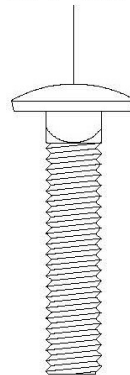

5/16" X 1-3/4"
STAINLESS STEEL
CARRIAGE BOLT
PART # 1771

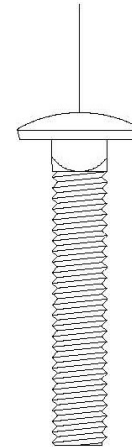

TRIPLE SS CLAMP - 1"
#8081

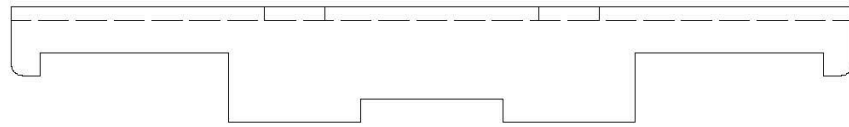

LONG PANEL
VERTICAL GUSSET
#8416



DOUBLE SS CLAMP - 1"
#8082

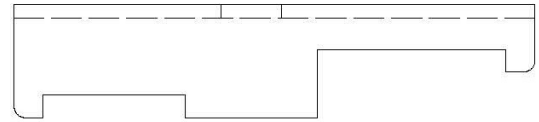

1/4-20 X 1/2"
ROUND HEAD
SCREW
#933



SINGLE SS CLAMP - 1"
#8083

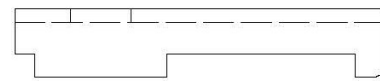

1/4-20 X 1-1/4"
TRUSS HEAD
SCREW
#2438

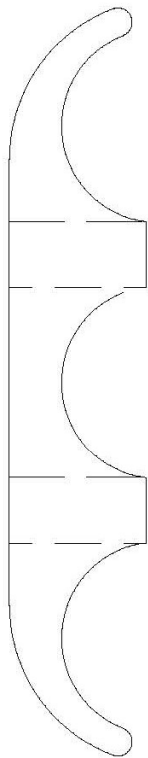

TRIPLE CLAMP
#328



SQUARE TO
ROUND CLAMP
#1468

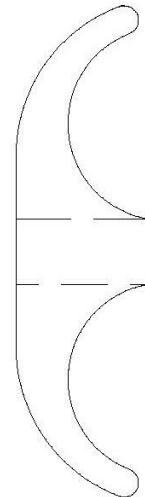

PANEL CLAMP
#330

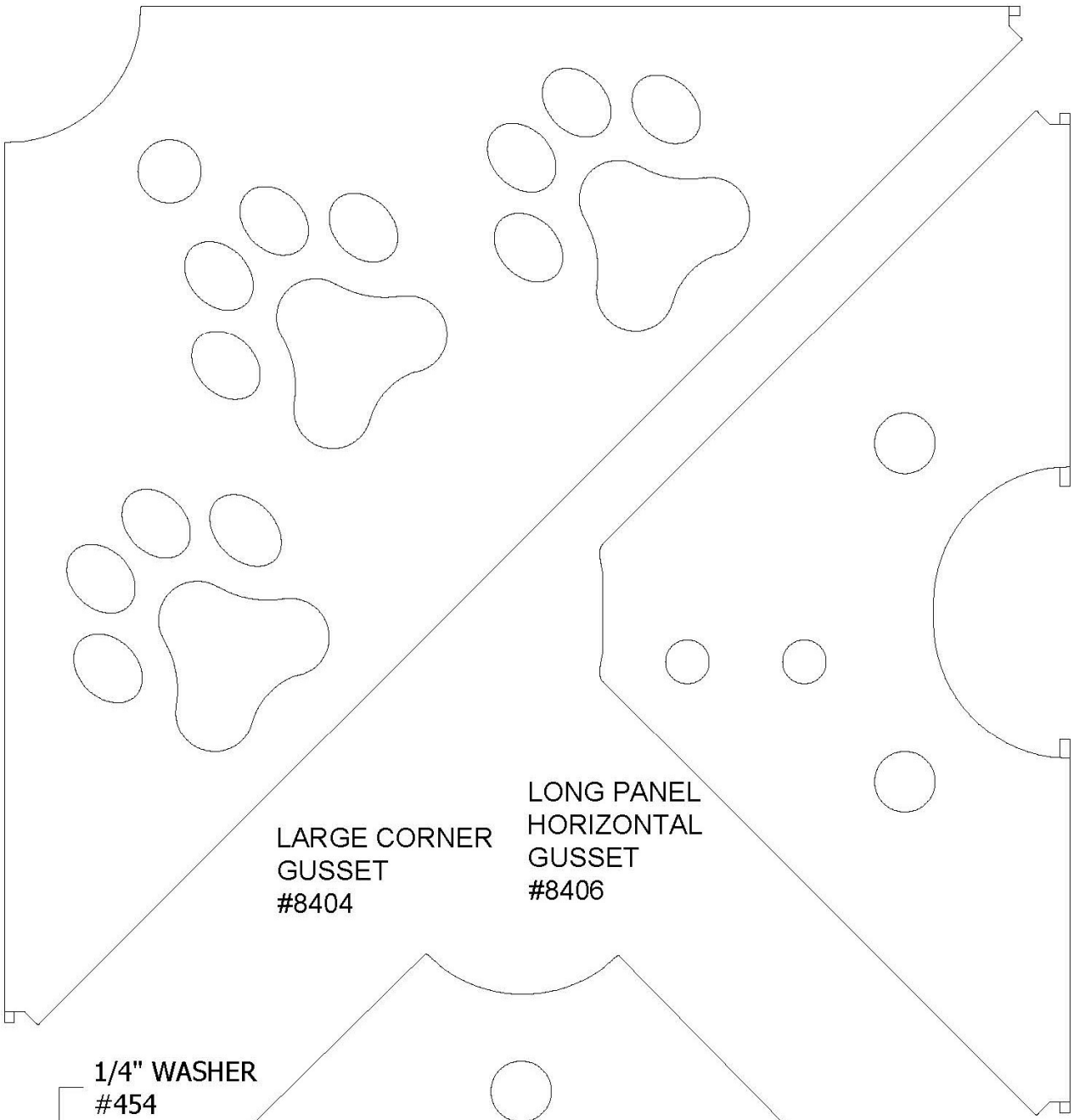

LARGE CORNER
GUSSET
#8404

LONG PANEL
HORIZONTAL
GUSSET
#8406

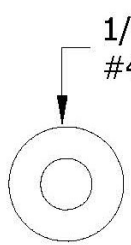

1/4" WASHER
#454

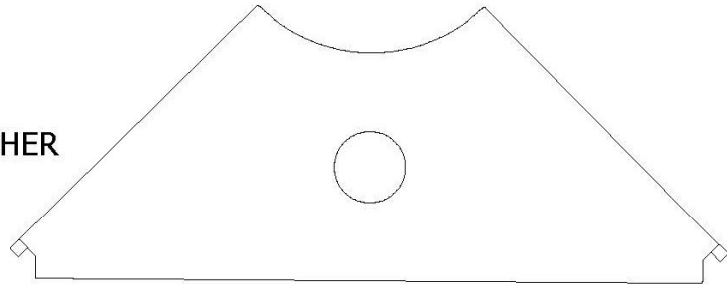

SMALL CORNER
GUSSET
#8405

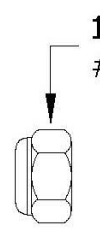

1/4-20 NUT
#421



WALL SHIM
#8406