

Midmark Corporation  
60 Vista Dr.  
Versailles, OH 45380  
1.800.643.6275  
midmark.com

March 27, 2020

Dear Valued Customer,

In the event it is necessary to leave your offices for a length of time exceeding 3 days, we would like to help you observe the necessary steps to properly care for your equipment.

Below are our suggestions for preparing your Sterilizers and Ultrasonic Cleaners for an extended shutdown:

**Caution: Before cleaning, make sure your sterilizer unit is cooled to room temperature.**

#### **Midmark M9™ and Midmark M11™ Sterilizers**

1. Wash the exterior of sterilizer using a cloth or wipe containing a quaternary amine disinfectant. Do not use metal brushes, steel wool or other abrasives to clean the unit. Do not use solutions containing alcohol or bleach.
2. Rinse the sterilizer exterior with water\* and let dry completely.
3. Open the sterilizer door. Clean the gaskets and mating surfaces with a damp cloth.
4. Using the drain tube mounted on the front of the unit, drain the water from the reservoir. With assistance, tilt the unit to ensure the reservoir has been drained as completely as possible. *Note: This step is unnecessary if the sterilizer is connected to a direct-to- drain thermal reduction system.*
5. Remove all trays, racks and plates from the interior of the sterilizer. Wash these items and the inside of the sterilizer chamber with mild soap and water. Rinse with water after washing. \*
6. Let chamber air dry completely before closing the door.

(Reference illustration is provided on page 2)

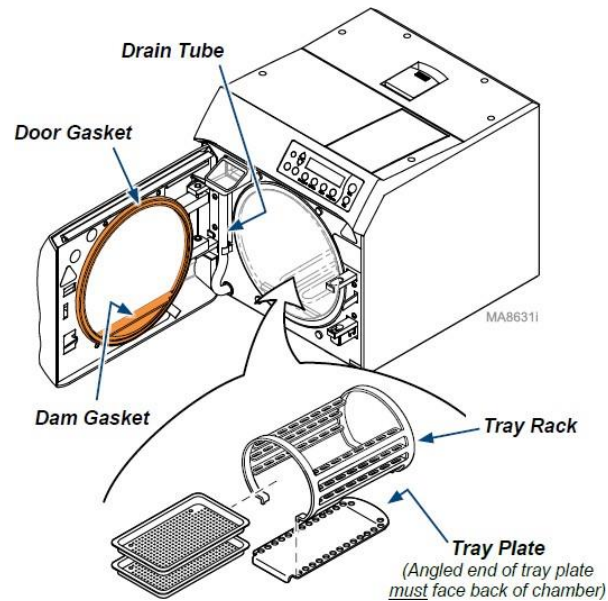

\*Water, when referenced for washing or rinsing, is defined as distilled water or water that meets the water purity specifications found in the User Guide.

### Midmark M3™ Sterilizers

1. Drain water from reservoir.
2. Prime pump for 5-10 seconds by following the following instructions:

#### **To prime the sterilizer pump...**

- A) Put the unit in User Diagnostic Mode.
- B) Press the <START> button to start the pump priming progress.  
The unit will automatically cycle through a pre programmed priming cycle...
  - Closing the sterilizer door.
  - Heating the boiler.
  - Cycling the pump ON and OFF until the pump is primed.
 When finished the 2nd line of the display will show "PRIMING COMPLETE".
- C) Press the <START> button to return to the User Diagnostic Menu.
- D) Turn the power switch OFF (O) to exit User Diagnostic Mode.

3. Put the unit in Service Diagnostics: With the power switch off press and hold the <P> button while turning on the power switch. Release the <P> button when the display reads "SERVICE DIAGNOSTICS".

4. Press the START button to start the I/O Test. With “KEY TEST” shown on the display press the STOP button 4 times. With the display showing “BOILER TEST” press the START button to power on the boiler for 15 seconds to dry the boiler.
5. Wait 30 seconds then turn the power switch OFF to exit the Service Diagnostic Menu.
6. With assistance from co-worker, cautiously tip the unit forward to fully evacuate the reservoir.
7. Remove the door/tray and dry the tray and inside of chamber. Reinsert the door/tray in the chamber.
8. Drain and wipe out external condensing tank.

#### **Midmark M7™ Sterilizers**

1. Drain water from reservoir.
2. With assistance from co-worker, cautiously tip the unit forward to fully evacuate the reservoir.
3. Remove tray rack assembly, wipe down inside of unit, tray rack and trays to be sure all moisture is removed.
4. Close the sterilizer door.

#### **QuickClean® ultrasonic units**

1. Drain water from tank.
2. Wipe down inside of tank and baskets.

Please call our technical support team if you have questions.

Designing better care.™

Midmark Technical Support  
1.800.643.6275