

Installation Manual

354 Lighting System

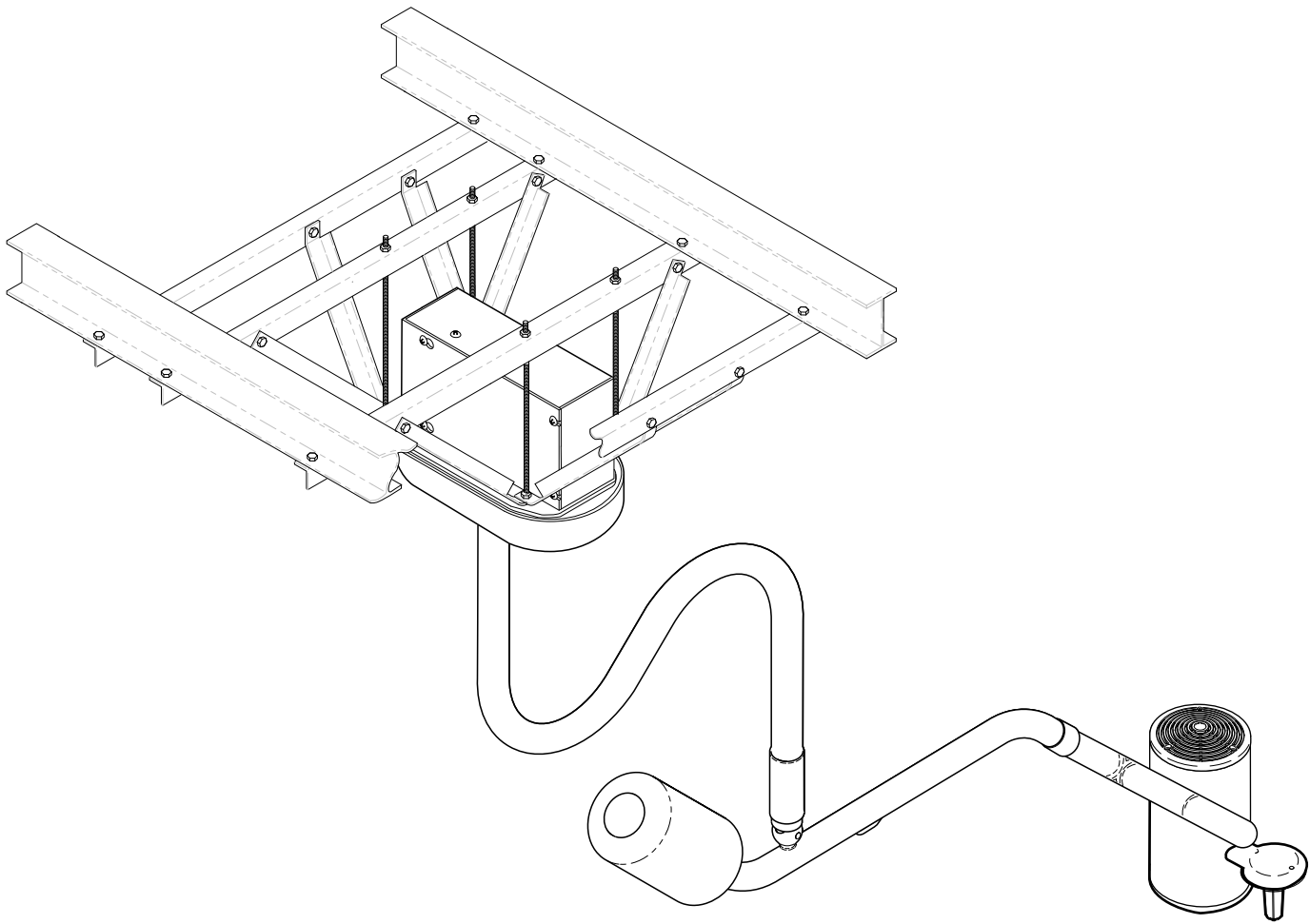

MA551803

Owner's Product Identification

(information that you will need to provide for servicing - key information is highlighted)

Date of Purchase

Serial Number

Name of Owner / Facility / Department

Model Number

Name of Authorized Dealer

Telephone # of Authorized Dealer

Address of Authorized Dealer

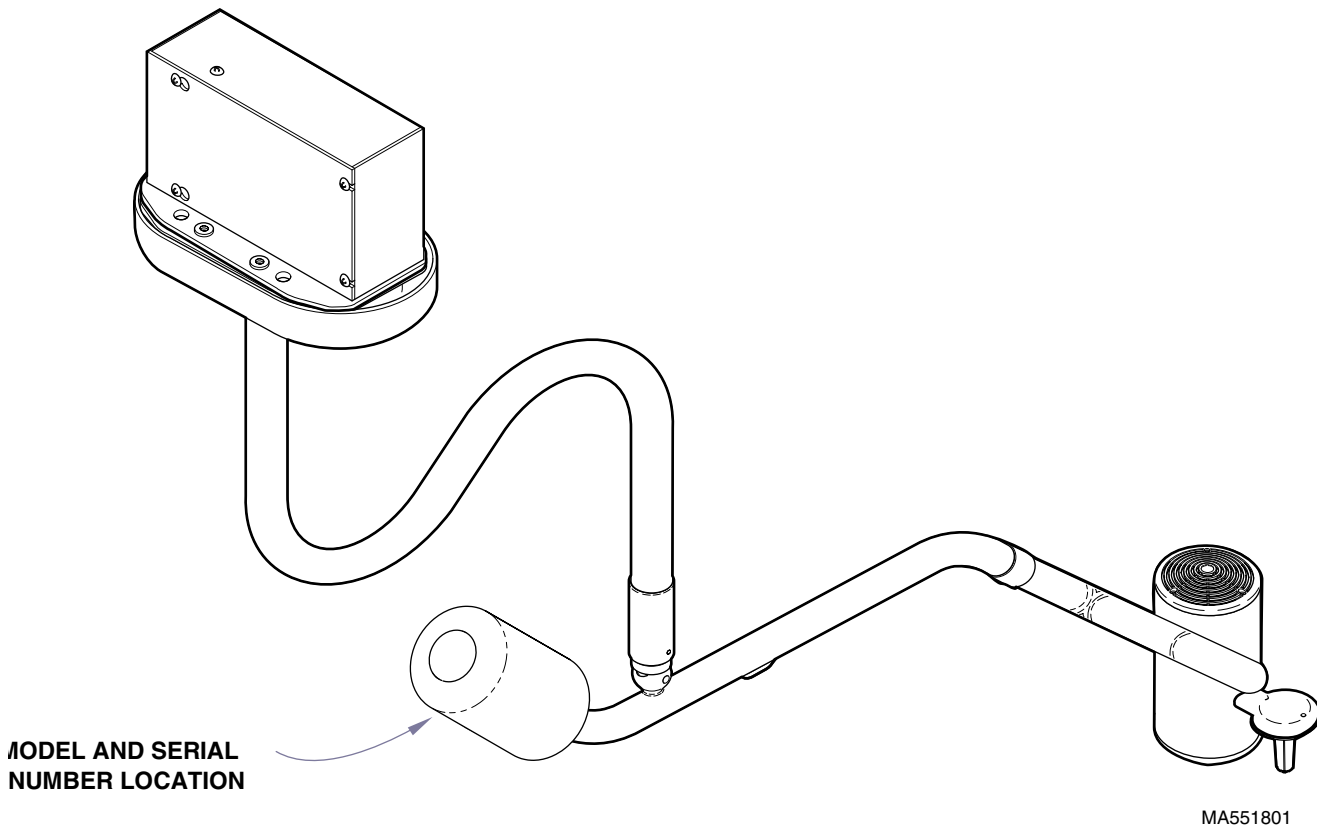

Figure 1. Model Number / Serial Number Location

CONTENTS

| | |
|--|-----------|
| IMPORTANT INFORMATION..... | 2 |
| Scope and Purpose of this Manual..... | 2 |
| Intended Use of Product..... | 2 |
| Safety Instructions..... | 2 |
| Explanation of Safety Symbols and Notes..... | 2 |
| Transportation and Storage Conditions..... | 3 |
| GENERAL INFORMATION..... | 3 |
| Lighting System..... | 3 |
| Specifications..... | 3 |
| 354 LIGHTING SYSTEM INSTALLATION..... | 4 |
| Unpacking..... | 4 |
| Recommended Ceiling Mounting Locations (For Dental and Medical Applications)..... | 5 |
| Ceiling Support Structure Installation..... | 5 |
| Electromagnetic Interference..... | 6 |
| Wiring Installation..... | 7 |
| Junction Box Wiring Connections..... | 7 |
| Ceiling Plate Assembly Installation..... | 9 |
| Down Tube Installation..... | 11 |
| Cross Tube Assembly Installation..... | 12 |
| Housing Cap Installation..... | 13 |
| Operational Test..... | 13 |
| TROUBLESHOOTING..... | 13 |
| Troubleshooting Guide..... | 13 |
| ADJUSTMENTS..... | 16 |
| Ball Pivot Tension Adjustment..... | 16 |
| Cross Tube Counterbalance Adjustment..... | 16 |
| CALLING FOR SERVICE..... | 17 |
| LIMITED WARRANTY..... | 18 |

IMPORTANT INFORMATION

SCOPE AND PURPOSE OF THIS MANUAL

This manual covers complete instructions for the installation of the 354 Lighting System and is intended to be used by personnel involved in the installation of the 354 Lighting System. The Operation Manual (Part Number: 003-1071-xx) for the 354 Lighting System is a separate document and is intended for persons who will operate the 354 Lighting System.

INTENDED USE OF PRODUCT

This product is intended for use in all medical environments where illumination is required for external examinations and procedures.

SAFETY INSTRUCTIONS

The primary concern of Midmark is that this equipment be operated and maintained with the safety of the users in mind. To assure safer and more reliable operation, do the following: (1) Read this manual before installing your light assembly; (2) Assure that appropriate personnel are informed on the contents of this manual--this is the responsibility of the purchaser; (3) Be sure that you understand the instructions contained in this manual before attempting to install this light assembly; (4) Be sure that you have read and understand the instructions contained in the Operation Manual (a separate document) before attempting to operate this equipment.

EXPLANATION OF SAFETY SYMBOLS AND NOTES

Throughout this manual are safety alert symbols that call attention to particular procedures. These items are

used as follows:



DANGER

A **DANGER** is used for an imminently hazardous operating procedure, practice, or condition which, if not correctly followed, will result in loss of life or serious personal injury.



WARNING

A **WARNING** is used for a potentially hazardous operating procedure, practice, or condition which, if not correctly followed, could result in loss of life or serious personal injury.



CAUTION

A **CAUTION** is used for a potentially hazardous operating procedure, practice, or condition which, if not correctly followed, could result in minor or moderate injury. It may also be used to alert against unsafe practices.



EQUIPMENT ALERT

An **EQUIPMENT ALERT** is used for an imminently or potentially hazardous operating procedure, practice, or condition which, if not correctly followed, will or could result in serious, moderate, or minor damage to unit.

NOTE

A **NOTE** is used to amplify an operating procedure, practice or condition.



Indicates that the unit is rated: Type B, Applied Part.



Indicates that the operator's manual should be consulted for important information.



Indicates the presence of a dangerous voltage / shock hazard.



Indicates a fuse rating specification



Indicates a protective earth ground.



Indicates that the product is fragile; do not handle roughly.



Indicates the proper shipping orientation for the product.



Indicates that the product must be kept dry.



Indicates a hot surface.

TRANSPORTATION AND STORAGE CONDITIONS

- Ambient Temperature Range: ... -22°F to 140°F (-30°C to +60°C)
- Relative Humidity 10% to 90% (non-condensing)
- Atmospheric Pressure 500hPa to 1060hPa (0.5 bar to 1.06 bars)

This product contains glass, so it should be transported and stored with care to limit vibrations and shocks.

GENERAL INFORMATION

LIGHTING SYSTEM

The 354 lighthead assembly is a compact spotlight. The spotlight design provides excellent control over the diameter of the lighted area. Through the movement of two levers, the user has complete control over the light beam diameter between 3 in. (7.6 cm) to 10 in. (25.4 cm) and over the brightness of the lighted area. The peak illumination is 4,000 fc (43,000 lux) at a distance of 36 in. (91.4 cm). The plastic handle can be easily removed for sterilization or it accepts a Devon EZ Handle™ without requiring an awkward adapter. The arm assembly has been precisely designed, assembled, and balanced so that the lighthead can be positioned with minimal force and no drifting will occur. In addition, multiple pivot points make the positioning of the lighthead easy and flexible.

SPECIFICATIONS

See Table 1 for specifications on the 354 Lighting System.

Model 354 Light

- Beam diameter @ 36 in. (91.4 cm.):** Variable from 3 to 10 in. (7.6 to 25.4 cm)
- Bulb:** 21.0 VAC, 150 W halogen bulb
- Color temperature:** 4,200K
- Focal length:** 36 in. (91.4 cm)
- Illumination @ 36 in. (91.4 cm):** 4,000 fc (43,000 lux)
- Electrical requirement:** 120 VAC, 60 HZ
1.5 amps, single phase
- Reach of arm assemblies:** ... 49.5 in. (126 cm) maximum from centerline of down tube to center of lighthead.

- Rotation of Lighthead:** 180° rotation at lamp tube connection
- Rotation of lamp tube:** 540° rotation at cross tube connection
- Rotation of cross tube:** 580° rotation at down tube connection
- Vertical range of cross tube:** -35° to +35° vertical movement
- Rotation of down tube:** 580° rotation at ceiling plate connection
- Weight of 8 ft. (2.44 m) single light assembly:** 59 lbs (26.8 kg)
- Weight of 9 ft. (2.74 m) single light assembly:** 60 lbs (27.2 kg)
- Weight of 8 ft. (2.44 m) dual light assembly:** 105 lbs (47.6 kg)
- Weight of 9 ft. (2.74 m) dual light assembly:** 107 (48.5 kg)

Certifications:  Classified by

Underwriters Laboratories Inc. with respect to electric shock, fire, and mechanical hazards only in accordance with UL2601-1 and CAN/CSA C22.2, No.601.1.

ISO-9001 Certified

Classifications: Class 1, Type B applied part, Ordinary Equipment, Continuous Operation

Fuse Rating: 1.6 amp, 250 VAC, 5mm x 20mm, Type T, low breaking capacity, IEC 127-2/3

Equipment not suitable for use in the presence of a flammable anesthetic mixture with air, oxygen, or nitrous oxide.

354 LIGHTING SYSTEM INSTALLATION

UNPACKING

NOTE
Below is a list of all the items which should be included in the shipping box(es). The first quantity indicates the number of items which should be present for a single lighting assembly while the second quantity indicates the number of items which should be present for a dual lighting assembly (Refer to Figure 2).

(1) Cut banding and remove box lid from box.

- (2) Remove one / two cross tube/lighthouse assembly (1, Figure 2) and inspect.
- (3) Remove one/two down tube assembly (2) and inspect.
- (4) Remove one/two bag(s) (3) and inventory contents; the following items should be included:
 - 3a. Four #10-24 x 3/4" socket cap screws
 - 3b. Two/four #10-24 x 3/8" black oxide button head screws
 - 3c. Six/twelve 3/8"-16 hex nuts
 - 3d. Three/six 3/8" lockwashers
 - 3e. One/two housing cap
 - 3f. One/two #10-24 x 5/8" zinc plated button head screws
 - 3g. One/two #10-24 x 3/8" pan head screws
 - 3h. One 100 Watt Halogen Bulb
 - 3i. One/two sterilizable handle (inspect)

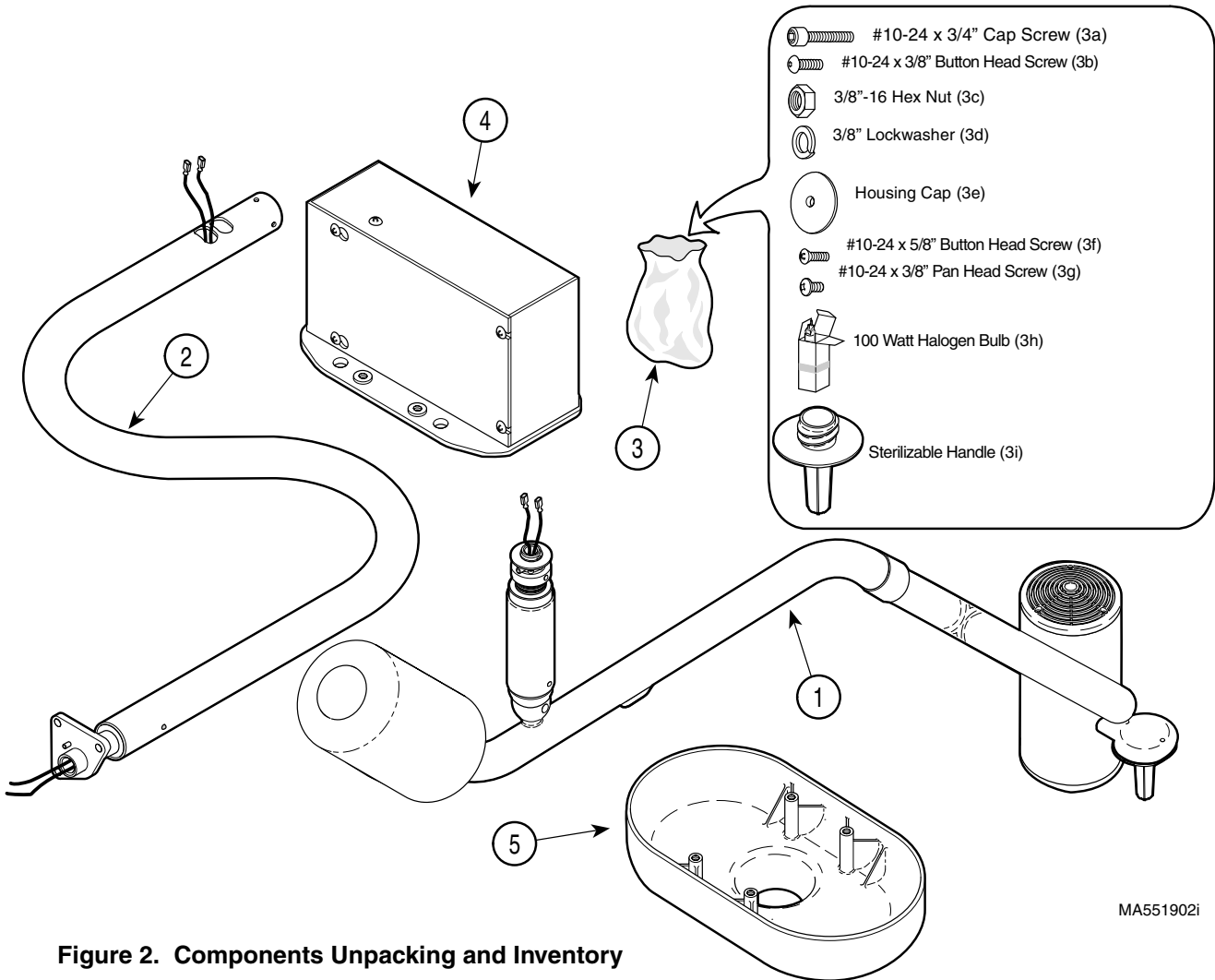

Figure 2. Components Unpacking and Inventory

MA551902i

- (5) Remove one ceiling plate assembly (4) and inspect.
- (6) Remove one ceiling cover (5) and inspect.

RECOMMENDED CEILING MOUNTING LOCATIONS (FOR DENTAL AND MEDICAL APPLICATIONS)

See Figure 3 for recommended ceiling mounting locations. These locations allow the lighthead to be positioned over any portion of the patients body without running into a physical arm restriction; mounting the light system on the centerline of the chair or headrest will result in some areas of the patient’s body not being able to be illuminated by the lighthead. Also, the light system should be mounted on the opposite side of the table as the doctor’s work position, so the light system is not hanging above their head.

NOTE
When installing ceiling plate it is recommended to leave adequate distance to access and remove junction box cover

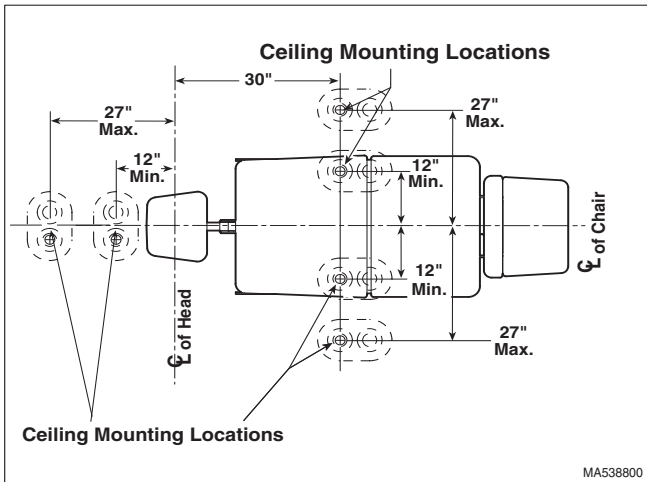

Figure 3. Recommended Ceiling Mounting Locations (For Dental and Medical Applications)

CEILING SUPPORT STRUCTURE INSTALLATION

Weights:

- 8 ft. (2.44 m) Single 354 Lighting System (less customer supplied ceiling structure):..... 59 lbs (26.8 kgs)
- 9 ft. (2.74 m) Single 354 Lighting System (less customer supplied ceiling structure):..... 60 lbs (27.2 kgs)
- 8 ft. (2.44 m) Dual 354 Lighting System (less customer supplied ceiling structure):..... 105 lbs (47.6 kgs)
- 9 ft. (2.74 m) Dual 354 Lighting System (less customer supplied ceiling structure):..... 107 lbs (48.5 kgs)

Torques:

- 8 ft. (2.44 m) Single 354 Lighting System:69 ft-lbs (94 N•m)
- 9 ft. (2.74 m) Single 354 Lighting System:69 ft-lbs (94 N•m)
- 8 ft. (2.44 m) Dual 354 Lighting System:136 ft-lbs (184 N•m)
- 9 ft. (2.74 m) Dual 354 Lighting System:137 ft-lbs (186 N•m)

NOTE
The illustrations in Figure 4 are for suggestion only. Midmark does not supply ceiling structures. Consult a structural engineer for the best solution for your situation.

The 354 lighting system requires a sturdy ceiling support structure to support the weight and the dynamic torque which will be applied to the support structure (See Figure 4)

CEILING PLATE LAYOUT

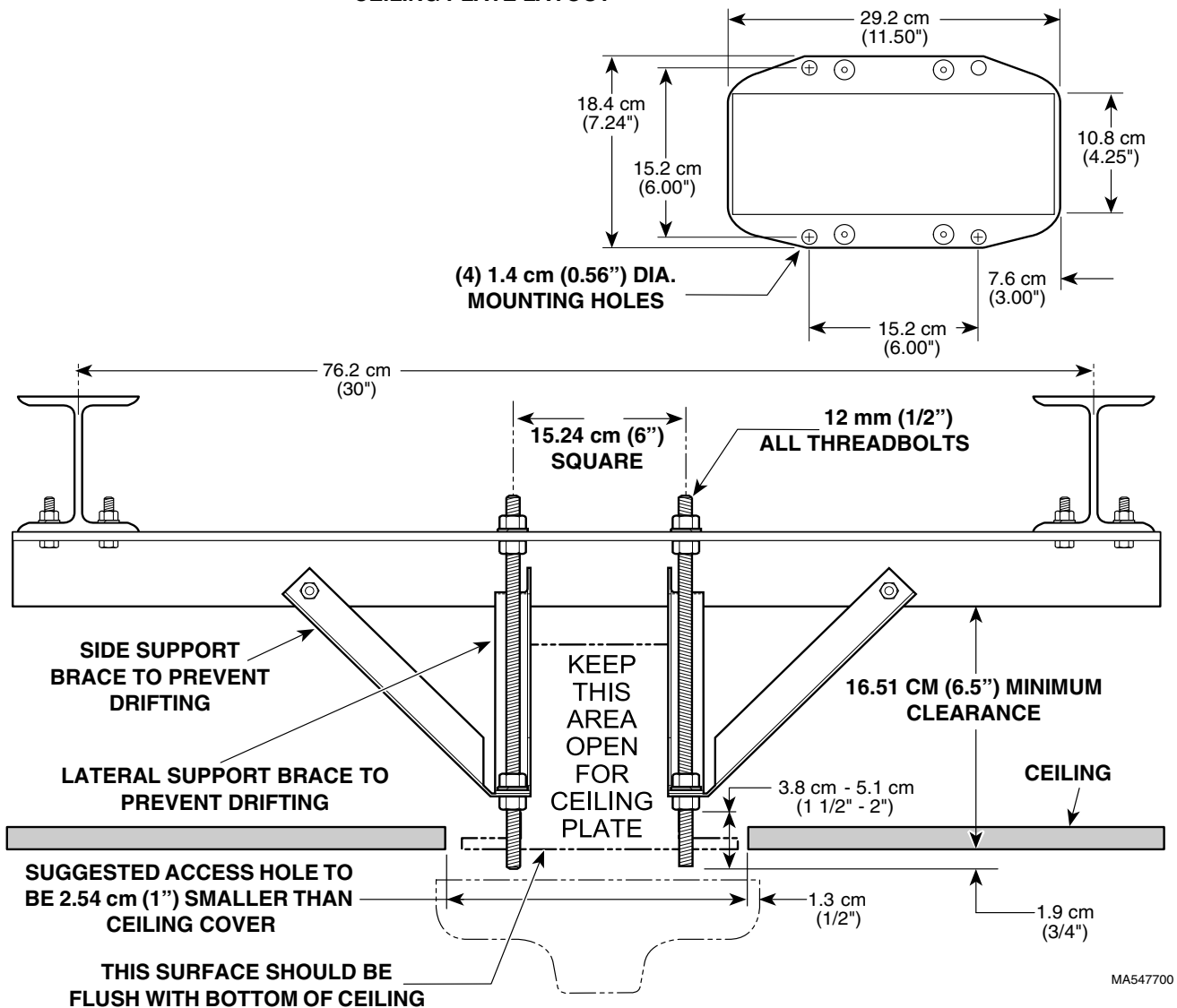

MA547700

Figure 4. Suggested Ceiling Support Structure Installation
(Illustration applies to Single and Dual Mounted Lighting Systems)

The ceiling support structure must be strong enough to uphold the weight of the system and support the rotating suspension tubes and Lighthead(s) without deflection.

The 354 lighting system is engineered for ease of movement during positioning. The suspension assemblies and lighthead(s) will rotate with a minimum of force, provided the ceiling plate assembly is level and stays level. If, however, the ceiling support is weak and flexes, the weakness will have a negative impact on the operation of the tube assemblies during positioning. If the ceiling support structure flexes too much, the lighthead(s) will drift to the lowest point. Although the arms

are equipped with brakes to prevent drift, the undesirable side effect of stiffer braking, is that the arm assemblies / lighthead(s) will be harder to move. For a set of tube assemblies to rotate without drift and a minimum amount of force, the ceiling plate assembly must not be allowed to deflect more than 1/16 in. (1.58 mm) over a 12 in. (30.5 cm) distance. The ceiling plate must be level and stay level when the tube assemblies are rotated in every position and all worst case scenarios (example: two sets of tube assemblies on one side). This means that the ceiling support structure must be braced in multiple directions.

The 354 lighting system comes in two different versions: an 8 ft. (2.44 m) version for a 8 ft. (2.44 m) ceiling and a 9 ft. (2.74 m) version for a 9 ft. (2.74 m) ceiling. The bottom of the ceiling plate assembly must be installed so it is flush with the finished surface of the facility's ceiling. See Figure 4. The ceiling cover is designed to fit up against the finished ceiling.

ELECTROMAGNETIC INTERFERENCE

This product is designed and built to minimize electromagnetic interference with other devices. However, if interference is noticed between another device and this product, remove the interfering device from the room or wire this product into an isolated circuit.

WIRING INSTALLATION

The wiring, supplying power to the junction box of the 354 lighting system, must be supplied by the customer. The 354 lighting system requires 120 VAC input voltage. The wire should be a 2-conductor with ground, 14 gauge copper wiring, rated for 120 VAC. The customer supplied wiring must be connected to the junction box with some form of strain relief fitting, preferably a conduit fitting. Connect and route the wiring in accordance with local and national codes, using conduit where necessary. See wiring diagram, Figure 5.

JUNCTION BOX WIRING CONNECTIONS (SEE FIGURE 5)



WARNING

Make sure the power to the facility supplied wiring is turned "off" for the following step. Failure to do so could result in electrical shock, causing serious personal injury or death.

- (1) Turn off facility power breaker so there **is no** power in customer supplied wiring.
- (2) Loosen, but do not remove, four screws (1, Figure 7); then pull outward on box cover (2) and remove box cover from junction box (3).
- (3) Install conduit fitting (customer supplied) in the knockout of the junction box (3).

- (4) Feed the facility supplied wiring through the knockout in the junction box (3).



WARNING

Make sure the facility supplied wiring is not shorted to the junction box and does not touch wires during steps 5 and 6. Failure to do so could result in electrical shock, causing serious personal injury or death.

- (5) Turn on facility power breaker so there **is** power in customer supplied wiring.
- (6) Using a multimeter, measure the input voltage between black power lead and white neutral lead of customer supplied wiring. Record this voltage.



WARNING

Make sure the power to the facility supplied wiring is turned "off" for the following step. Failure to do so could result in electrical shock, causing serious personal injury or death.

- (7) Turn "off" facility power breaker so there **is no** power in customer supplied wiring.
- (8) If voltage measured in step 6 was 117.0 VAC or lower, connect the white neutral lead of customer supplied wiring to the terminal marked **N/114V** for single units **or N1/114V or N2/114V** for double units (see Figure 5).
If voltage measured in step 6 was between 117.1 and 123.0 VAC, connect the white neutral lead of customer supplied wiring to the terminal marked **N/120V** for single units **or N1/120V or N2/120V** for double units (see Figure 5).
If voltage measured in step 6 was 123.1 VAC or higher, connect the white neutral lead of customer supplied wiring to the terminal marked **N/126V** for single units **or N1/126V or N2/126V** for double units (see Figure 5).
- (9) Connect the black power wire from customer supplied wiring to the terminal marked **L**.

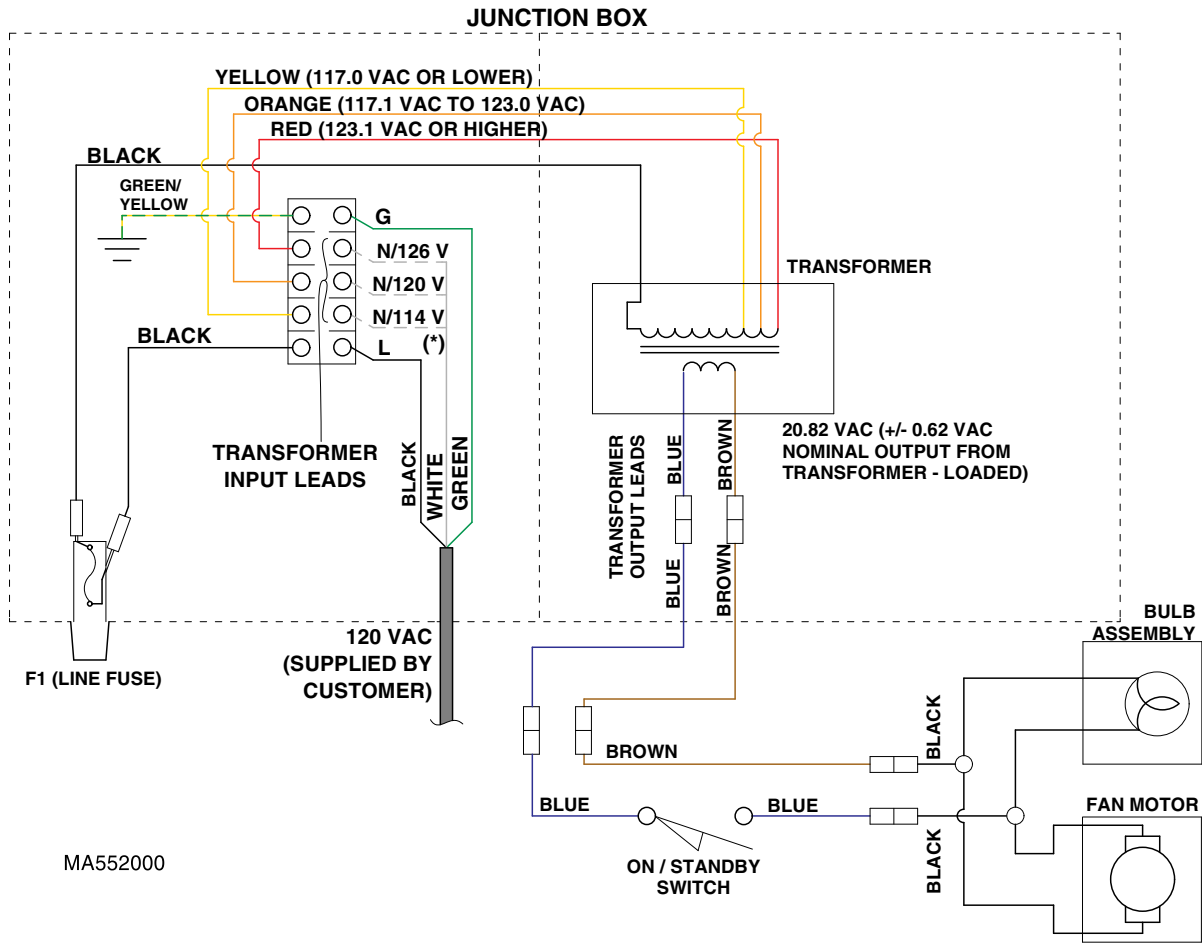

MA552000

(*) NOTE:

Select transformer input tap by measuring the input voltage. Then, connect the power lead (white wire) to one of the following according to the input voltage measured:

- 117.0 VAC or lower - Use the terminal marked N/114V.
- 117.1 VAC to 123.0 VAC - Use the terminal marked N/120V.
- 123.1 VAC or higher - Use the terminal marked N/126V.

(10) Connect the green/yellow earth ground wire from customer supplied wiring to the terminal marked with a ground symbol **G**.

(11) If light system is a dual light, the white jumper wire on the terminal block may need to be repositioned depending on the voltage measurement taken in step 6. If the voltage measurement was 117.0 VAC or lower, use white jumper wire to connect **N1/114V** to **N2/114V**. If the voltage measurement was 117.1 VAC to 123.0 VAC, keep white jumper wire where it is; connecting **N1/120V** to **N2/120V**. If the voltage measurement was 123.1 VAC or higher, use white jumper wire to connect **N1/126V** to **N2/126V**.

CAUTION

Failure to properly connect and insulate wires in junction box could result in a short or electrical shock to personnel or improper system operation.

- Always use a strain relief (conduit fitting) between facility wiring and the junction box.
- Always connect the earth ground wires inside the junction box.
- Double Units-Always make certain the white jumper wire is properly positioned.

NOTE

It is especially important to perform steps 12 and 13 now if the ceiling is a drywall/plastered ceiling; these steps will not be able to be performed later.

Figure 5 (Sheet 2 of 2). Wiring Diagram - Double Unit

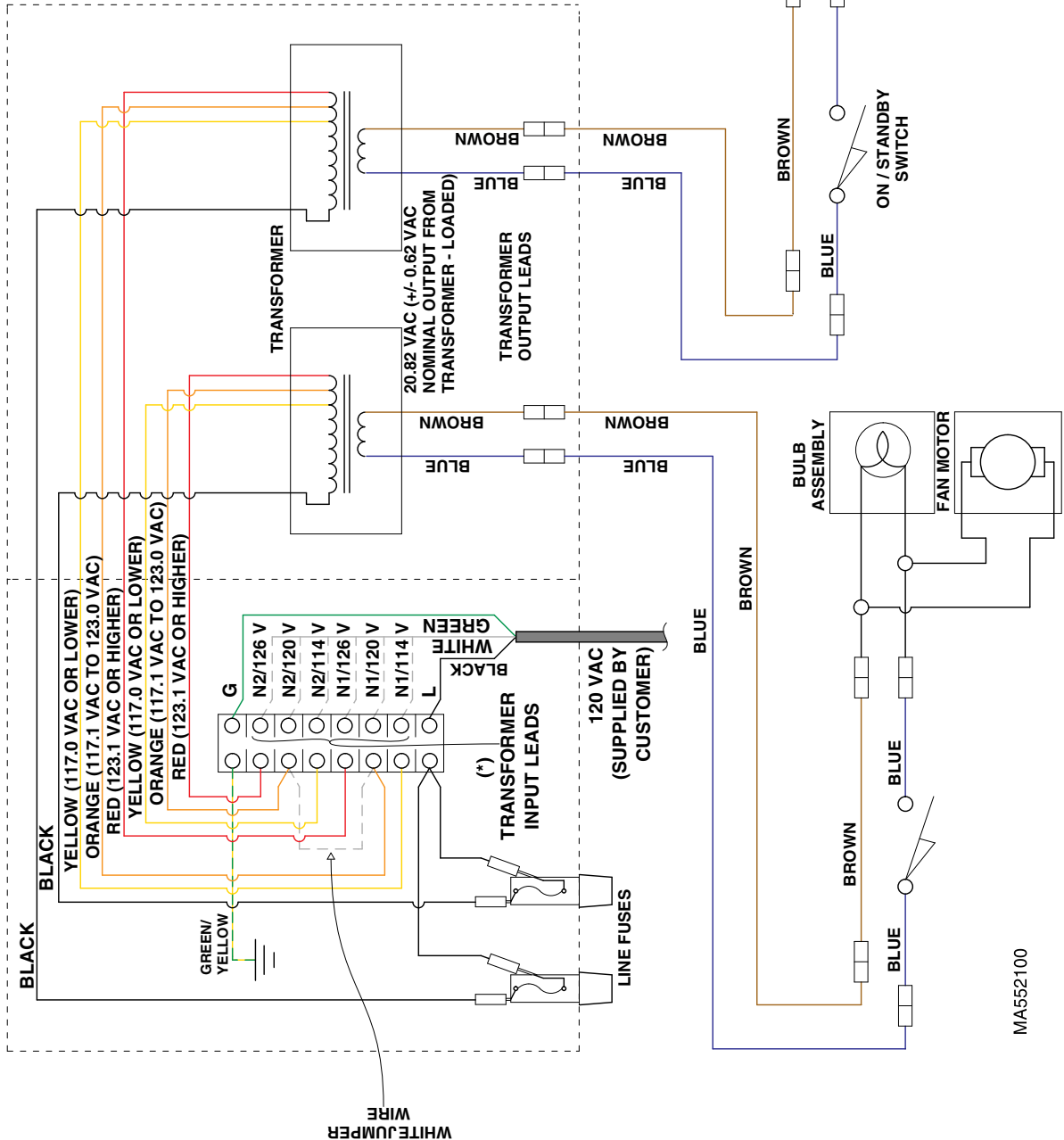

MA552100

(*) NOTE:

Select transformer input tap by measuring the input voltage. Then, connect the power lead (white wire) to one of the following according to the input voltage measured:
 117.0 VAC or lower - Use the terminal marked N1/114V or N2/114V.
 117.1 VAC to 123.0 VAC - Use the terminal marked N1/120V or N2/120V.
 123.1 VAC or higher - Use the terminal marked N1/126V or N2/126V.

- (12) Feed brown and blue transformer output wires out of wire hole (7, Figure 7) in bottom of junction box.
- (13) Position box cover (2) on junction box (3) and secure by tightening four screws (1).

CEILING PLATE ASSEMBLY INSTALLATION

NOTE

The following step describes one typical way of mounting the ceiling plate assembly. However, this method may not work for all installations; if not, use the following procedure for guidance only.

- (1) Install four 1/2" nuts (1, Figure 6) on four all-thread bolts (2) (not supplied).

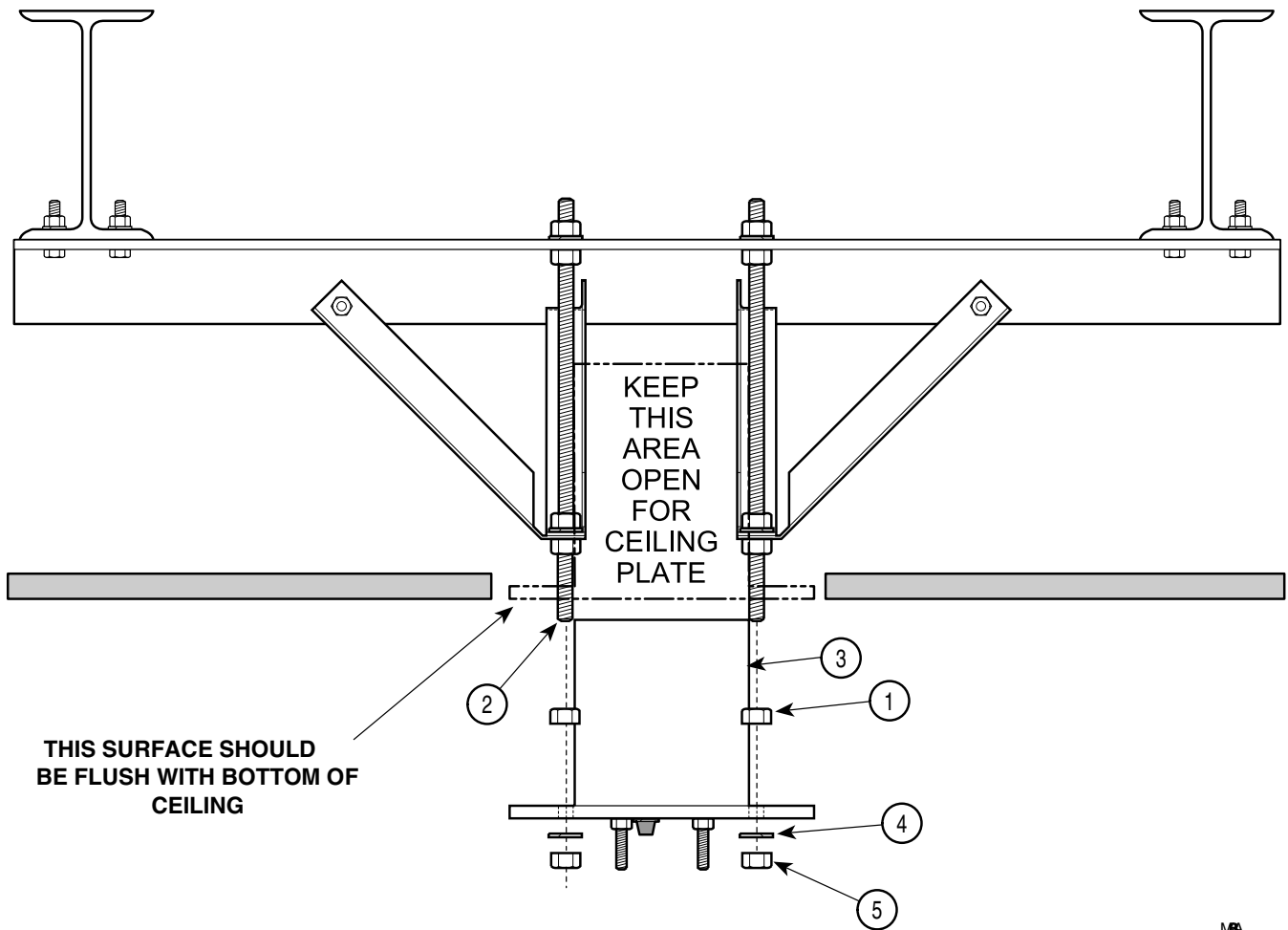

Figure 6. Suggested Ceiling Plate Assembly Installation

MA

- (2) Install ceiling plate assembly (3) on four all-thread bolts (2) and secure with four 1/2" lockwashers (4) and 1/2" nuts (5).

NOTE

For the following step, make sure nuts (1) **are not** contacting the ceiling plate assembly (3). Otherwise, leveling of ceiling plate assembly with nuts (5) will not be possible.

- (3) Adjust four nuts (5) until bottom of ceiling plate assembly (3) is flush with surface of ceiling.



WARNING

Failure to install nuts (5) so that there are at least two full threads visible below nuts, could result in unit falling.

- (4) Use a level to check the levelness of ceiling plate assembly (3) in all directions. Adjust four nuts (5) as necessary until the ceiling plate assembly (3) is level in all directions and flush with surface of ceiling.
- (5) Tighten nuts (1) against ceiling plate assembly (3); then recheck levelness of ceiling plate and readjust if necessary.

DOWN TUBE INSTALLATION

- (1) Thread three 3/8" x 16 hex nuts (4, Figure 7) (supplied) onto three bolts (5) until they are handtight; then back off each nut one full turn.
- (2) Position down tube (6) near wire hole (7).
- (3) Connect brown wire (S2) from junction box (3) to brown wire (A) from down tube (6).
- (4) Connect blue wire (S1) from junction box (3) to blue wire (B) from down tube (6).
- (5) Install down tube (6) on three bolts (5) and secure with three 3/8" lockwashers (8) and 3/8" x 16 hex nuts (9) (supplied).



WARNING

Failure to install nuts (9) so that there are at least two full threads visible below nuts, could result in unit falling.

- (6) Under normal circumstances, the down tube (6) should be level enough to provide drift-free operation. If, after complete assembly and operation of the light system, drifting is observed, use a protractor or level (C) to adjust nuts (9) until down tube (6) is vertical (+/- 0.5°); then tighten nuts (4).
- (7) If light system is a dual light, repeat steps 1 through 6 for remaining down tube (6).
- (8) Slide ceiling cover (10) onto down tube(s) (6).
- (9) Attach ceiling cover (10) to ceiling plate (11) with four #10-24 x 3/4" screws (12) (supplied).

CROSS TUBE ASSEMBLY INSTALLATION



EQUIPMENT ALERT

When assembling a dual light system combination consisting of a model 354 mounted in combination with a model 355, special care must be taken to ensure that the proper transformer is used for each cross tube / lighthead assembly. Failure to do so may result in a blown fuse and / or bulb. The transformer output voltage is different for the two models. The model 354 transformer is labeled with part number 015-1206-00 and its secondary leads are marked S1 and S2. The Model 355 transformer is labeled with part number 015-1356-00 and its secondary leads are not marked.

- (1) Slide ball pivot sleeve (1, Figure 8) onto down tube (2), making sure screw hole in sleeve is on the bottom.
- (2) With ball pivot sleeve (1) positioned as high as possible on down tube (2), pull blue and brown wires (6) through top window (A) of down tube.

NOTE

There are three screw holes in cross tube (3); two of the holes are larger and have a coarser thread. Use these two holes to secure cross tube assembly with screws (5). The other hole is for securing ball pivot sleeve.

- (3) Align three screw holes; then insert pivot shaft of cross tube assembly (3) into down tube (2). Secure cross tube assembly in position with two #10-24 x 3/8" black oxide button head screws (5).
- (4) Feed two wires (4) through top window (A) of down tube (2).

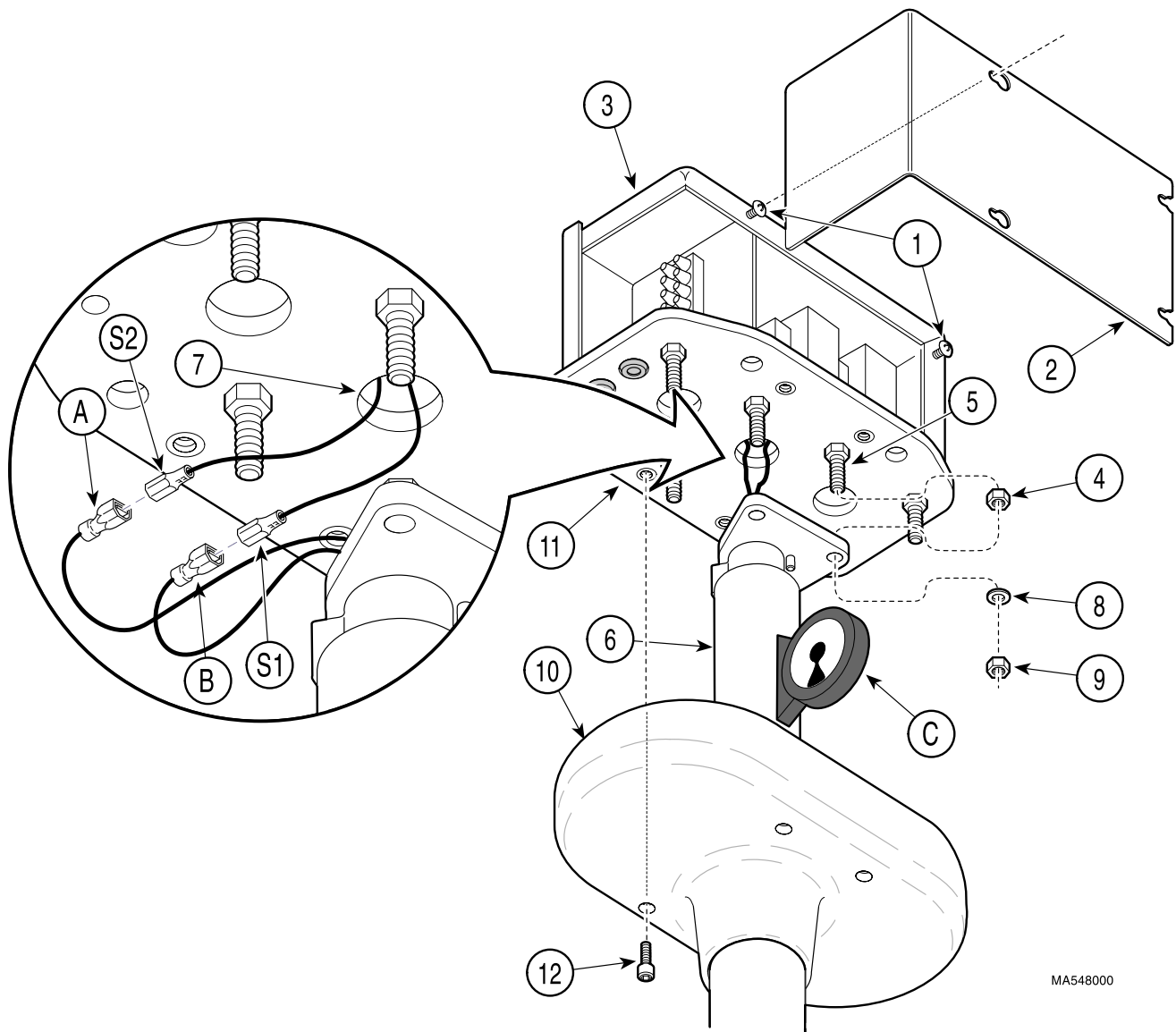

MA548000

Figure 7. Down Tube Installation

- (5) Connect brown wire (4) to brown wire (6) and blue wire (4) to blue wire (6). Push wires into top window (A).
- (6) Slide ball pivot sleeve (1) down into position and secure with one #10-24 x 3/8" (New Units Only) pan head screw(7) (Refer to Page 5).
- (7) If light system is a dual light, repeat steps 1 thru 6 for the remaining cross tube assembly. Special care must be taken when assembling a 354 / 355 combination unit as noted in the Equipment Alert.

HOUSING CAP INSTALLATION

- (1) Install housing cap (2, figure 11) on ballast housing (3) and secure with screw (1).

OPERATIONAL TEST

- (1) Turn the ON / STANDBY switch (1, Figure 9) to ON "I".
- (2) Observe. The lighthouse (2) should illuminate and the fan in the back of the lighthouse should be operating.

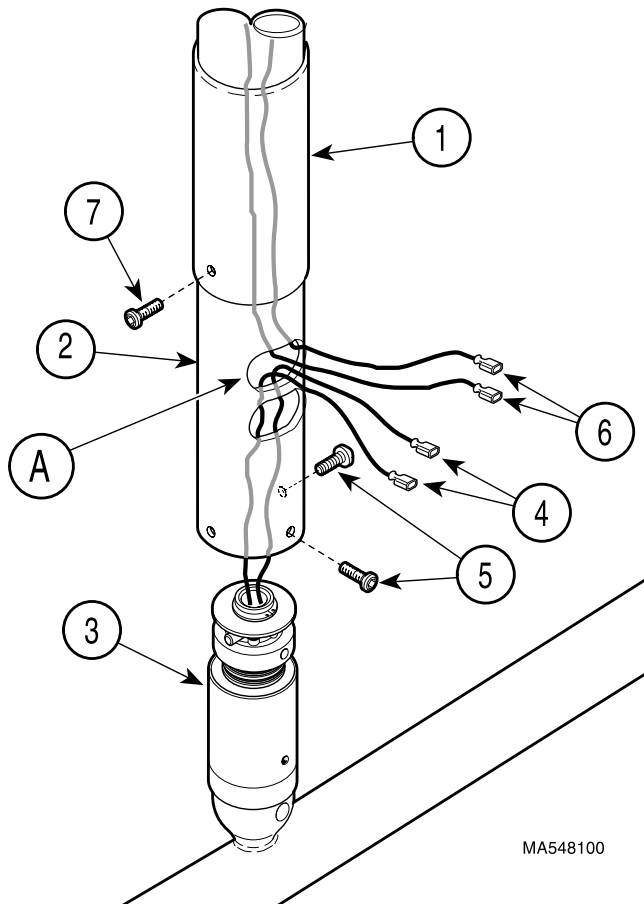

Figure 8. Cross Tube Assembly Installation

- (3) Position the lighthouse (2) 36 in. (91.4 cm) from a table and aim the light beam at the table.
- (4) Observe. There should be a circular pattern of bright light on the table surface.

- (5) Rotate the lighthouse (2), lamp tube (3), cross tube (4), and down tube (5) through their range of motions as shown on the illustration. Release the lighthouse at different positions.
- (6) Observe. The lighthouse (2) should be able to be positioned easily through the entire range of its motion. When the lighthouse is released in any position, no drifting should occur at any axis.
- (7) Adjust the brightness control lever (6) through its range of motion.
- (8) Observe. The light beam should brighten / darken as the brightness control lever (6) is adjusted.
- (9) Adjust the brightness control lever (6) to achieve maximum brightness, then adjust the beam size lever (7) through its range of motion.
- (10) Observe. The light beam pattern should change from approximately 3 in. to 10 in. (7.6 to 25.4 cm) as the beam size lever (7) is adjusted.
- (11) If any problems are discovered, refer to the troubleshooting guide for adjustment and repair tips.

TROUBLESHOOTING

TROUBLESHOOTING GUIDE

If any problems are discovered during the installation process, refer to the following table (Table 1) to determine the cause of the problem.

Table 1. Troubleshooting Guide

| PROBLEM | POSSIBLE CAUSE | SOLUTION |
|---|--|---|
| no light from lighthouse | <i>lighthouse is on STANDBY "⏻"</i> | turn ON / STANDBY switch to ON "⏻" |
| no light from lighthouse, but ON / STANDBY switch is ON "⏻" | <i>bulb has burned out or has not been installed</i> | refer to bulb replacement procedure in this manual |
| | <i>fuse in junction box is blown</i> | inspect / replace the fuse located inside the ceiling cover |
| | <i>no power to the junction box</i> | check for facility power to the junction box |
| | <i>transformer is malfunctioning</i> | check for 20.8 VAC output at the transformer when it is under load. |

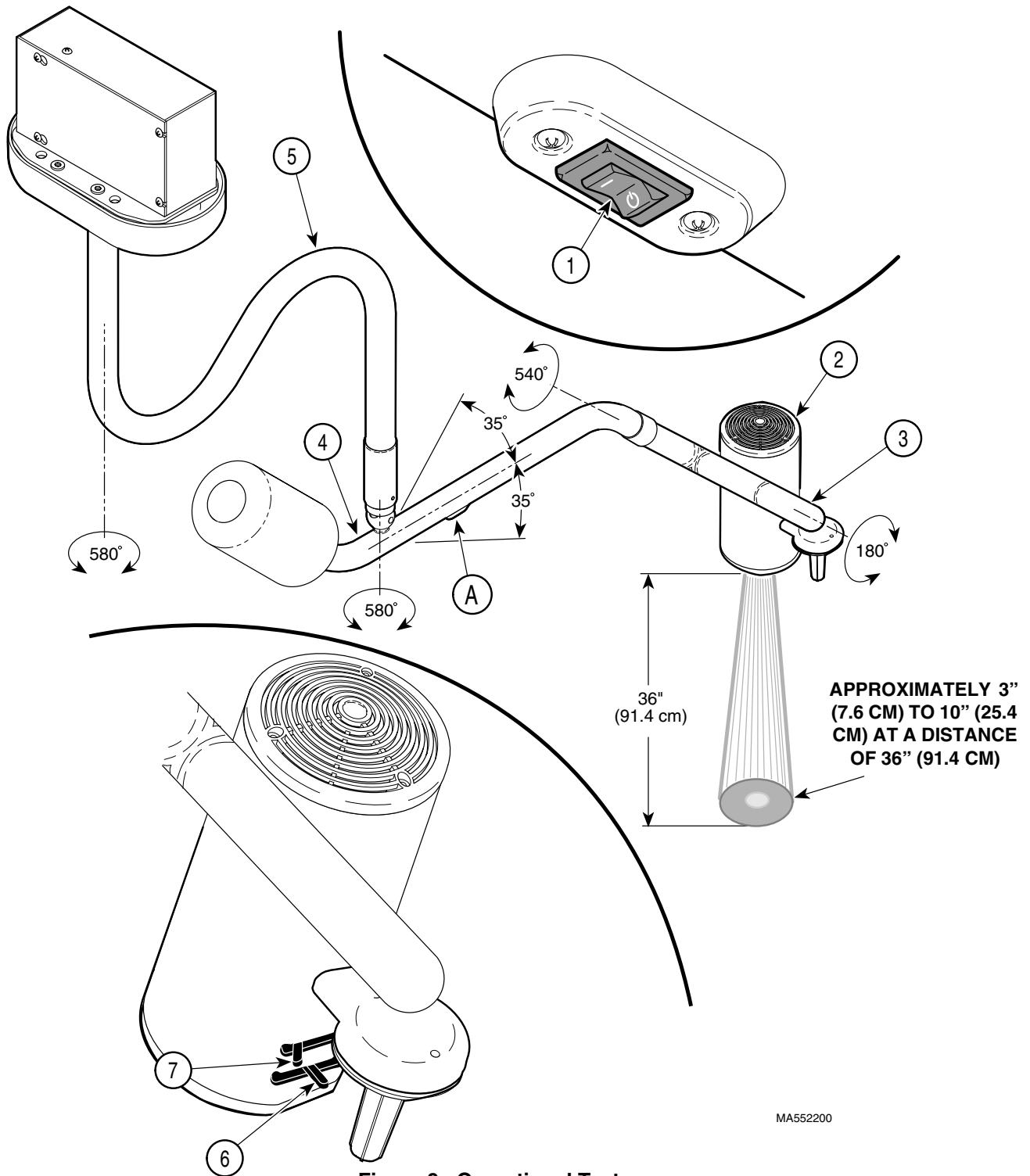

Figure 9. Operational Test

Table 1. Troubleshooting Guide - Continued

| | | |
|---|--|---|
| no light from lighthouse although the bulb and fuse were checked; lighthouse flashes intermittently when lighthouse or arms are moved | <i>circuit or wiring problem within arm assemblies, junction box, or other part of lighting system</i> | check all wiring connections. If problem cannot be repaired, call Midmark Technical Support: 1-800-Midmark. |
| down tube does not rotate freely or drifts when released in desired position | <i>improper installation of ceiling plate (deflects too much or is not level)</i> | check for excessive flexing of ceiling support structure and / or check if ceiling plate is level. Readjust as necessary. |
| lamp tube does not rotate freely or drifts when released in desired position | <i>brake tension needs adjusted</i> | call Midmark Technical Support: 1-800-Midmark |
| cross tube rotates (at ball pivot joint) too stiffly or drifts when released in desired position | <i>ball pivot joint tension needs to be adjusted or cross tube counterbalance needs adjusted</i> | refer to ball pivot joint tension adjustment procedure in this manual. If proper tension cannot be achieved, refer to cross tube counterbalance adjustment procedure in this manual and then repeat main pivot joint tension adjustment. If problem cannot be repaired, call Midmark Technical Support: 1-800-Midmark |
| lighthouse does not rotate freely at lamp tube or drifts when released in desired position | <i>brake needs adjustment</i> | call Midmark Technical Support: 1-800-Midmark |

ADJUSTMENTS

BALL PIVOT TENSION ADJUSTMENT

- (1) Remove screw (1, Figure 10) and slide ball pivot sleeve (2) up out of way.

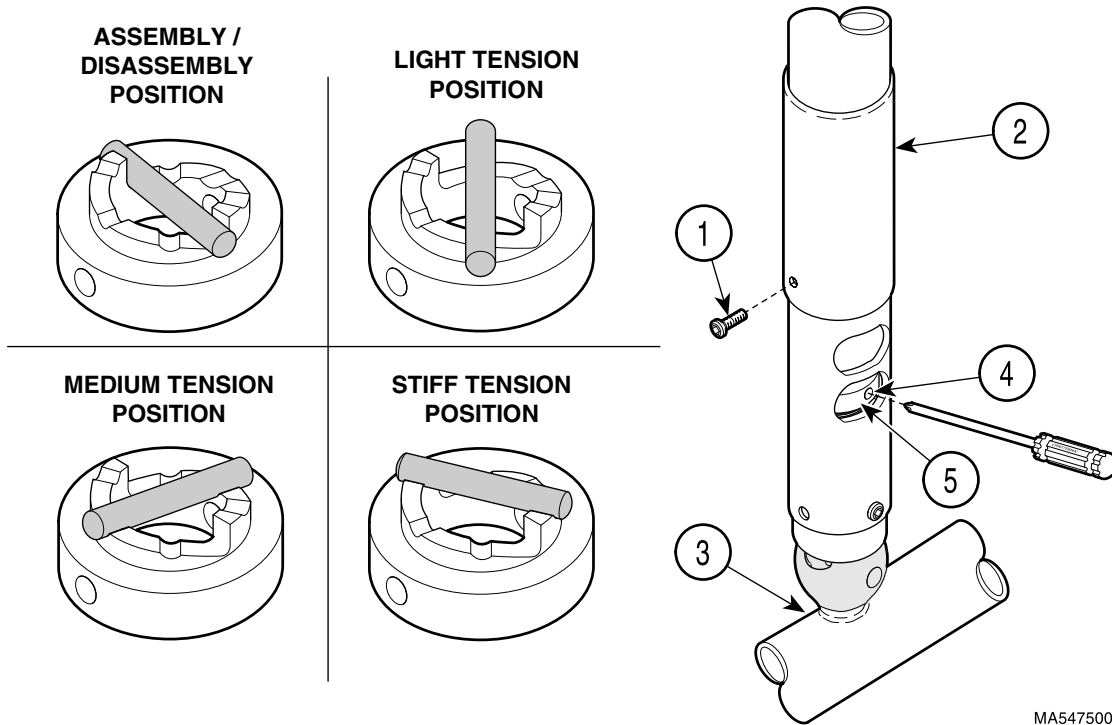

Figure 10. Ball Pivot Joint Tension Adjustment

- (2) Rotate cross tube (3) until adjustment hole (4) appears in the adjustment window opening.

NOTE

There are three settings which the ball pivot cam (5) can be set for: light tension, medium tension, or stiff tension (see Figure 10). These settings may be changed according to the operator's preference.

- (3) Insert screwdriver into adjustment hole (4). Then, using the screwdriver, rotate ball pivot cam (5) to the desired tension setting.
- (4) Remove the screwdriver and move the cross tube (3) about the ball pivot joint in a circular motion and up and down motion to ensure the setting is the one desired. Move the cross tube (3) to a horizontal position and release it. The cross tube should not drift in any direction. If it does, a higher

tension setting is required. Repeat steps 3 and 4 until the desired tension adjustment is achieved with no drifting of the cross tube. If a satisfactory tension adjustment cannot be achieved, perform the cross tube counterbalance adjustment procedure and then repeat the ball pivot joint tension adjustment procedure.

- (5) Slide ball pivot sleeve (2) down into position and secure with screw (1).

CROSS TUBE COUNTERBALANCE ADJUSTMENT

- (1) Remove screw (1, Figure 10) and slide ball pivot sleeve (2) up out of way.
- (2) Rotate cross tube (3) until adjustment hole (4) appears in the adjustment window opening.

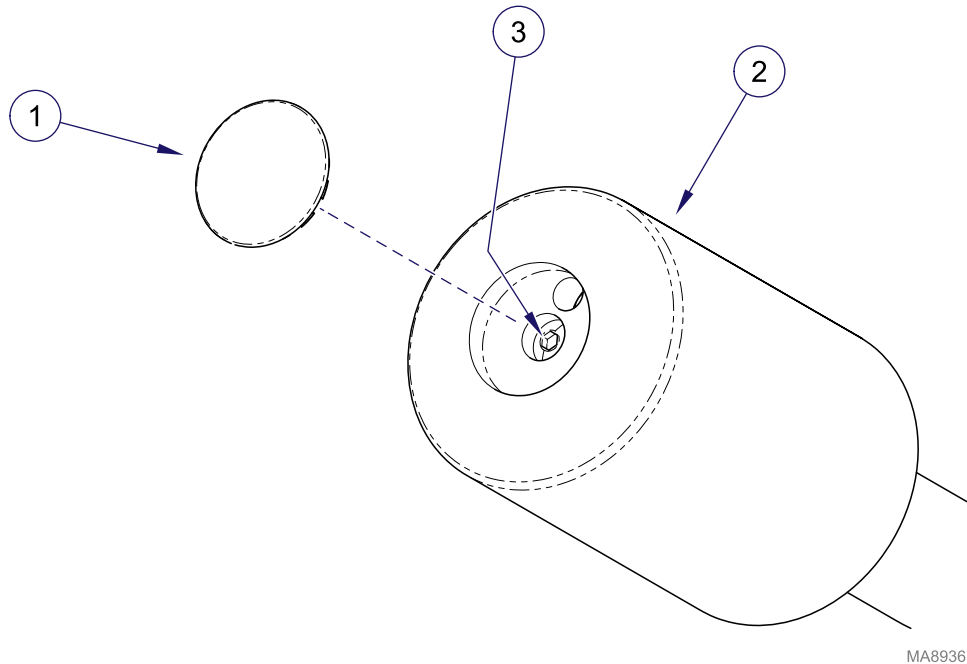

Figure 11. Cross Tube Counterbalance Adjustment

- (3) Insert screwdriver into adjustment hole (4). Then, using the screwdriver, rotate ball pivot cam (5) to the assembly / disassembly setting. Remove screwdriver.
- (4) Remove housing cap (1, Figure 11) from ballast housing (2).

NOTE

One way to determine if the cross tube is balanced properly is to raise the cross tube above horizontal, release it, and observe where it stops. Then, lower the cross tube below horizontal plane, release it, and observe where it stops. The cross tube should return to the horizontal position and remain there; if it does, the cross tube counterbalance is adjusted properly.

Turning screw (3) in clockwise direction will lower the lighthead end of cross tube. Turning screw (3) in counterclockwise direction will raise the lighthead end of cross tube.

- (5) Adjust screw (3) until cross tube balances in a horizontal position.

- (6) Install housing cap (1) on ballast housing (2)

NOTE

It is recommended that you start with the light setting and then proceed to the medium or stiff setting only if necessary to prevent drifting.

- (7) Insert screwdriver into adjustment hole (4, Figure 10). Then, using the screwdriver, rotate ball pivot cam (5) to the light, medium, or stiff setting as desired by the operator(s). Remove screwdriver.
- (8) Slide ball pivot sleeve (2) down into position and secure with screw (1).

LIGHT DIMENSIONS

Height and Clearance Dimension

1. Use this graphic to help determine proper positioning of light at the time of installation.

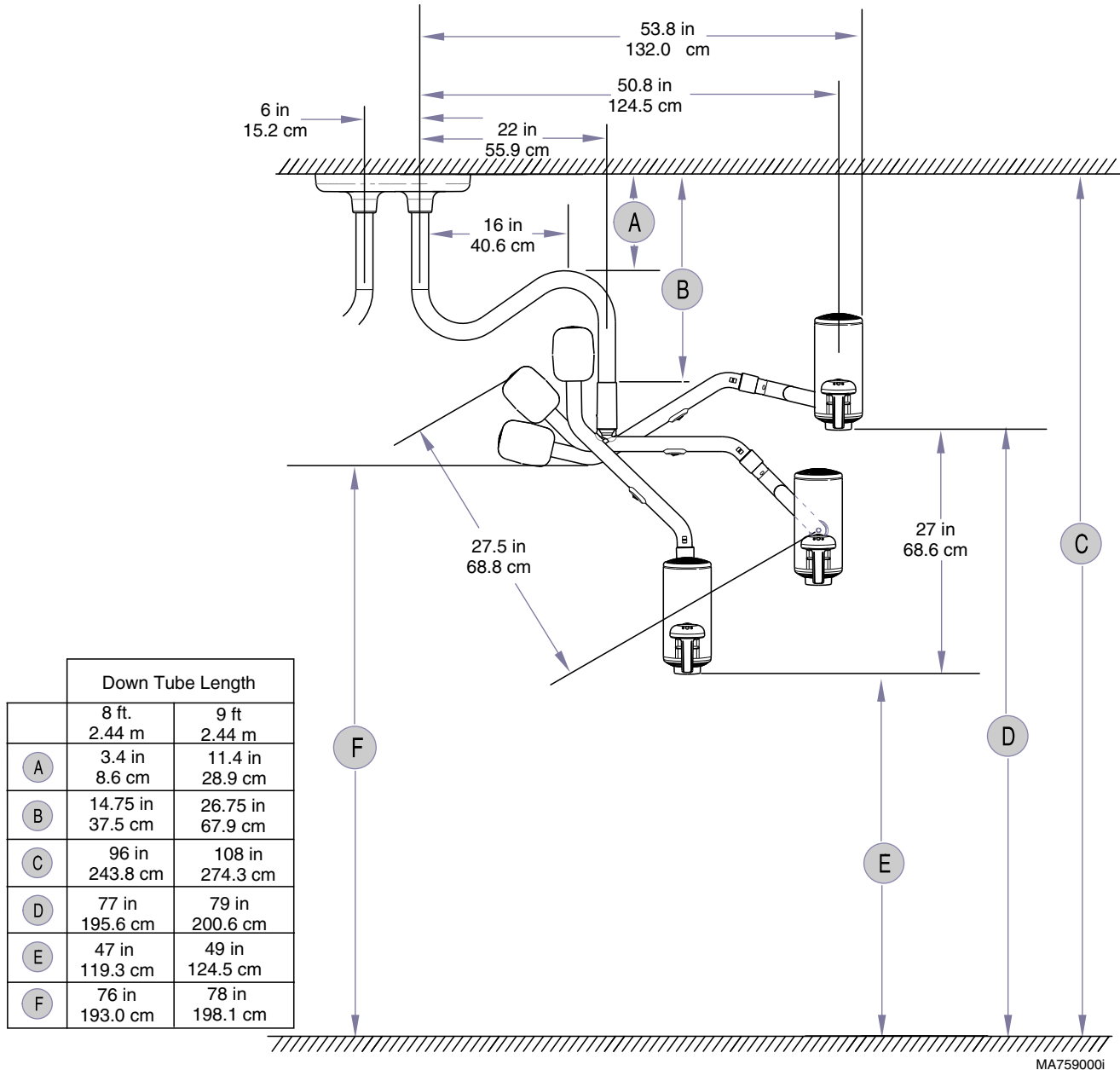

Figure 12. Height and Clearance Dimensions

CALLING FOR SERVICE

If you are having a problem or have a question, refer to the inside front cover of this manual and call your dealer. Make sure that you have the information that is highlighted on the inside front cover of this manual available. If you can't resolve your question or problem with your dealer, call the following number:

1-800-Midmark (1-800-643-6275) or 937-526-3662
8:00 a.m. until 5:00 p.m. (Eastern
Standard Time in U.S.)
Monday through Friday, except for
standard U.S. holidays.

LIMITED WARRANTY

SCOPE OF WARRANTY

Midmark Corporation ("Midmark") warrants to the original purchaser its new Alternate Care products and components (except for components not warranted under "Exclusions") manufactured by Midmark to be free from defects in material and workmanship under normal use and service. Midmark's obligation under this warranty is limited to the repair or replacement, at Midmark's option, of the parts or the products the defects of which are reported to Midmark within the applicable warranty period and which, upon examination by Midmark, prove to be defective.

APPLICABLE WARRANTY PERIOD

The applicable warranty period, measured from the date of delivery to the original user, shall be one (1) year for all warranted products and components.

EXCLUSIONS

This warranty does not cover and Midmark shall not be liable for the following: (1) repairs and replacements because of misuse, abuse, negligence, alteration, accident, freight damage, or tampering; (2) products which are not installed, used, and properly cleaned as required in the Midmark "Installation" and or "Installation / Operation Manual for this applicable product. (3) products considered to be of a consumable nature; (4) accessories or parts not manufactured by Midmark; (5) charges by anyone for adjustments, repairs, replacement parts, installation, or other work performed upon or in connection with such products which is not expressly authorized in writing in advance by Midmark.

EXCLUSIVE REMEDY

Midmark's only obligation under this warranty is the repair or replacement of defective parts. Midmark shall not be liable for any direct, special, indirect, incidental, exemplary, or consequential damages or delay, including, but not limited to, damages for loss of profits or loss of use.

NO AUTHORIZATION

No person or firm is authorized to create for Midmark any other obligation or liability in connection with the products.

THIS WARRANTY IS MIDMARK'S ONLY WARRANTY AND IS IN LIEU OF ALL OTHER WARRANTIES, EXPRESS OR IMPLIED. MIDMARK MAKES NO IMPLIED WARRANTIES OF ANY KIND INCLUDING ANY WARRANTIES OF MERCHANTABILITY OR FITNESS FOR ANY PARTICULAR PURPOSE. THIS WARRANTY IS LIMITED TO THE REPAIR OR REPLACEMENT OF DEFECTIVE PARTS.

SF-1487 REV. A1

NOTES:

NOTES:

Midmark Corporation
60 Vista Drive
Versailles, OH 45380 USA
1-800-643-6275
1-937-526-3662
www.midmark.com



Because we care.

© Midmark Corporation - 1999

003-1067-00 Rev. P (5/21/13)