



Rocker Arm / Stop Pin Replacement [002-1376-0x]

Components:

Rocker Arm.....	1
Spring	1
Shoulder Screw	2
Stop Pin	1
Washer	2

Step 1: Position the chair.
 A) Raise chair until seat is 26" to 28" above floor.
 B) Disconnect power to chair.

Note: Upper lift arm cover cannot be removed if seat is higher than 28".

Step 2: Remove upper lift arm cover.
 A) Using a screwdriver, push in on center clips.
 B) Lift cover up to release front clips.



Step 3: Remove lower lift arm cover.
 A) Working one side at a time, move cover to the side and back to release from mounting pins.

WARNING
 Always disconnect power to the chair before removing covers.

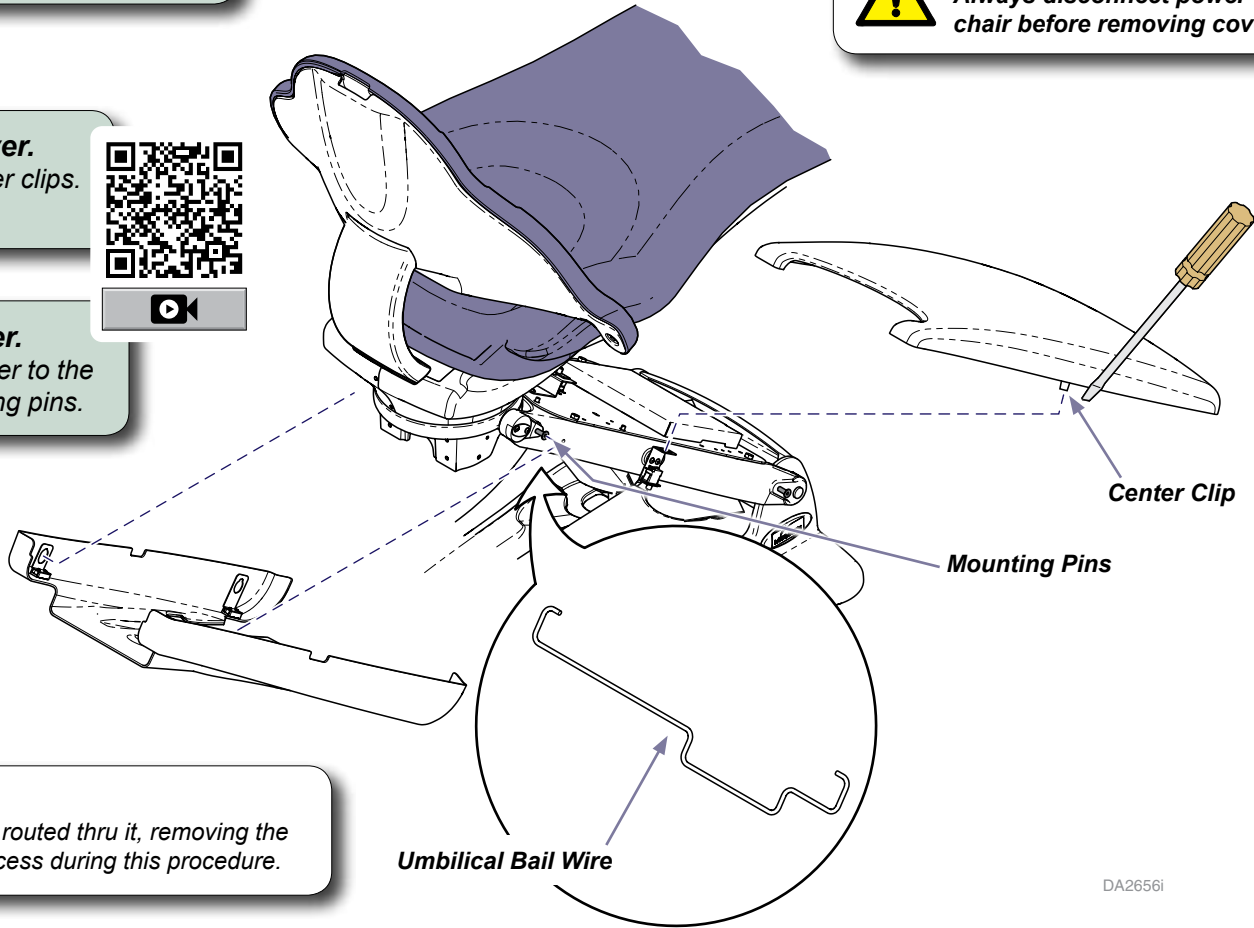

Note
 If the chair has an umbilical routed thru it, removing the bail wire will allow better access during this procedure.

DA2656i

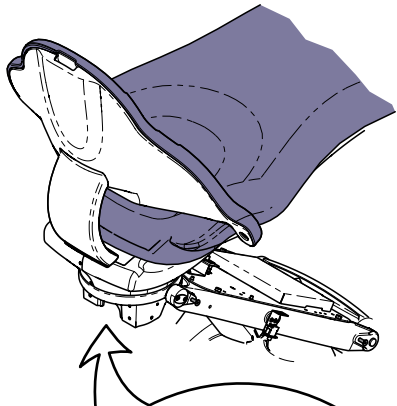

Step 4: Remove brake cover plate.

- A) Remove screw and cable clamp from cover plate.
- B) Remove one screw and brake cover plate.

Step 6: Remove rocker arm / stop pin.

- A) Remove two shoulder screws, washers, and rocker arm.
- B) Pull stop pin out to remove.

Note: Use a long, straight 3/32" allen wrench to remove shoulder screws.

Step 5: Remove pivot plug and spring.

- A) Push pivot plug in.
- B) Reach under the seat to remove spring and pivot plug.

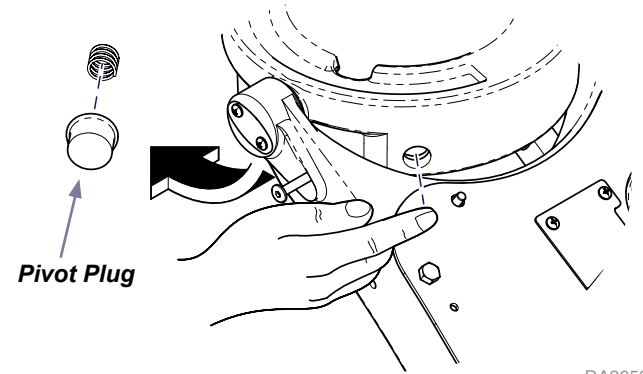

DA2658i

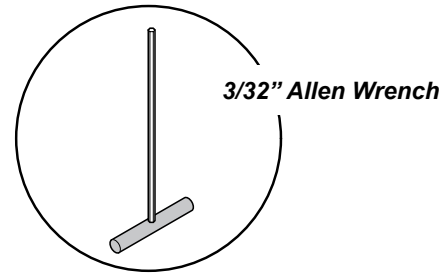
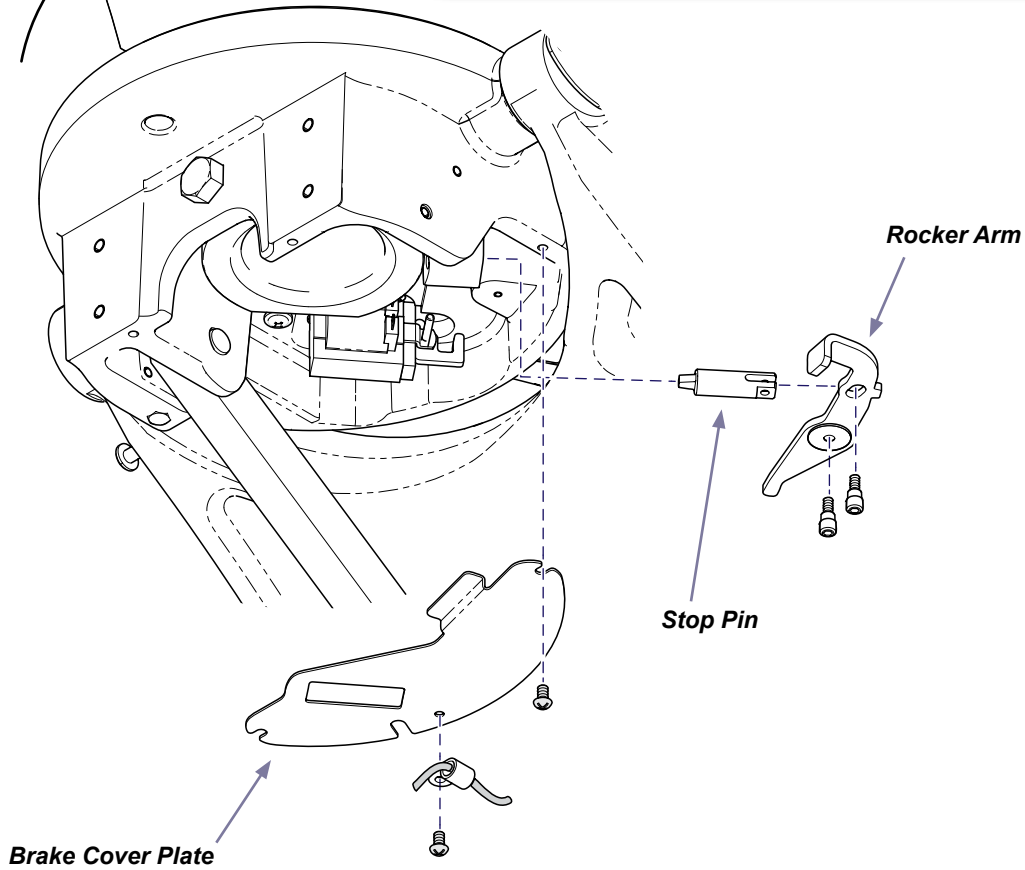

DA2659i

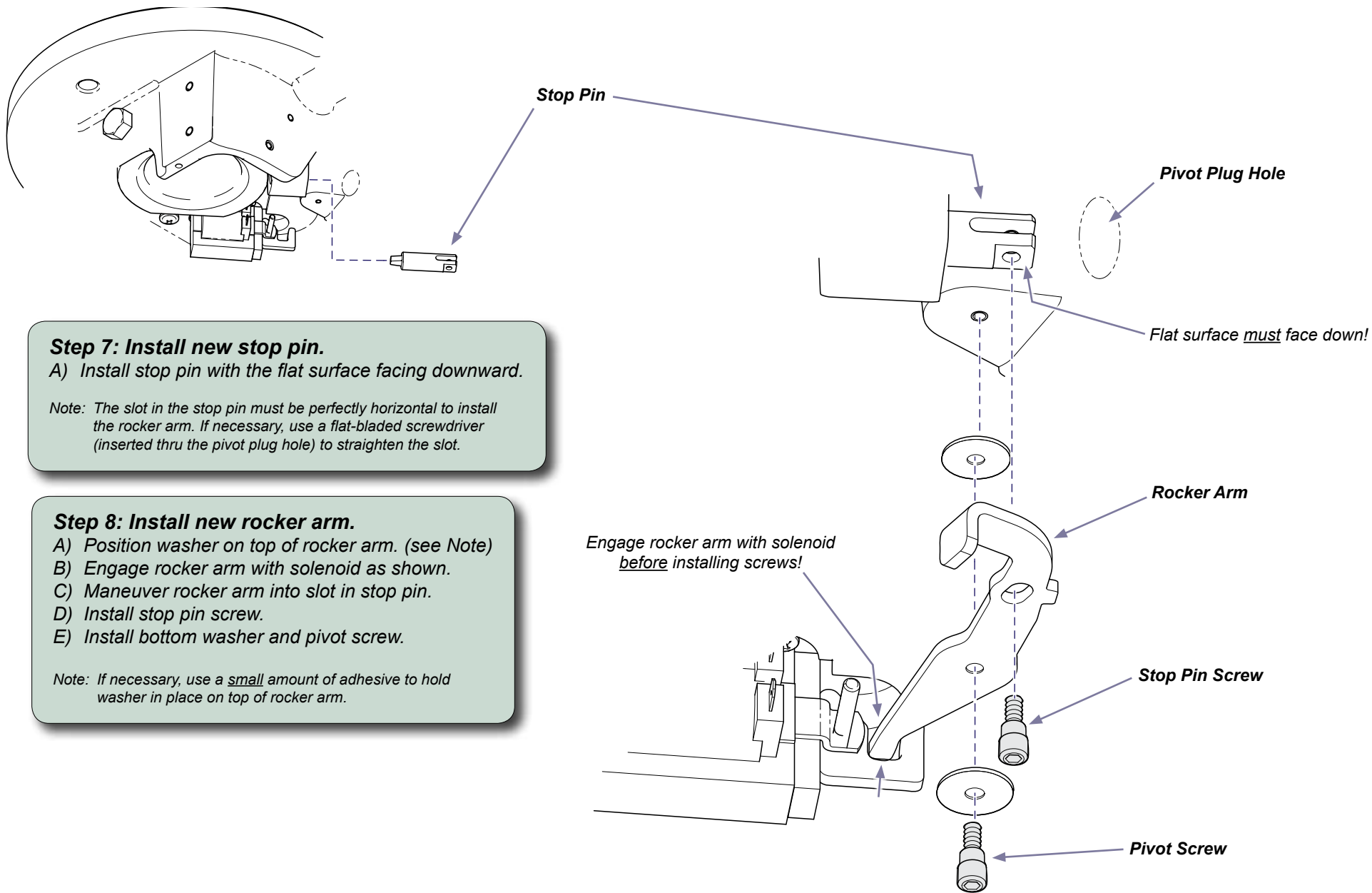

Step 7: Install new stop pin.

A) Install stop pin with the flat surface facing downward.

Note: The slot in the stop pin must be perfectly horizontal to install the rocker arm. If necessary, use a flat-bladed screwdriver (inserted thru the pivot plug hole) to straighten the slot.

Step 8: Install new rocker arm.

- A) Position washer on top of rocker arm. (see Note)
- B) Engage rocker arm with solenoid as shown.
- C) Maneuver rocker arm into slot in stop pin.
- D) Install stop pin screw.
- E) Install bottom washer and pivot screw.

Note: If necessary, use a small amount of adhesive to hold washer in place on top of rocker arm.

DA2660i

Step 9: Install pivot plug / spring.

- A) Insert pivot plug into the hole in casting.
- B) Compress the spring, then move it into position on the rocker arm. When properly positioned, the pivot plug will snap into the pivot plug.

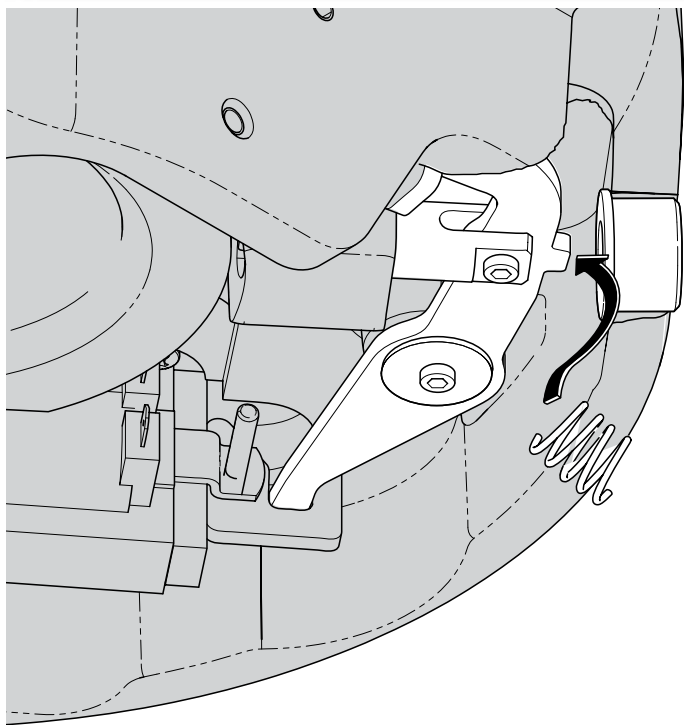

Step 10: Install brake cover plate.

- A) Position the cover plate and secure with screw.
- B) Secure cable clamp with screw.

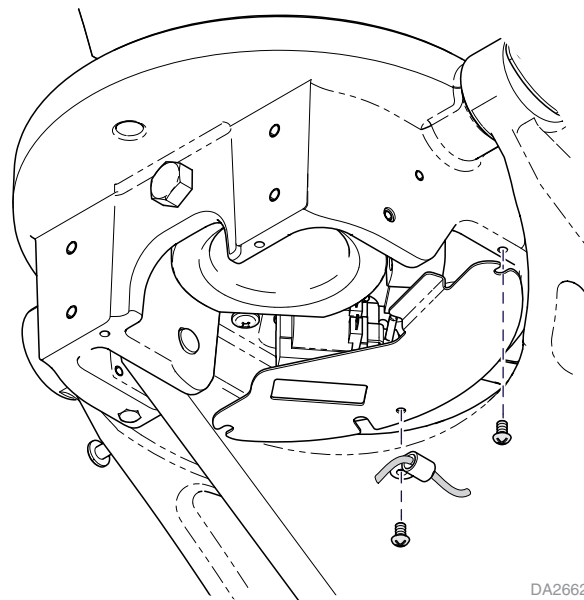

Refer to illustration on page one to complete Step 10.

Step 11: Install base covers / bail wire.

- A) If removed, install umbilical bail wire.
- B) Install upper and lower lift arm covers.