

Compliance Information

FCC Compliance Statement

This equipment has been tested and found to comply with the limits for a Class A digital device, pursuant to part 15 of the FCC rules. These limits are designed to provide reasonable protection against harmful interference when the equipment is operated in a commercial environment. This equipment generates, uses, and can radiate radio frequency energy and, if not installed and used in accordance with the instruction manual, may cause harmful interference to radio communications. Operation of this equipment in a residential area is likely to cause harmful interference in which case the user will be required to correct the interference at their own expense.

Any modifications to this product may violate the rules of the Federal Communications Commission and make operation of the product unlawful.

This device complies with Part 15 of the FCC Rules. Operation is subject to the following two conditions: (1) This device may not cause harmful interference, and (2) this device must accept any interference received, including interference that may cause undesired operation.

Warranty

SCOPE OF WARRANTY Midmark Corporation ("Midmark") warrants to the original retail purchaser that it will, at Midmark's option, repair or replace components of the domestic and international medical products manufactured by Midmark (except for components not warranted under "Exclusions") that are defective in material or workmanship under normal use and service. The sole remedy under this limited warranty is the repair or replacement, at Midmark's option, of the applicable components. This limited warranty shall only apply to defects that are reported to Midmark within the applicable warranty period and which are determined to exist upon examination by Midmark. This warranty extends only to the original retail purchaser of a product and is not transferable or assignable. Replacement components or products may be used and/or refurbished components or products, provided they are of like quality and specifications as new components or products.

Midmark warrants to the original retail purchaser that during the applicable warranty period it will repair or replace software contained within the products manufactured by Midmark (except for those not warranted under "Exclusions") if: (1) the media on which the software is furnished exhibits defects in material or workmanship under normal use; or (2) the software does not substantially conform to its published specifications.

APPLICABLE WARRANTY PERIOD The applicable warranty period, measured from the date of invoice to the original retail purchaser of the product and shall be one (1) year for all warranted products and components.

OBTAINING WARRANTY SERVICE Warranty service must be obtained through either Midmark or an authorized dealer in the Midmark product line for which warranty service is requested. Midmark may be contacted for warranty service inquiries or issues via email at www.midmark.com; by phone at 1-800-MIDMARK or by mail to Midmark Corporation, 60 Vista Drive, Versailles, Ohio 45380. It is the retail purchaser's obligation to arrange for delivery of a product to Midmark or one of its authorized dealers for warranty service, which delivery shall be at retail purchaser's expense. It is also the retail purchaser's obligation to comply with the warranty service instructions provided either by Midmark or its authorized dealer. The retail purchaser must provide Midmark with completed warranty registration information within thirty (30) days after purchase in order to obtain the benefits of this limited warranty.

EXCLUSIONS: This limited warranty does not cover and Midmark shall not be liable for the following:

- (1) Defects, damage or other conditions caused, in whole or in part, by misuse, abuse, negligence, alteration, accident, freight damage, negligent storage, tampering or failure to seek and obtain repair or replacement in a timely manner;
- (2) Products which are not installed, used, and properly cleaned and maintained as required or recommended in the Midmark "Installation" and/or "Installation/Operation Manual" for the applicable product, including the specified structural and operational environmental conditions and electrical requirements;
- (3) Products considered to be of a consumable or sterile nature;
- (4) Accessories or parts not manufactured by Midmark;
- (5) Charges by anyone for adjustments, repairs, replacement parts, installation or other work performed upon or in connection with such products which are not expressly authorized in writing in advance by Midmark;
- (6) Costs and expenses of routine maintenance and cleaning; and
- (7) Representations and warranties made by any person or entity other than Midmark.
- (8) Matching of color, grain or texture except to commercially acceptable standards;
- (9) Changes in color caused by natural or artificial light;
- (10) Custom manufactured products;
- (11) Alterations or modifications to the product by any person or entity other than Midmark; and

(12) Products that would otherwise be covered under this limited warranty, but are acquired: (i) from a person or entity that is not Midmark or one of its authorized dealers; or (ii) from a Midmark dealer that is not authorized to sell the product at issue in the geographic territory where the purchaser is located, or is not authorized to sell the product at issue within the medical market.

SOFTWARE; WITH RESPECT TO SOFTWARE THAT IS A PRODUCT OR COMPONENT THEREOF, MIDMARK DOES NOT WARRANT THAT THE SOFTWARE: (1) IS ERROR FREE; (2) CAN BE USED WITHOUT PROBLEMS OR INTERRUPTIONS; OR (3) IS FREE FROM VULNERABILITY TO INTRUSION OR ATTACK BY VIRUSES OR OTHER METHODS.

EXCLUSIVE REMEDY; CONSEQUENTIAL DAMAGES DISCLAIMER MIDMARK'S ONLY OBLIGATION UNDER THIS LIMITED WARRANTY IS THE REPAIR OR REPLACEMENT OF DEFECTIVE PARTS. MIDMARK SHALL NOT BE LIABLE FOR AND HEREBY DISCLAIMS ANY DIRECT, SPECIAL, INDIRECT, INCIDENTAL, EXEMPLARY OR CONSEQUENTIAL DAMAGES OR DELAYS, INCLUDING, BUT NOT LIMITED TO, DAMAGES FOR LOSS OF PROFITS OR INCOME, LOSS OF USE, LOSS OF DATA, DOWNTIME, COVER AND EMPLOYEE OR INDEPENDENT CONTRACTOR WAGES, PAYMENTS AND BENEFITS. THIS DISCLAIMER SHALL SURVIVE ANY FAILURE OR ASSERTED FAILURE OF THE ESSENTIAL PURPOSE OF THIS LIMITED WARRANTY OR ITS REMEDIES SPECIFIED HEREIN. WARRANTY DISCLAIMER THIS WARRANTY IS MIDMARK'S ONLY WARRANTY AND IS IN LIEU OF ALL OTHER WARRANTIES, EXPRESS OR IMPLIED. MIDMARK MAKES NO IMPLIED

WARRANTIES OF ANY KIND INCLUDING ANY IMPLIED WARRANTIES OF MERCHANTABILITY OR FITNESS FOR A PARTICULAR PURPOSE. THIS WARRANTY IS LIMITED TO THE REPAIR OR REPLACEMENT OF DEFECTIVE PARTS.

STATUTE OF LIMITATIONS No action may be brought against Midmark for breach of this limited warranty, an implied warranty, if any, or for any other claim arising out of or relating to the products, more than ninety (90) days following expiration of the limited warranty period.

NO AUTHORIZATION No person or firm is authorized to create or approve for Midmark any other obligation or liability in connection with the products.

General Information

Intended Use

This product is intended to control patient positioning while providing better patient access by eliminating the cord from the controller(s).

Calling for Service

If service is required, contact your Midmark dealer. To contact Midmark directly:

1-800-MIDMARK (1-800-643-6275)
Monday-Friday 8:00 am until 5:00 pm (EST)
www.midmark.com

Midmark Corporation
60 Vista Drive
Versailles, OH 45380-0286
Phone: 937-526-3662
Fax: 937-526-5542
www.midmark.com



Because we care.



User's Guide

625 Wireless Controls

9A429



This guide outlines basic operation of the wireless hand / foot control and the associated base station. If service is required, contact your authorized Midmark dealer.

Dealer (name / phone):

Date of Purchase: _____

Compliance Information - continued...

IC Compliance Statement

Interference

"This device complies with Industry Canada license-exempt RSS standard(s). Operation is subject to the following two conditions: (1) this device may not cause interference, and (2) this device must accept any interference, including interference that may cause undesired operation of the device."

"Le présent appareil est conforme aux CNR d'Industrie Canada applicables aux appareils radio exempts de licence. L'exploitation est autorisée aux deux conditions suivantes: (1) l'appareil ne doit pas produire de brouillage, et (2) l'utilisateur de l'appareil doit accepter tout brouillage radioélectrique subi, même si le brouillage est susceptible d'en compromettre le fonctionnement."

Antennas

"Under Industry Canada regulations, this radio transmitter may only operate using an antenna of a type and maximum (or lesser) gain approved for the transmitter by Industry Canada. To reduce potential radio interference to other users, the antenna type and its gain should be so chosen that the equivalent isotropically radiated power (e.i.r.p.) is not more than that necessary for successful communication."

"Conformément à la réglementation d'Industrie Canada, le présent émetteur radio peut fonctionner avec une antenne d'un type et d'un gain maximal (ou inférieur) approuvé pour l'émetteur par Industrie Canada. Dans le but de réduire les risques de brouillage radioélectrique à l'intention des autres utilisateurs, il faut choisir le type d'antenne et son gain de sorte que la puissance isotrope rayonnée équivalente (p.i.r.e.) ne dépasse pas l'intensité nécessaire à l'établissement d'une communication satisfaisante."

Association Procedure

The wireless controller will only function with the chair it has been "associated" with. This prevents unwanted movement in locations with more than one chair.

Each wireless controller's association is preset at the factory. This procedure is only required in the event of a malfunction, if a new controller is purchased, or if you are attempting to use the controller with a chair other than the one it was originally associated with.

Association Procedure:

A) Disconnect power to the table for at least 3 seconds.

B*) Reconnect power, wait for the power up beep sequence from the table, then press & hold the **Stop & Home** buttons on the wireless controller until you hear three "beeps".

* Note: Step B must be performed within 10 seconds of the power up beep sequence from the table.

C) Check for proper operation of wireless controller.

D) If associating a hand **and** foot control, repeat procedure using the other wireless controller.

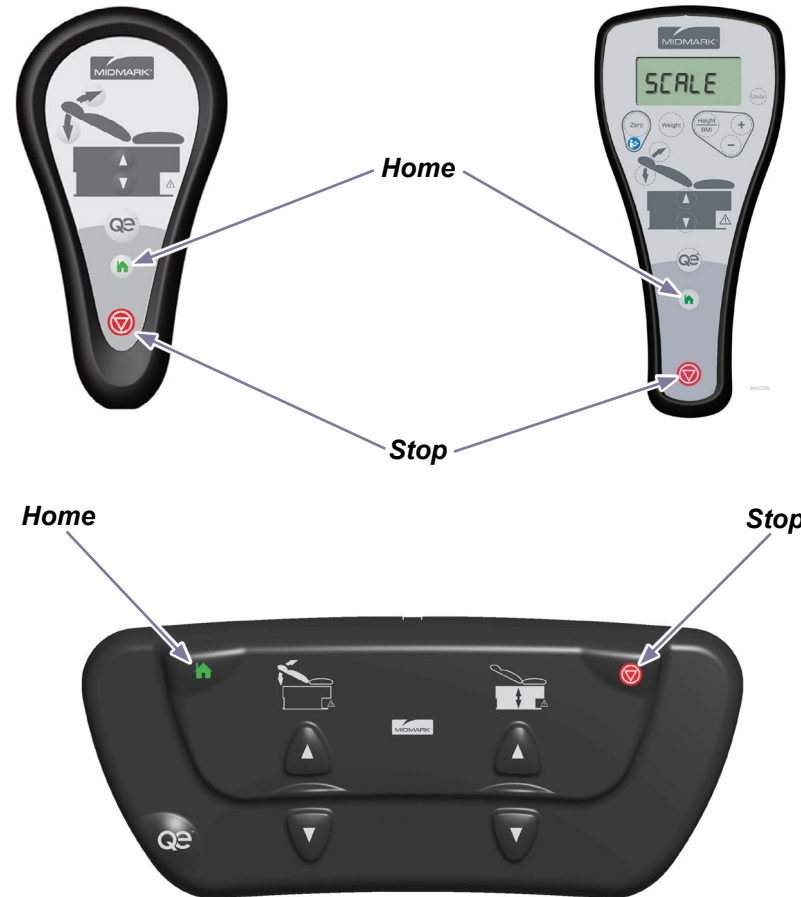

Specifications

Range of Operation..... 20 ft. (6 m) radius

Batteries:

Hand Control.....AA (qty. 2)

Foot Control.....AA (qty. 2)

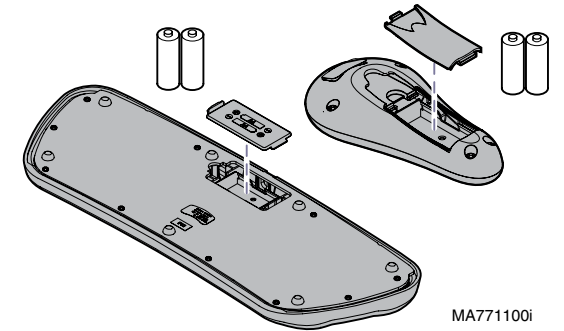

Troubleshooting

When any control button is pressed, that controller sounds a single "beep". (All functions operate)

Cause: Low battery

Solution: Replace batteries

When any control button is pressed, nothing happens. (No "beeps", no movement, etc.)

Cause: 1. Batteries completely dead
2. Wireless controller has lost "association" to chair

Solution: 1. Replace batteries
2. Perform **Association Procedure***

The wireless controllers will only function with the chair they have been "associated" with. This prevents unwanted movement in locations with more than one chair.

If further service is required, contact your authorized Midmark dealer.